

**COUNTY OF SAN MATEO
PLANNING AND BUILDING DEPARTMENT**

DATE: May 23, 2018

TO: Planning Commission

FROM: Planning Staff

SUBJECT: EXECUTIVE SUMMARY: Consideration of a Coastal Development Permit to repair a section of eroding road embankment located at Postmile 0.3 (Elliot Creek) and reconstruct a minor drainage system located at Postmile 0.6 (Finney Creek), both located on Highway 1, just north of the Santa Cruz County line, in the unincorporated Pescadero area of San Mateo County. This project is appealable to the California Coastal Commission.

County File Number: PLN 2018-00051 (CalTrans)

PROPOSAL

The California Department of Transportation (Caltrans) proposes to repair slip-outs caused by storm water runoff at two locations on State Route (SR) 1 in San Mateo County, just north of the Santa Cruz County line. Location 1 is located adjacent to southbound SR 1 at Postmile 0.3 near Elliot Creek, and Location 2 is located adjacent to northbound SR 1 at Postmile 0.6 near Finney Creek.

Work proposed at Location 1 (Elliot Creek) consists of: 1) placing 1,140 square feet of rock slope protection (RSP) on the coastal bluff west of Post Mile 0.3; 2) placing one foot of soil over the RSP (1,400 cubic feet) and revegetate disturbed soil; 3) installing two drain inlets and an asphalt dike along the road edge in the southbound direction; and 4) correcting a recurring sag point in the roadway caused by repeated settlement.

At Location 2 (Finney Creek), a non-functioning drainage system is causing surface water ponding on the shoulder of northbound SR 1. Sandbags have been placed at this location as a temporary measure to prevent any further erosion. The purpose of the work at this location is to upgrade the drainage system by: 1) capping the entrance of the existing down drain; 2) installing three drain inlets with 18" culverts connecting the inlets in the northbound direction; 3) reconstructing the asphalt (AC) dike; and 4) installing a down drain and rock pad at the discharge point.

RECOMMENDATION

Approve the Coastal Development Permit, County File Number PLN 2018-00051, by adopting the required findings and conditions of approval contained in Attachment A.

SUMMARY

Staff has completed a review of the project and all submitted documents and reports in order to determine the project's conformity to applicable LCP policies and Zoning regulations. Potential impacts to biological resources were identified during this review, and conditions of approval were included to reduce these potential impacts to a less than significant level.

The applicant wishes to conduct the proposed work to correct existing storm damage, prevent future erosion, maintain the integrity of the roadway, and enhance driver safety. The work proposed under this permit will be minor in scope and, as conditioned, will not create a significant impact upon the area's biotic resources.

MJS:aow – MJSCC0234_WAU.DOCX

**COUNTY OF SAN MATEO
PLANNING AND BUILDING DEPARTMENT**

DATE: May 23, 2018

TO: Planning Commission

FROM: Planning Staff

SUBJECT: Consideration of a Coastal Development Permit, pursuant to Section 6328.4 of the County Zoning Regulations, to repair a section of eroding road embankment located at Postmile 0.3 (Elliot Creek) and reconstruct a minor drainage system located at Postmile 0.6 (Finney Creek), both located on Highway 1, just north of the Santa Cruz County line, in the unincorporated Pescadero area of San Mateo County. This project is appealable to the California Coastal Commission.

County File Number: PLN 2018-00051 (CalTrans)

PROPOSAL

The California Department of Transportation (CalTrans) proposes to repair slip-outs caused by storm water runoff at two locations on State Route (SR) 1 in San Mateo County, just north of the Santa Cruz County line. Location 1 is located adjacent to southbound SR 1 at Postmile 0.3 near Elliot Creek, and Location 2 is located adjacent to northbound SR 1 at Postmile 0.6 near Finney Creek.

Work proposed at Location 1 (Elliot Creek) consists of: 1) placing 1,140 square feet of rock slope protection (RSP) on the coastal bluff west of Post Mile 0.3; 2) placing one foot of soil over the RSP (1,400 cubic feet) and revegetate disturbed soil; 3) installing two drain inlets and an asphalt dike along the road edge in the southbound direction; and 4) correcting a recurring sag point in the roadway caused by repeated settlement.

At Location 2 (Finney Creek), a non-functioning drainage system is causing surface water ponding on the shoulder of northbound SR 1. Sandbags have been placed at this location as a temporary measure to prevent any further erosion. The purpose of the work at this location is to upgrade the drainage system by: 1) capping the entrance of the existing down drain; 2) installing three drain inlets with 18" culverts connecting the inlets in the northbound direction; 3) reconstructing the asphalt (AC) dike; and 4) installing a down drain and rock pad at the discharge point.

RECOMMENDATION

Approve the Coastal Development Permit, County File Number PLN 2018-00051, by adopting the required findings and conditions of approval contained in Attachment A.

BACKGROUND

Report Prepared By: Michael Schaller, Senior Planner, 650/363-1849

Applicant: CalTrans (Stefan Galvez)

Owner: State of California

Location: State Route 1 at Postmile 0.3 and Postmile 0.6 (adjacent to 640 Cabrillo Hwy., Pescadero)

APN: Pubic Right of Way (adjacent to 089-230-420)

Existing Zoning: Planned Agricultural District (PAD)
General Plan Designation: Agriculture - Rural

Williamson Act: N/A - Public Right of Way

Existing Land Use: State Highway and adjacent open space areas.

Flood Zone: Both locations: Zone A (Areas subject to inundation by the 100-year flood, No Base Flood Elevations determined), FEMA Panel Number 06081C0506F, effective date October 16, 2012.

Environmental Evaluation: CalTrans has assumed the role of lead agency. As such, they have filed a Categorical Exemption under Section 15301 of the California Environmental Quality Act (see Attachment F).

Setting: In the case of Location 1 (Elliot Creek), the land cover, around and associated with the project footprint, consists primarily of non-native annual grass species immediately adjacent to the roadway and Coastal Bluff Scrub around the perimeter of the area where the road bank will be repaired. Elliot Creek flows through a culvert under Cabrillo Highway. Around the outlet of the culvert and the area of bank repair, the vegetation consists of species common to riparian corridors such as California blackberry and poison oak. Two Monterey Cypress trees are within this portion of the project footprint and will be removed as part of the bank repair. No wetlands were identified within the project footprint. With regards to sensitive species, the CalTrans biological report identifies three species with a moderate potential to occur within the project site: the California red-legged frog (CRLF), San Francisco garter snake (SFGS), and San Francisco dusky footed woodrat (SFDFW). Vegetation and sensitive species potential are similar at Location 2 (Finney Creek) just to the north.

DISCUSSION

A. KEY ISSUES

1. Conformance with the County General Plan

The County's Local Coastal Program (LCP) is a subset of, and consistent with, the County General Plan. The following analysis of the project's conformance to the LCP thereby also addresses the project's consistency with the County's General Plan.

2. Conformance with the Local Coastal Program

A Coastal Development Permit is required pursuant to San Mateo County Local Coastal Program Policy 2.1, which mandates compliance with the California Coastal Act for any government agency wishing to undertake development in the Coastal Zone. While the work proposed for this Coastal Development Permit is relatively minor in scope, it does meet the definition of development contained in Policy 1.2 (*Definition of Development* - "construction, reconstruction, demolition, or alteration of the size of any structure, including any facility of any private, public, or municipal utility"). Section 6328.5 of the County Zoning Regulations outlines the allowed exemptions to the requirements for a Coastal Development Permit. Public Works projects (which includes both the County Department of Public Works and CalTrans), regardless of their size, are not included within the listed exemptions. Thus, a Coastal Development Permit (CDP) is required for this project.

Summarized below are the following sections of the LCP that are relevant to this project:

a. Public Works Component

Policy 2.42 - Capacity Limits. This policy limits the expansion of roadway capacity which does not exceed the needed amount to accommodate peak traffic and maintaining Highway 1 as a scenic two-lane road outside of the Urban Midcoast area. At the Elliot Creek location, the project will repair a section of eroding bluff by placing approximately 1,500 square feet of rock slope protection (RSP) on the bluff and then placing approximately 55 cubic yards of soil over the RSP. The disturbed area will then be hydroseeded to encourage plant growth and soil stabilization. Additionally, a recurring sag point in the roadway, caused by repeated settlement, will be repaired.

At the Finney Creek location, the proposed work will fix existing drainage problems that create hazardous driving conditions as well as presenting problems for bicyclists using this portion of Highway 1.

The purpose of the proposed work is to maintain the integrity of the roadway, and improve driver safety. These improvements will not increase the traffic capacity of Highway 1 in this location or in the Pescadero area of the County. The project is not growth-inducing and is not anticipated to result in an increase in vehicular traffic. Two-way and one-way traffic control will be necessary for the construction of the project. These impacts will be temporary and will only last during the 60 days proposed for construction of the project.

b. Sensitive Habitats Component

As outlined above in the setting section, both project sites could support sensitive habitat as defined under Policy 7.1 (*Definition of Sensitive Habitats*). Sensitive habitat areas include all perennial and intermittent streams and their tributaries. As discussed above under the project proposal section, both project sites involve work within the limits of the riparian corridors associated with the two creeks. In addition, the work sites have the potential to support special status wildlife species (CRLF, SFGS and SFDFW).

Policy 7.3 - *Protection of Sensitive Habitats*. This policy prohibits any land use or development which would have a significant adverse impact on sensitive habitat areas. Additionally, development in areas adjacent to sensitive habitats shall be sited and designed to prevent impacts that could significantly degrade the sensitive habitats. All uses shall be compatible with the maintenance of biologic productivity of the habitats. The potential for the federally listed CRLF, SFGS, and SFDFW to occur at each project site, potential effects of the proposed project on these species, and avoidance and minimization measures for each species are discussed below. The biological assessment submitted by the applicant demonstrates that the proposed project will have no effect on any other listed wildlife species.

Both project sites are within the final designated Critical Habitat for the California red-legged frog (CRLF). A riparian corridor running perpendicular to SR 1 may provide upland habitat for CRLF, and it is within the central coast recovery unit for the species. Elliot Creek itself runs 20 feet underneath Highway 1 in a culvert, making the associated riparian area atypical in vegetation makeup. The coastal scrub habitat within the Elliot Creek project footprint may provide upland dispersal habitat for CRLF. While small mammal burrows that may attract CRLF appear to be lacking within the coastal scrub, dense vegetation

(including California blackberry and poison oak) provides refuge and potential opportunities for foraging.

The coastal scrub habitat within the Elliot Creek project footprint is primarily un-vegetated and contains few features that would attract foraging or estivating CRLF. Any individuals in the Project footprint would likely be transient and/or dispersing and unlikely to use the Project footprint for any extended length of time. No CRLFs were observed onsite during reconnaissance site visits or focused botanical surveys. The closest documented sighting of CRLF is one mile to the north of the project site, in a pond on the same side of Highway 1 as the project site. Based upon the relative proximity of primary habitat to the north, the applicant's biologist has determined that there is a moderate potential for the CRLF to be present at either project site at the time of construction. To mitigate any potential impacts to the frog, the biological report recommends a number of measures, which have been incorporated as conditions of approval (Nos. 15 - 19) in Attachment A.

No SFGS were detected during the habitat assessment and site reconnaissance for this project; however, this species has been documented previously at several locations within a two mile radius of the project site. Coastal scrub habitat within the Project footprint provides suitable upland dispersal/overwintering habitat for SFGS because of the proximity to the drainage corridor (Elliot Creek); however, it lacks the open grassy characteristics and small mammal burrows which SFGS may prefer. Neither Elliot Creek nor Finney Creek present suitable habitat for SFGS breeding (at the project locations) because of their fast pace, lack of ponds, and lack of prey items. While the chances of SFGS occupying either site during construction are small, there is nevertheless a chance, therefore, the applicant is proposing to implement the avoidance and mitigation measures incorporated as Conditions of Approval Nos. 15 - 19.

No San Francisco dusky-footed woodrats or dens were identified within the project footprint during field surveys for this project. The Monterey pine riparian forest along Elliot Creek within the project footprint may provide suitable habitat for this species. Dense understory forest habitat is present in this area. However, this potential habitat occurs adjacent to a heavily traveled roadway (Highway 1) with persistent noise disturbance. Therefore, San Francisco dusky-footed woodrat could occur at either project location, albeit habitat suitability is poor. However, as with the CRLF and SFGS, even though the likelihood of the woodrat being present at either project site is small, there is still a chance. Therefore, the applicant is proposing to implement, at both locations, standard

monitoring and avoidance measures (incorporated as Conditions of Approval Nos. 20 and 21).

In the case of the Elliot Creek site, the project biologist has determined that the removal of the vegetation within approximately 0.034 acres of coastal bluff scrub for the RSP would constitute a minor loss of potential habitat for SFDFW. Because understory vegetation removal would occur along or adjacent to a steep roadway embankment that is subject to regular disturbance from a highly traveled roadway, the loss of this potential habitat is not likely to adversely affect the local population. This area of disturbance will be revegetated at the end of the project to both stabilize the site and eventually provide replacement habitat.

No wetlands were found within either project footprint during surveys conducted for this project. One culverted water feature was identified in the Elliot Creek footprint that is classified as waters of the United States: Elliot Creek (80 linear feet), which is a tributary to the Pacific Ocean. This section of Elliot Creek is culverted and will be avoided; all work will be done above the banks of Elliot Creek.

Policy 7.11 - Establishment of Buffer Zones (for Riparian Corridors). This policy establishes a buffer zone of 50 feet as measured from the limit of riparian vegetation for all riparian corridors. Elliot Creek passes under and through the project footprint via an existing concrete box culvert that emerges out of the road embankment approximately 20 feet below the foot of the proposed RSP.

Permitted uses within the buffer zone (Policy 7.12) include repair or maintenance of roadways or road crossings. The purpose of this project is to address localized erosion and land sliding of the road embankment in order to prevent loss of the roadway.

Policy 7.13 – Performance Standards in Buffer Zones (for Riparian Corridors). This policy requires development permitted in buffer zones to minimize removal of vegetation; and use only adapted native or non-invasive exotic plant species when replanting. No work is proposed within or immediately adjacent to the riparian corridor which is completely contained within the box culvert as it passes through the embankment and exits below the area of work. What vegetation removal that will occur is limited to the immediate area of work, approximately 1,500 sq. ft. in area. The applicant has proposed revegetating all disturbed areas with native grass and shrub species.

c. Visual Resources Component

Policy 8.5 - *Location of Development*. This policy requires that development be located on a portion of a parcel where it is least visible from State and County Scenic Roads. This stretch of Highway 1 is designated as a State Scenic Road/Corridor. The embankment repair (at Elliot Creek) will be below road level and, once the revegetation has taken, will not be visible to motorists traveling on Highway 1.

The proposed drainage improvement work at Finney Creek is minor in scope and will not be visible from the roadway upon completion of construction.

d. Shoreline Access Component

Policy 10.1 (*Permit Conditions for Shoreline Access*). This policy requires some provision for shoreline access as a condition of granting development permits for any public or private development between the sea and the nearest road. This policy reflects the requirements of Chapter 3, Article 2 (*Public Access*) of the Coastal Act. Policy 10.10 - *Fragile Resources (Sensitive Habitats)* also states "Open the access in sensitive habitats or their buffer zones for public use **only** when development standards and management practices are adequate to protect the resources". Establishing a new access at the Elliot Creek location is not feasible because of the steep slopes, lack of lateral access and sensitive habitat. There is approximately two feet between the edge of the travel way for Highway 1 and the adjacent bluff edge. Given the high speed cars are travelling on the highway, more space would be needed to provide adequate safety for pedestrians traveling laterally along the top of the bluff. Providing vertical access down the face of the bluff is problematic given the erodibility of the underlying soil and the presence of riparian habitat (associated with the free flowing portion of Elliot Creek) and the potential for CRLF on the site. For these reasons, Staff does not believe that requiring access at this location is appropriate. It should be noted that public access to the shoreline is available approximately ¼ mile to the north.

The proposed work at Finney Creek is on the easterly (inland) side of Highway 1 and is not subject to the provisions of Policy 10.1.

3. Compliance with PAD Zoning Regulations

The Coastal Act of 1976 requires that the County's Local Coastal Program (LCP) include a Land Use Plan that is consistent with the policies of the

Coastal Act, and an Implementation Program including zoning ordinances, zoning district maps, and other actions necessary to carry out the Land Use Plan. To that end, the County's Zoning Regulations are an important component of the LCP, and all public and private projects must comply with applicable zoning requirements.

Section 6352 - *Uses Permitted*. The U.S. Department of Agriculture Soil Conservation Service has designated the soils within the project footprint at Elliot Creek as Class II (Prime Soils). There are no prime soils located within the Finney Creek project footprint. In both instances, any potential agricultural use (within the project footprints) was previously extinguished by the construction of Highway 1 during the 1950's.

Existing public infrastructure, such as Highway 1, is not listed as permitted uses on prime soil lands. However, non-residential development customarily considered accessory to agricultural uses are permitted on prime soils. Highway 1 is the primary north-south transportation artery for the San Mateo Coastside. Without this road, access to numerous agricultural parcels would not be possible. The proposed repair work is necessary to ensure continued access to these parcels.

4. Compliance with County Grading Ordinance

To repair the failed bank slip-out at Elliot Creek, the applicant is proposing to remove approximately 280 cubic yards of soil. The bank will then be reconstructed with rock slope protection with approximately 55 cubic yards of soil placed on top of that to address visual impacts as well as provide a soil medium to allow for successful revegetation of the work area. While this proposed work is near the box culvert through which the creek passes, the work is actually 20 feet up-slope from the outfall of the culvert and will not directly impact the creek's "channel". Only minimal grading is proposed at the Finney Creek location to accommodate the proposed drainage improvements.

Because the applicant is the State, issuance of a grading permit is not required. However, the project must be consistent with the County's Grading Ordinance, which is also a component of the LCP's Implementation Program. The discussion below demonstrates compliance with the County's Grading Ordinance:

a. **That the project will not have a significant adverse effect on the environment.**

The proposed grading at Elliot Creek is necessary to implement the project. Erosion control measures will be implemented during construction to reduce potential off site sedimentation and water

quality impacts. The bank reconstruction has been designed to minimize long-term impacts to drainage and adjacent areas. Measures to protect potential biotic resources within the footprint of the project have also been included as conditions of approval. Therefore, staff has determined that the project, as proposed and conditioned, will not have a significant adverse impact on the environment.

- b. That the project conforms to the criteria of Chapter 8, Division VII, San Mateo County Ordinance Code, including the standards referenced in Section 8605.**

The work at both project sites, as proposed and conditioned, conforms to standards in the Grading Ordinance, including those relative to erosion and sediment control, and the timing of grading activity. Conditions of approval have been included in Attachment A to ensure compliance with the County's Grading Ordinance.

- c. That the project is consistent with the General Plan.**

The General Plan land use designation for both locations is Agriculture - Rural. As proposed and conditioned, both projects comply with applicable General Plan and Local Coastal Plan policies, as discussed in Section A.1 of this report.

B. ENVIRONMENTAL REVIEW

CalTrans has assumed the role of lead agency. As such, they have filed a Categorical Exemption under Section 15301 (*Repair or minor alteration of existing public or private structures, facilities, or topographical features, involving negligible or no expansion of use*) of the California Environmental Quality Act Guidelines.

C. REVIEWING AGENCIES

California Coastal Commission

On April 20, 2018 the County received comments from the California Coastal Commission (Attachment H). The applicant has provided the following responses and clarifications to the Coastal Commission letter.

Coastal Commission Comment: The applicant's Biology Impact Form included with the project referral does not state whether or not these creeks are perennial or intermittent streams. The report, however, does indicate that "semi-riparian" habitat occurs in the vicinity of the project. The biological form states that wetland field surveys were performed in January and July 2017. The form, however, does not provide any additional information regarding survey results and the proposed

project's potential impact to wetlands or the adjacent streams. We recommend that the County require the applicant provide information regarding potential wetland and stream impacts. The County analysis should consider these potential impacts and require that the applicant avoid, minimize, and mitigate potential wetland impacts.

CalTrans Response: Finney Creek is [a] perennial [stream], and Elliot Creek is [a] seasonally flooded [stream]. Both creeks support a semi-riparian plant community and upland habitat for California red-legged frog (CRLF) and San Francisco garter snake (SFGS). Both creeks are culverted under the roadway and will be avoided during construction. Potential impacts to wetlands and streams can be found in Chapter 4.2.1 of the Natural Environment Study (NES). These potential impacts will be avoided through the use of standard avoidance and minimization measures. The attached wetland delineation memos written for Elliot Creek and Finney Creek explain why these two streams will not be impacted. It should be noted that the delineation memo for Elliot Creek was written based on a larger project footprint than the project's final design and, therefore, the area of impact described in the memo, such as the area to be covered by Rock Slope Protection (RSP), is larger than what will actually be constructed.

The project sites at Elliot Creek and Finney Creek do not meet the definition of a wetland as defined by San Mateo County's LCP Policy 7.14 - *Definition of Wetlands* (there are no hydric soils, water, or plants within the footprint of these two proposed projects). Therefore, San Mateo County's LCP Policies 7.16 - *Permitted Uses in Wetlands*, and 7.17 - *Performance Standards*, do not apply to this project because no work will be performed within wetlands.

County Staff's Analysis: Based upon the additional information submitted by the applicant, County staff concurs that neither project location contains "wetlands" as defined by Policy 7.14 of the LCP. Both sites do, of course, contain riparian streams as discussed above.

Coastal Commission Comment: The removal of vegetation [at Elliot Creek] will result in loss of potential habitat for CRLF and SFGS in the form of direct permanent loss (0.027 acre) of upland habitat. There will also be temporary direct effects to ground cover. Upland habitat for CRLF and SFGS does have value in support of these two species. We recommend that all permanent loss of suitable upland habitat for CRLF and SFGS should be mitigated at a minimum ratio of 2:1. The County should also require that the applicant provide mitigation for all temporary impacts associated with the construction activities for the project.

CalTrans Response: Regarding the CCC's comment "we recommend that all permanent loss of suitable upland habitat for CRLF and SFGS should be mitigated at a minimum ratio of 2:1", [this] is in reference to the project elements which will be constructed on potential upland habitat and refers to the rock slope

protection (RSP), downdrains, rock dissipater pad, and concrete dikes. The 0.027 acres of RSP at Elliot Creek will be covered in native soil up to one-foot thick, hydroseeded with a native mixture, and covered with the woody material that was removed at the start of construction. Areas around the small rock dissipater pad at Finney Creek and all disturbed soil will be hydroseeded and covered with woody material that is to be removed at the start of construction (see pages 3, 5, and 21 of the USFWS Biological Opinion, January 2018). This soil placement and revegetation is part of the project description, therefore, a separate mitigation was not planned. The Biological Opinion states that this method will allow for natural vegetation to grow in less than one year of initial disturbance (page 21). In regard to CRLF critical habitat, the Biological Opinion also states that the disturbed upland habitat is expected to regain baseline values within 5 years due to capping RSP with native soil and revegetation measures.

County Staff's Analysis: Staff concurs with the applicant's contention that a separate mitigation is not necessary. The loss of upland habitat at both locations will be modest and relatively short in duration. The applicant's project design for both locations includes revegetating disturbed areas with native plant species, which will improve the overall habitat at each location since non-native plant species will be removed.

CalTrans Response: Regarding the CCC's comment "the County should also require that the applicant provide mitigation for all temporary impacts associated with the construction activities for the project", the dominant plant species currently found at the Elliot Creek project site are two native plants: poison oak and California blackberry. Multiple non-native or invasive herbaceous plants, such as Italian thistle, bristly ox-tongue, wild radish, garden vetch, and wild oat are also present. The Biological Impact Form references indirect effects on habitat that will include a lack of natural ground cover and that the amount of time these impacts would be felt will be short. It should be clarified that the "lack of natural ground cover" will be due to the removal of existing vegetation in order to place the RSP. This will then be covered by soil, up to one foot thick, which will then be hydroseeded with a native seed mixture and will have large woody debris placed on top (the large woody debris will be the exact same that will be removed before construction). It will take less than one year from initial soil disturbance for the hydroseed to grow in.

County Staff's Analysis: Staff concurs that no additional mitigation for the temporary loss of vegetation is required. The proposed replanting will sufficiently mitigate the temporary site disturbance required to implement the project.

Coastal Commission Comment: The proposed project site is located within the Cabrillo Highway State Scenic Corridor. The applicant's scenic resource evaluation states that concrete that is visible along the slopes shall be stained to blend with the coastal landscape. The County should require the applicant to provide specific information regarding the material proposed to be used for

staining the concrete including what will be used, how it will be applied and maintained over time, what Best Management Practices and measures will be utilized to effectively prevent adverse impacts to the natural environment, including the adjacent creeks and coastal water.

CalTrans Response: The comment from the Coastal Commission references the Visual Impact Assessment and the recommendation that concrete that would be visible along the slopes should be stained to blend with the coastal landscape. That recommendation was included by Caltrans' Landscape Architecture unit to maintain visual resource quality along a Scenic Highway corridor. However, the project design does not include any exposed concrete that will be readily visible. As noted above, the RSP will be buried under at least one foot of topsoil and hydroseeded, which will mitigate any visual impacts from the placement of the RSP.

County Staff's Analysis: Based upon the plans submitted by the applicant as well as the written description provided in the various submitted documents, there does not appear to be any exposed concrete as part of either proposed project. The only visible objects/structures that motorists will see (for either project) will be standard size drop inlet grates (which are flush mounted within the existing pavement) and 1.5 foot tall asphalt dikes along the edge of the highway. Both of these objects/structures are very common on public roads throughout San Mateo County.

Coastal Commission Comment: The proposed project site is in the vicinity of the Año Nuevo State Natural Preserve and to the south of Pigeon Point Lighthouse, which are destination points for travelers along Highway 1. This proposed project could temporarily generate additional traffic in the area during construction. The County analysis should evaluate potential traffic impacts during construction and the effectiveness of the applicant's plan for managing traffic.

CalTrans Response: Although on some portions of Highway 1 the current traffic volumes do exceed road capacity, they do not at either project location. Traffic is free flowing in the vicinity of the project. Peak period traffic volumes do not exceed capacity. The project will temporarily cause traffic delays during construction as described below:

Location 1 (Elliot Creek): A one-way-reversing signal traffic-control system will be implemented. Traffic will be stopped in one direction for periods not to exceed 5 minutes. This traffic control is proposed to be implemented full time for approximately 4 weeks.

Location 2 (Finney Creek): No lane closure is proposed. No traffic delays are anticipated.

The project will not increase highway capacity nor widen the roadway.

County Staff's Analysis: Staff concurs with the applicant's assessment. The level of traffic congestion on this part of Highway 1 is negligible. While the one-way traffic signal at Elliot Creek will pose an inconvenience during its approximately four week duration, there are no practical alternatives. There is no alternate route along this stretch of the San Mateo coastline to funnel traffic onto. The lack of an alternative route reinforces the need for the project (at Elliot Creek) in order to prevent a catastrophic failure of the roadway.

ATTACHMENTS

- A. Recommended Findings and Conditions of Approval
- B. Location Map
- C. Project Plans - Elliot Creek
- D. Project Plans - Finney Creek
- E. Natural Environment Study - Elliot Creek Storm Damage Repair Project (prepared by CalTrans)
- F. CalTrans' adopted Categorical Exemption
- G. U.S. Fish and Wildlife Service Biological Opinion for the Elliot and Finney Creek Repair project.
- H. California Coastal Commission referral letter (dated April 20, 2018)
- I. CalTrans' Wetland Delineation Memos

MJS:aow – MJSCC0235_WAU.DOCX

County of San Mateo
Planning and Building Department

RECOMMENDED FINDINGS AND CONDITIONS OF APPROVAL

Permit or Project File Number: PLN 2018-00051

Hearing Date: May 23, 2018

Prepared By: Michael Schaller
Senior Planner

For Adoption By: Planning Commission

RECOMMENDED FINDINGS

Regarding the Environmental Review, Find:

1. That this project is categorically exempt pursuant to Section 15301 of the California Environmental Quality Act Guidelines, relating to the repair or minor alteration of existing public or private structures, facilities, or topographical features, involving negligible or no expansion of use.

Regarding the Coastal Development Permit, Find:

2. That the project, as described in the application and accompanying materials required by Zoning Regulations Section 6328.7 and as conditioned in accordance with Section 6328.14, conforms with the plans, policies, requirements and standards of the San Mateo County Local Coastal Program with regards to the protection of biotic and visual resources.
3. That the project conforms to the specific findings required by policies of the San Mateo County Local Coastal Program as discussed in Section A(2) of this Staff Report. Protection measures will be implemented to prevent any impact to biological resources, including San Francisco garter snake, California red-legged frog, and San Francisco dusky-footed woodrat.
4. That where the project is located between the nearest public road and the sea, or the shoreline of Pescadero Marsh, the project is in conformity with the public access and public recreation policies of Chapter 3 of the Coastal Act of 1976 (commencing with Section 30200 of the Public Resources Code). The project site is located between SR-1 and the sea, to the south of Año Nuevo State Park. There is no current or historic public access at this location due to the steep nature of the adjacent bluff and close proximity of the travel way to the bluff edge. Completion of the project will not change this situation nor will it inhibit existing public access at other nearby locations.

RECOMMENDED CONDITIONS OF APPROVAL

Current Planning Section

1. The approval applies only to the proposal as described in this report and materials submitted for review and approval by the Planning Commission on May 23, 2018. The Community Development Director may approve minor revisions or modifications to the project if they are found to be consistent with the intent of and in substantial conformance with this approval.

CalTrans General Avoidance and Minimization Measures

2. **Seasonal Avoidance.** To the extent practicable, construction will not occur during the wet season. Except for limited vegetation clearing (necessary to minimize impacts to nesting birds), work will be limited to the period from June 1 to October 31 to avoid the period when SFGS may be overwintering in uplands and CRLF are most active.
3. **A USFWS-Approved Biological Monitor.** The names and qualifications of proposed biological monitor(s) will be submitted to the USFWS for approval prior to the start of construction. Through communication with the resident engineer, the USFWS-approved biological monitor will be onsite during all work that could reasonably result in take of CRLF, SFGS, or marbled murrelet. The USFWS-approved biological monitor will have the authority to stop work that may result in the unauthorized take of special-status species.
4. **Worker Environmental Awareness Training.** Before beginning construction activities, a qualified biologist will conduct an education program for all Project construction personnel. At a minimum, the training will include a description of CRLF, SFGS, marbled murrelet, and migratory birds and their habitats; a discussion of the potential occurrence of these species within the Project footprint; an explanation of the status of these species and protection under Federal Endangered Species Act and California Endangered Species Act; the description of measures to be implemented to conserve listed species and their habitats as they relate to the work site; and the description of boundaries within which construction may occur. A fact sheet conveying this information will be prepared and distributed to the construction and Project personnel entering the Project footprint.
5. **Migratory Bird Treaty Act Protection.** To minimize and avoid take of migratory birds, their nests, and their young, Caltrans will conduct vegetation and tree trimming between September 30 and January 30 before Project construction. This work will be limited to vegetation and trees that are within the Project footprint. No grubbing or other ground-disturbing actions will occur during that period. Upon completion of vegetation and tree trimming, Caltrans will install stormwater and erosion control BMPs. A biological monitor with appropriate

construction and species experience will conduct nest and bird surveys and other wildlife surveys before and during tree cutting. All work will be conducted under a Regional Water Board-approved Water Pollution Control Plan or Stormwater Pollution Prevention Plan (SWPPP). Vegetation will be cleared only where necessary and will be cut above soil level. This will allow plants that reproduce vegetatively to re-sprout after construction. During the nesting season, pre-construction surveys for nesting birds, including the marbled murrelet, will be conducted by a qualified biologist no more than 72 hours prior to the start of construction activities. If work is to occur within 300 feet of active raptor nests or 50 feet of active passerine nests, a non-disturbance buffer will be established at a distance sufficient to minimize disturbance based on the nest location, topography, cover, the species' sensitivity to disturbance, and the intensity/type of potential disturbance. All clearing and grubbing of woody vegetation will be performed by hand or using light construction equipment, such as backhoes and excavators.

6. **Environmentally Sensitive Area Fencing.** Before starting construction, ESAs (defined as areas containing sensitive habitats adjacent to or within construction work areas for which physical disturbance is not allowed) will be clearly delineated using high-visibility orange fencing. The ESA fencing will remain in place throughout Project duration and will prevent construction equipment or personnel from entering sensitive habitat areas. The final Project plans will depict the locations where ESA fencing will be installed and how it will be assembled or constructed. The special provisions in the bid solicitation package will clearly describe acceptable fencing material and prohibited construction-related activities, vehicle operation, material and equipment storage, and other surface-disturbing activities within ESAs.
7. **Wildlife Exclusion Fencing.** Before starting construction, Wildlife Exclusion Fencing (WEF) will be installed along the Project footprint perimeter in the areas where wildlife could enter the Project site. Locations of the WEF will be determined in coordination with USFWS. The final Project plans will depict the locations where WEF fencing will be installed and how it will be assembled/constructed. The special provisions in the bid solicitation package will clearly describe acceptable WEF fencing material and proper WEF installation and maintenance. The WEF will remain in place throughout the Project duration, and will be regularly inspected for stranded animals and fully maintained.
8. **Implementation of Best Management Practices.** In accordance with Central Coast Regional Water Quality Control Board requirements, a SWPPP will be developed and erosion control BMPs implemented to minimize wind- or water related erosion. The Caltrans BMP Guidance Handbook provides guidance for the inclusion of provisions in all construction contracts to protect sensitive areas and prevent and minimize stormwater and non-stormwater discharges. At a minimum, protective measures will include:

- a. Disallowing discharging of pollutants from vehicle and equipment cleaning into storm drains or watercourses.
 - b. Keeping vehicle and equipment fueling and maintenance operations at least 50 feet away from watercourses, except at established commercial gas stations or an established vehicle maintenance facility.
 - c. Collecting and disposing of concrete wastes and water from curing operations in appropriate washouts, located at least 50 feet from watercourses.
 - d. Maintaining spill containment kits onsite at all times during construction operations and/or staging or fueling of equipment.
 - e. Using water trucks and dust palliatives to control dust in un-vegetated areas and covering of temporary stockpiles when weather conditions require.
 - f. Installing coir rolls or straw wattles along or at the base of slopes during construction to capture sediment.
 - g. Protecting graded areas from erosion using a combination of silt fences, fiber rolls along toes of slopes or along edges of designated staging areas, and erosion control netting (jute or coir) as appropriate on sloped areas.
 - h. Establishing permanent erosion control measures such as bio-filtration strips and swales to receive stormwater discharges from the highway or other impervious surfaces to the maximum extent practicable.
9. **Construction Site Management Practices.** The following site restrictions will be implemented to avoid or minimize potential impacts on listed species and their habitats:
- a. Enforcing a speed limit of 15 miles per hour in the Project footprint in unpaved and paved areas to reduce dust and excessive soil disturbance.
 - b. Locating construction access, staging, storage, and parking areas within the Project right-of-way outside any designated ESA or outside the right-of-way in areas environmentally cleared and permitted by the contractor. The following areas will be limited to the minimum necessary to construct the proposed Project: access routes, staging and storage areas, and contractor parking. Routes and boundaries of roadwork will be clearly marked before initiating construction or grading.
 - c. Certifying, to the maximum extent practicable, borrow material is non-toxic and weed free.

- d. Enclosing food and food-related trash items in sealed trash containers and removing them from the site at the end of each day.
 - e. Prohibiting pets from entering the Project footprint area during construction.
 - f. Prohibiting firearms within the Project site, except for those carried by authorized security personnel or local, state, or federal law enforcement officials.
 - g. Maintaining equipment to prevent the leakage of vehicle fluids such as gasoline, oils, or solvents and developing a Spill Response Plan. Storing hazardous materials, such as fuels, oils, and solvents, in sealable containers in a designated location that is at least 50 feet from aquatic habitat.
 - h. Servicing vehicles and construction equipment, including fueling, cleaning, and maintenance, at least 50 feet from aquatic habitat unless separated by topographic or drainage barrier.
10. **Avoidance of Entrapment.** To prevent inadvertent entrapment of animals during construction, excavated, steep-walled holes or trenches more than 1 foot deep will be covered at the close of each working day using plywood or similar materials, or provided with one or more escape ramps constructed of earth fill or wooden planks. Before such holes or trenches are filled they must be thoroughly inspected for trapped animals. Replacement pipes, culverts, or similar structures stored in the Project area overnight will be inspected before they are subsequently moved, capped, and/or buried.
11. **Vegetation Removal.** Vegetation that is within the cut-and-fill line or growing in locations where permanent structures will be placed (e.g., RSP.) will be cleared. Vegetation will be cleared only where necessary and will be cut above soil level except in areas that will be excavated. This will allow plants that reproduce vegetatively to re-sprout after construction. Clearing and grubbing of woody vegetation will occur by hand or using construction equipment such as mowers, backhoes, and excavators. If clearing and grubbing occurs between February 1 and September 30, a qualified biologist will survey for nesting birds within the areas to be disturbed, including a perimeter buffer of 50 feet for passerines and 300 feet for raptors, before clearing activities begin.
12. **Replant, Reseed, and Restore Disturbed Areas.** Caltrans will restore temporarily disturbed areas to the maximum extent practicable. Exposed slopes and bare ground will be reseeded with native grasses and shrubs to stabilize and prevent erosion. Where disturbance includes the removal of trees and woody shrubs, native species will be replanted, based on the local species composition.

13. **Reduce Spread of Invasive Species.** To reduce the spread of invasive, nonnative plant species and minimize the potential decrease of palatable vegetation for wildlife species, Caltrans will comply with Executive Order 13112. This order is provided to prevent the introduction of invasive species and provide for their control to minimize economic, ecological, and human-health impacts. In the event that noxious weeds are disturbed or removed during construction-related activities, the contractor will be required to contain the plant material associated with these noxious weeds and dispose of them in a manner that will not promote the spread of the species. The contractor will be responsible for obtaining all permits, licenses, and environmental clearances for properly disposing of materials. Areas subject to noxious weed removal or disturbance will be replanted with fast-growing native grasses or a native erosion-control seed mixture. Where seeding is not practical, the target areas within the Project footprint will be covered to the extent practicable with heavy black plastic solarization material until the end of the Project.
14. **Inclement Weather Restriction.** No work will occur during or within 24 hours following a rain event exceeding 0.2-inch as measured by the National Oceanic and Atmospheric Association National Weather Service for the Soquel, California, (SOQC1) base station.

California Red-legged Frog and San Francisco Garter Snake Specific Measures

As required under the Federal Endangered Species Act, Caltrans will implement reasonable and prudent measures to minimize and avoid take of CRLF. Because suitable habitat is present and CRLF have been documented within 1.5 miles of both project sites, Caltrans will implement both the general avoidance and minimization measures (listed above) and the following species-specific measures:

15. **Proper Use of Erosion Control Devices.** To prevent CRLF and SFGS from becoming entangled or trapped in erosion control materials, plastic monofilament netting (i.e., erosion control matting) or similar material will not be used within the Project footprint. Acceptable substitutes include coconut coir matting or tackifier hydroseeding compounds.
16. **Pre-Construction Surveys.** Pre-construction surveys for CRLF, SFGS, and marbled murrelet will be conducted by the USFWS-approved biological monitor no more than 20 calendar days prior to any initial ground disturbance and immediately prior to ground-disturbing activities (including vegetation removal) within upland habitat identified for the CRLF in the August 2017 Biological Assessment (Caltrans 2017). These efforts will consist of walking surveys of the Project footprint and, if possible, accessible adjacent areas within at least 50 feet of the Project footprint. The biological monitor will investigate potential cover sites when it is feasible and safe to do so. This includes thorough investigation of mammal burrows, rocky outcrops, appropriately sized soil cracks, tree cavities,

and debris. Native vertebrates found in the cover sites within the Project footprint will be documented and relocated to an adequate cover site in the vicinity.

17. **Biological Monitoring.** The USFWS-approved biological monitor will be present during construction activities where take of a listed species could occur. Through communication with the resident engineer or his/her designee, the USFWS approved biological monitor may stop work if deemed necessary for any reason to protect listed species and will advise the resident engineer or designee on how to proceed.
18. **Protocol for Species Observation.** The USFWS-approved biological monitor(s) will have the authority to halt work through coordination with the resident engineer in the event that a listed species is observed in the Project footprint. The resident engineer will keep construction activities suspended in any construction area where the biologist has determined that a potential take of the species could occur. Work will resume after observed listed individuals leave the site voluntarily, the biologist determines that no wildlife is being harassed or harmed by construction activities, or the wildlife is removed by the biologist to a release site using USFWS-approved handling techniques.
19. **Handling of Listed Species.** If a listed species is discovered, the resident engineer and USFWS-approved biological monitor will be immediately informed.
 - a. If a CRLF, SFGS, or marbled murrelet gains access to a construction zone, work will be halted immediately within 50 feet until the animal leaves the site or is captured and relocated by the USFWS-approved biological monitor.
 - b. The USFWS will be notified within one (1) working day if a CRLF, SFGS, or marbled murrelet is discovered within the construction site.
 - c. The captured CRLF, SFGS, or marbled murrelet will be released within appropriate habitat outside of the construction area but nearby the capture location. The release habitat will be determined by the USFWS-approved biological monitor.
 - d. The USFWS-approved biological monitor will take precautions to prevent introduction of amphibian diseases in accordance with the *Revised Guidance on Site Assessments and Field Surveys for the California Red-legged Frog* (USFWS 2005).

San Francisco Dusky-Footed Woodrat specific conditions

The following additional species-specific measures will be implemented to minimize potential adverse impacts on the San Francisco dusky-footed woodrat:

20. **Pre-construction Surveys for San Francisco Dusky-Footed Woodrat.** Before the start of construction, a qualified biologist will conduct a survey of the Project footprint and a 30-foot buffer beyond the Project footprint boundaries to determine the location of active and inactive woodrat dens. Any dens detected during the surveys will be recorded and mapped in relation to the construction disturbance footprint. In addition, the biologist will evaluate any signs of current woodrat activity, including the presence of fresh scat, freshly chewed vegetation, and the presence of cobwebs covering nest entrances. A 30-foot equipment exclusion buffer will be established around active and inactive dens that can be avoided; within such buffers, all vegetation will be retained and nests will remain undisturbed.

21. **Potential Trapping and Relocation.** If the Project cannot avoid impacts on an active den(s), then a trapping and relocation effort will be implemented. Relocation of trapped woodrats will occur as close as possible to the original den site. If suitable habitat is not available for relocation of woodrats in the Project vicinity, offsite locations will be identified. Trapping of woodrats will be conducted by a qualified biologist who has a current CDFW collection permit to trap and relocate the species. Such trapping will occur outside the breeding season, between September and December. Specific methods for trapping woodrats and relocation of individuals and their nest sites, including identification of suitable sites for relocation, will be developed in collaboration with CDFW.

MJS:aow – MJSCC0235_WAU.DOCX



County of San Mateo - Planning and Building Department

ATTACHMENT B

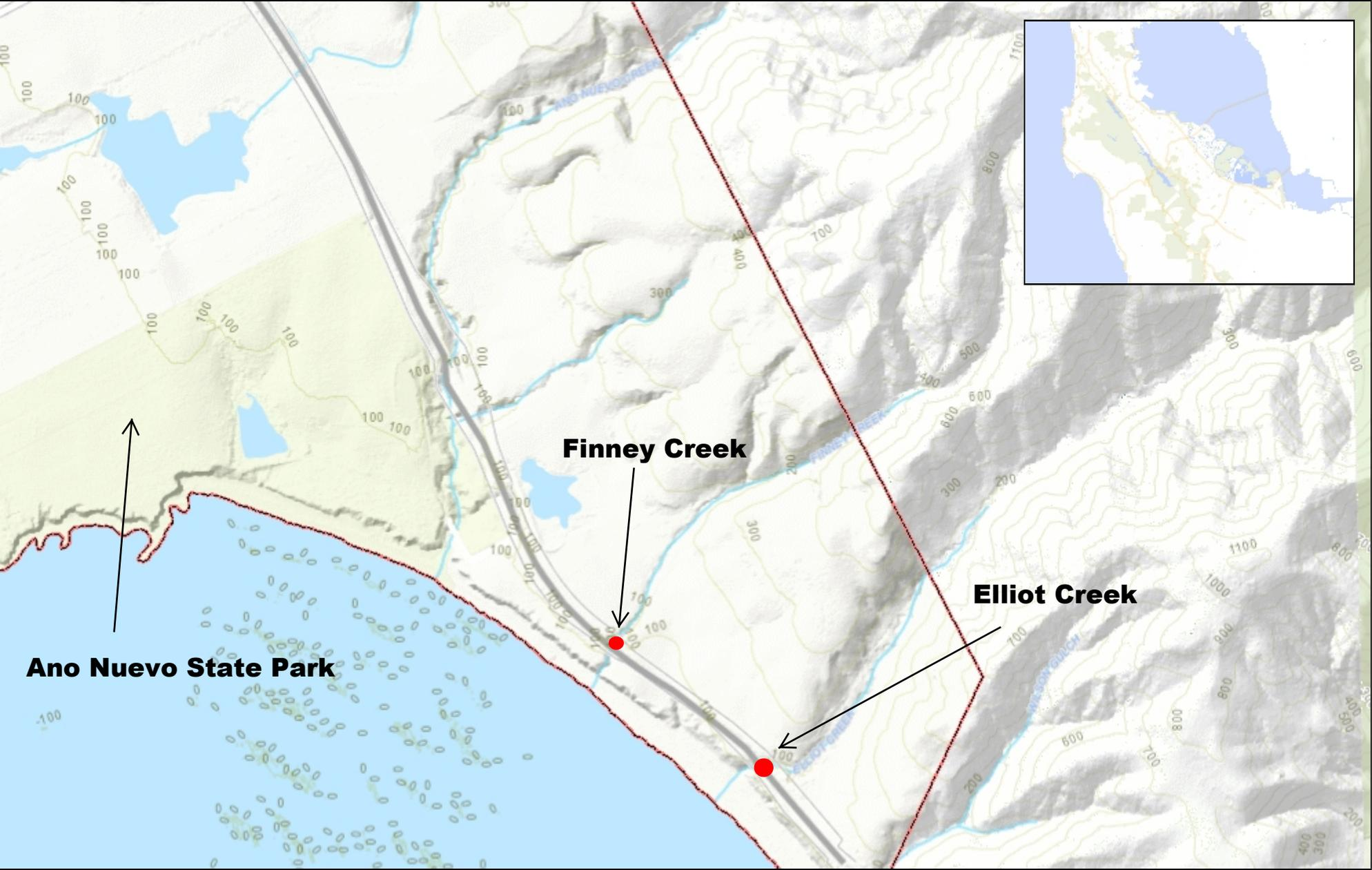

Ano Nuevo State Park

Finney Creek

Elliot Creek



County of San Mateo - Planning and Building Department

ATTACHMENT C

INDEX OF PLANS

- 1 TITLE SHEET AND LOCATION MAP
- 2 LAYOUT
- 3 CONSTRUCTION DETAILS
- 4 - 5 TEMPORARY WATER POLLUTION CONTROL PLAN AND DETAILS
- 6 - 8 DRAINAGE PLAN, PROFILES, DETAILS AND QUANTITIES
- 9 CONSTRUCTION AREA SIGNS
- 10 STAGE CONSTRUCTION PLAN AND DETAILS

STATE OF CALIFORNIA
DEPARTMENT OF TRANSPORTATION
PROJECT PLANS FOR CONSTRUCTION ON
STATE HIGHWAY
IN SAN MATEO COUNTY ABOUT
13 MILES SOUTH OF PESCADERO
AT ELLIOT CREEK

TO BE SUPPLEMENTED BY STANDARD PLANS DATED 2015

Dist	COUNTY	ROUTE	POST MILES TOTAL PROJECT	SHEET No.	TOTAL SHEETS
04	SM	1	0.3	1	





LOCATION MAP

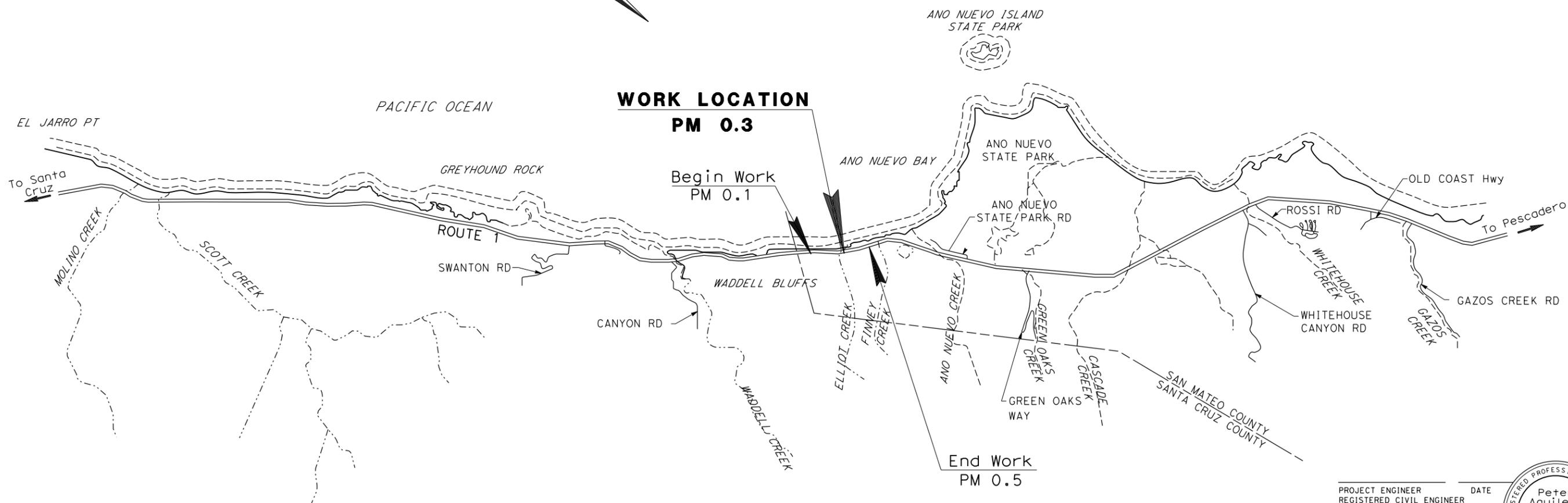
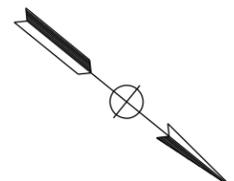

PROJECT MANAGER
 NIDAL TUOAN
 DESIGN MANAGER
 ARLISSA PANG

PROJECT ENGINEER REGISTERED CIVIL ENGINEER DATE



PLANS APPROVAL DATE
 THE STATE OF CALIFORNIA OR ITS OFFICERS OR AGENTS SHALL NOT BE RESPONSIBLE FOR THE ACCURACY OR COMPLETENESS OF SCANNED COPIES OF THIS PLAN SHEET.

CONTRACT No.	04-0J2104
PROJECT ID	0413000444

THE CONTRACTOR SHALL POSSESS THE CLASS (OR CLASSES) OF LICENSE AS SPECIFIED IN THE "NOTICE TO BIDDERS."

Dist	COUNTY	ROUTE	POST MILES TOTAL PROJECT	SHEET No.	TOTAL SHEETS
04	SM	1	0.3	3	
REGISTERED CIVIL ENGINEER					DATE
PETER AGUILERA					No. C55287
PLANS APPROVAL DATE					Exp. 12-31-18
CIVIL					STATE OF CALIFORNIA
<small>THE STATE OF CALIFORNIA OR ITS OFFICERS OR AGENTS SHALL NOT BE RESPONSIBLE FOR THE ACCURACY OR COMPLETENESS OF SCANNED COPIES OF THIS PLAN SHEET.</small>					

STATE OF CALIFORNIA - DEPARTMENT OF TRANSPORTATION	DESIGN
FUNCTIONAL SUPERVISOR	ARLISSA PANG
CALCULATED-DESIGNED BY	CHECKED BY
JOHN MOORE	PETER AGUILERA
REVISED BY	DATE
	REVISED

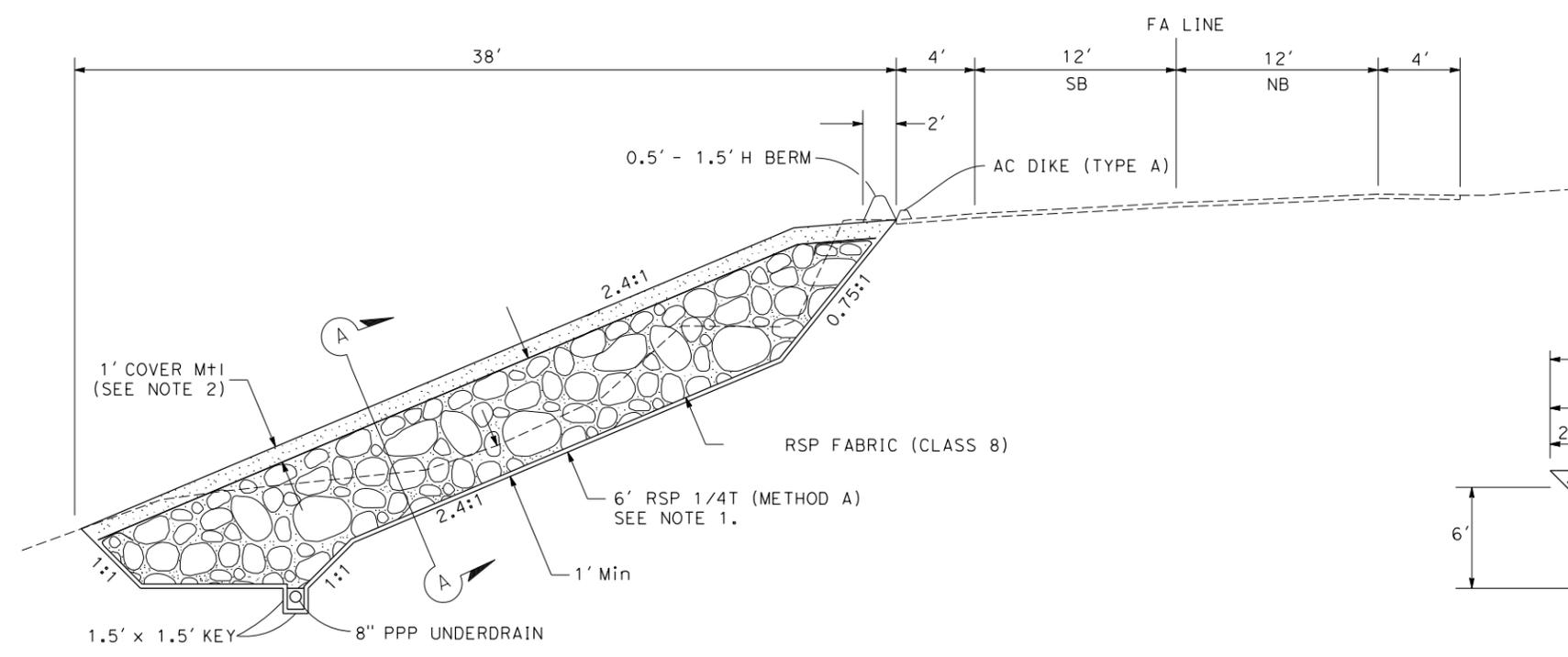

TYPICAL CROSS SECTION
Sta FA 17+65 TO 17+95

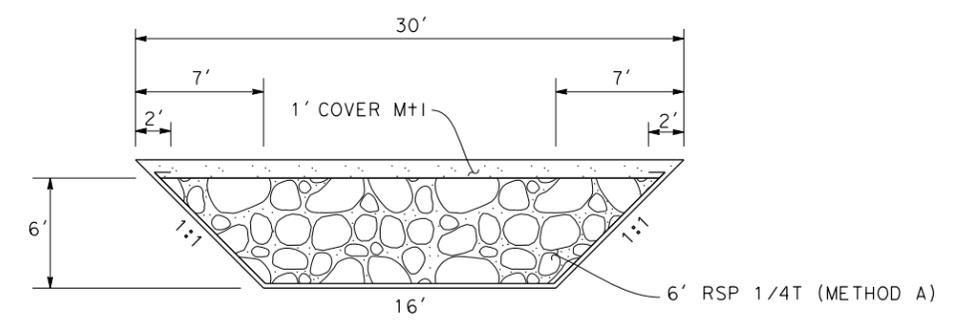

SECTION A-A

NOTES:

1. AFTER PLACING EACH LAYER OF RSP, FILL IN THE VOIDS WITH EXCAVATED NATIVE MATERIAL. FILL IN THE VOIDS TO A LEVEL LEAVING SUFFICIENT EXPOSED RSP FOR GOOD CONTACT WITH NEXT LAYER OF RSP.
2. SEE PLANSHEET EC-XX FOR COVER MATERIAL.

CONSTRUCTION DETAIL

NO SCALE

CD-1



STATE OF CALIFORNIA - DEPARTMENT OF TRANSPORTATION
Caltrans
 HYDRAULICS
 FUNCTIONAL SUPERVISOR
 DIXON LAU
 CALCULATED-DESIGNED BY
 CHECKED BY
 REVISED BY
 DATE REVISED

Dist	COUNTY	ROUTE	POST MILES TOTAL PROJECT	SHEET No.	TOTAL SHEETS
04	SM	1	0.3	7	
REGISTERED CIVIL ENGINEER			DATE		
PLANS APPROVAL DATE					
<small>THE STATE OF CALIFORNIA OR ITS OFFICERS OR AGENTS SHALL NOT BE RESPONSIBLE FOR THE ACCURACY OR COMPLETENESS OF SCANNED COPIES OF THIS PLAN SHEET.</small>					

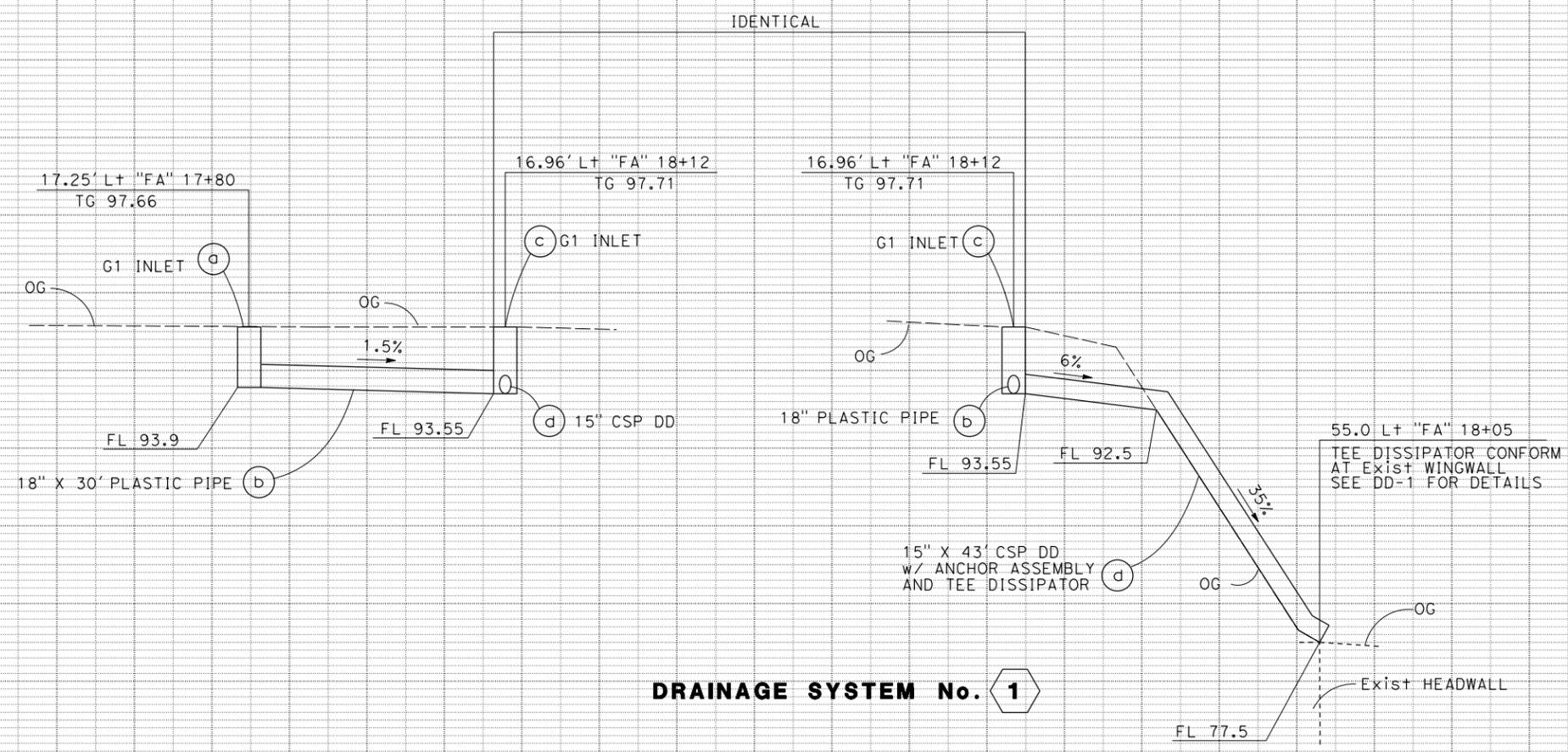

DRAINAGE SYSTEM No. 1

DRAINAGE PROFILES
 SCALE: Horiz 1" = 10'
 Vert 1" = 5'
DP-1

Dist	COUNTY	ROUTE	POST MILES TOTAL PROJECT	SHEET No.	TOTAL SHEETS
04	SM	1	0.3	8	

REGISTERED CIVIL ENGINEER	DATE
PLANS APPROVAL DATE	

THE STATE OF CALIFORNIA OR ITS OFFICERS OR AGENTS SHALL NOT BE RESPONSIBLE FOR THE ACCURACY OR COMPLETENESS OF SCANNED COPIES OF THIS PLAN SHEET.

- NOTES: (SHOULDER TRENCH PAVING)
1. COMPACTION TO BE AT 95% RELATIVE COMPACTION, SUBJECT TO TESTING.
 2. CONCRETE CAP MAY BE "RAPID SET" PCC.
 3. ALL TRENCH WORK SUBJECT TO STATE REGULATIONS AND INSPECTION.

- ABBREVIATIONS:**
- [N] = NOT A SEPARATE PAY ITEM, FOR INFORMATION ONLY
 - S = STANDARD JOINT
 - W = WATER TIGHT JOINT

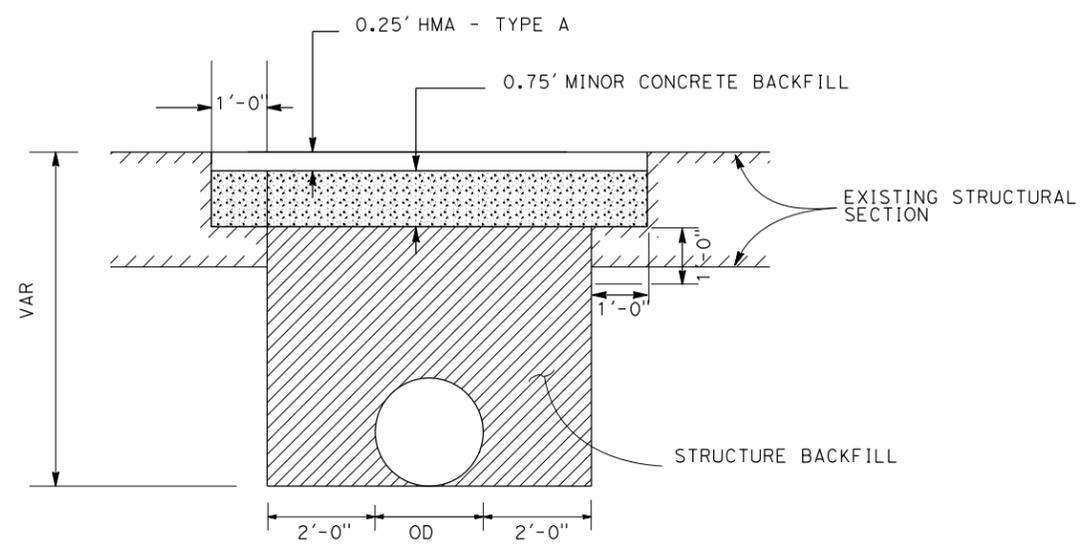

SHOULDER TRENCH PAVING

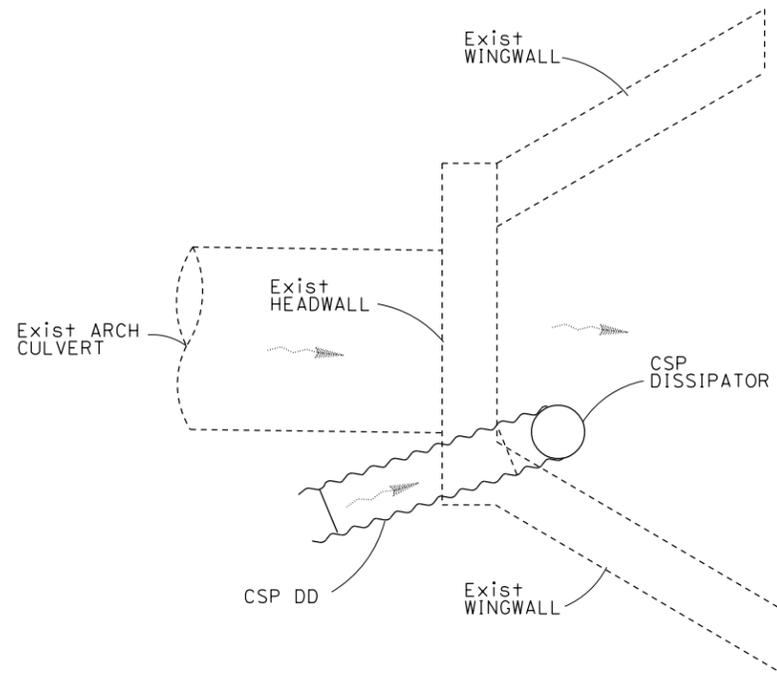
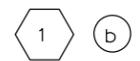

PLAN

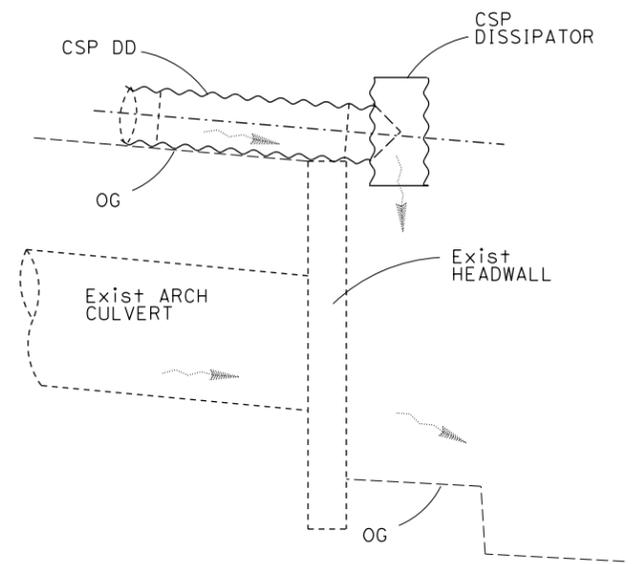

SECTION

CSP DD WITH TEE DISSIPATOR AT Exist WINGWALL



DRAINAGE QUANTITIES

DRAINAGE SYSTEM No.	DRAINAGE UNIT	STRUCTURAL CONCRETE, DRAINAGE INLET		MISCELLANEOUS IRON & STEEL (F)	18" PLASTIC PIPE	15" CSP DOWNDRAIN (0.109" THICK)	PIPE JOINT CLASSIFICATION [N]	MAXIMUM COVER [N]	HEIGHT OF INLET [N]	15" ANCHOR ASSEMBLY	MINOR CONCRETE BACKFILL	HOT MIX ASPHALT (TYPE A)	DESCRIPTION
		CY	EA										
1	a	1.16	1	239					3.93				G1 INLET
	b				30		S	2.1			6.5	4.4	18" PLASTIC PIPE
	c	1.24	1	239					4.33				G1 INLET
	d					48	W	2.5		3			15" CSP DD w/ ANCHOR ASSEMBLY AND TEE DISSIPATOR
		2.40	2	478	30	48					6.5	4.4	TOTALS

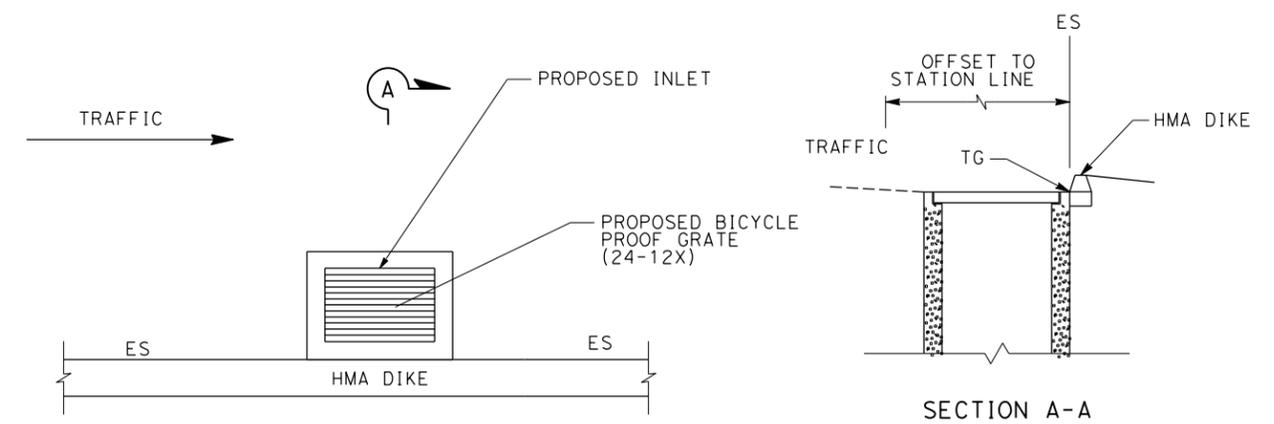

HMA DIKE



DRAINAGE DETAILS AND QUANTITIES

NO SCALE

DD-1

STATE OF CALIFORNIA - DEPARTMENT OF TRANSPORTATION - HYDRAULICS

FUNCTIONAL SUPERVISOR: DIXON LAU

REVISOR: REVISED BY DATE

CALCULATED/DESIGNED BY CHECKED BY



County of San Mateo - Planning and Building Department

ATTACHMENT D

SM 001 PM 0.64 Slope Washout

The slope washout is located at the east side of Hwy 1 PM 0.64, adjacent to Finney Creek. In the field meeting (11-01-2017), Design, Hydraulics, Geotechnical and Environmental had come to an agreement that to install multiple drainage inlets, 18" pipes and rock slope protection (RSP) to carry the runoff and discharge away from Finney Creek. Hydraulics performed an onsite survey shots on 11-07-2017. The purpose of this visit is to locate the sag point area where it caused the slope washout.

Based on our field meeting and onsite survey shots, below are Hydraulics' recommendations:

1. Cap the entrance of existing downdrain (DD) and re-establish HMA Dike.
2. Install G2 INLET at existing DD location, 2nd G2 INLET at the sag point area (60' south of existing DD) and a 3rd G2 INLET (50' south of 2nd inlet).
3. Approximate 110 feet 18" APC to connect all 3 - G2 Inlets,
4. Approximate 24' feet 18" CSP DD with 90 degree Std Elbow.
5. Install RSP (20 lb, Class I, Method B), dimension = 6' L X 6' W X 1.5' D, at discharge point.

[Figure 1:](#)

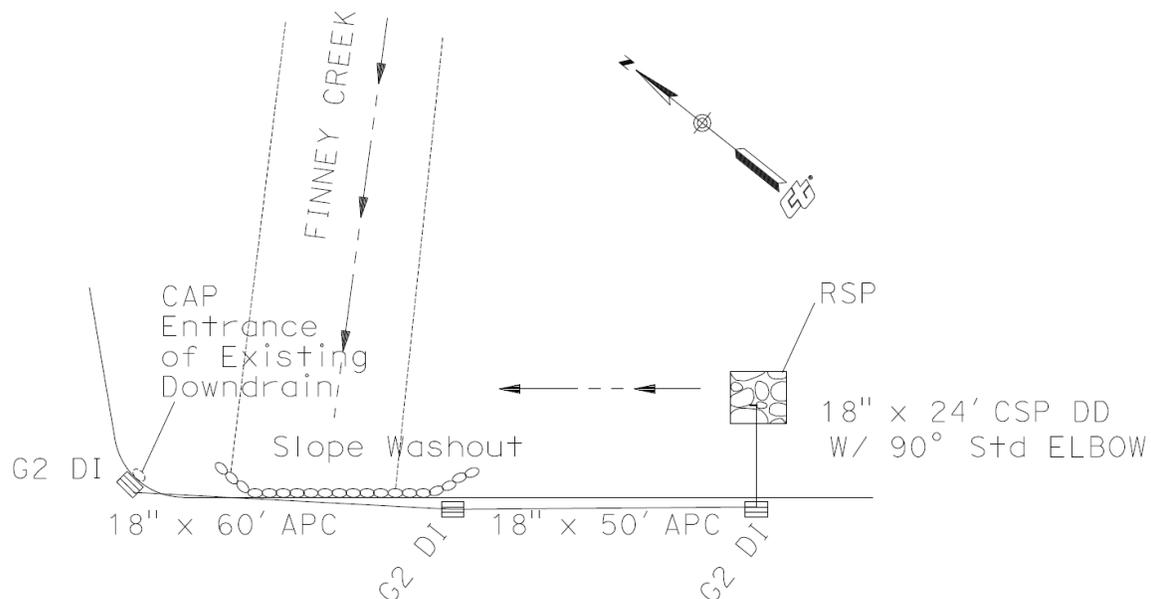



County of San Mateo - Planning and Building Department

ATTACHMENT E

Natural Environment Study



Elliot Creek Storm Damage Repair Project

Caltrans District 04

State Route 1

San Mateo County, California

04-SM-1 PM 0.3

EA 04-0J210/ID 0413000444

October 2017



Natural Environment Study
Elliot Creek Storm Damage Repair Project

Caltrans District 04
State Route 1
San Mateo County, California
04-SON-1 PM 0.3
EA 04-0J210/ID 0413000444

October 2017

Prepared By: Rachel Cotroneo Date: October 4, 2017
Rachel Cotroneo, Biologist
(510) 219-7305
CH2M HILL, Inc. (CH2M)
Oakland, CA

Reviewed By: Rene Langis Date: August 28, 2017
Rene Langis, Senior Biologist
(510)
CH2M HILL, Inc. (CH2M)
Oakland, CA

Approved By: Gregory Pera Date: 10/18/17
Gregory Pera, Branch Chief
(510) 286-5617
Office of Biological Sciences and Permits
District 04, Oakland
California Department of Transportation

Summary

The California Department of Transportation (Caltrans) proposes to repair a slip-out on the southbound side of State Route (SR) 1, Post Mile (PM) 0.3, near Elliot Creek in San Mateo County, California (Project) (see Figures 1-1 and 1-2 in Chapter 1). The slip-out was caused by stormwater runoff.

The purpose of the project is to repair a section of eroding bluff, maintain the integrity of the roadway, and improve driver safety. In addition, the section of roadway adjacent to the slip-out that is subject to repeated settlement would be repaired to improve motorist ride quality and safety.

The proposed project would require the following four actions (see Figure 1-2 in Chapter 1 and Appendix A, Plans):

- 1) Place 1,500 square feet (0.034 acre) of rock slope protection (RSP) on the bluff west of Post Mile 0.3.
- 2) Place soil over the RSP to a depth of 1 foot (1,500 cubic feet).
- 3) Revegetate disturbed soil using hydro-seed.
- 4) Install two drain inlets and dike in the southbound direction.
- 5) Correct a recurring sag point in the roadway caused by repeated settlement.

The 18.5-acre biological study area (BSA) encompasses the entire Project footprint and survey areas.

The BSA consists of the currently active highway road prism, developed bare ground, Monterey pine/riparian, pasture/grazing land, coastal bluff scrub, non-native/disturbed areas, agricultural areas, and coastal beach. The BSA is in the Santa Cruz Mountains subsection of the Central California Coast ecological subregion. The land cover in and around the Project consists primarily of developed bare ground and ruderal areas as well as brush and timber native vegetation. Elliot Creek passes beneath SR 1 from east to west, and is culverted 20 feet below the roadway. The culvert opens to the bluff about 50 feet from the edge of pavement.

Preliminary biological technical studies were conducted for the Project, and include the following:

- General species reconnaissance survey
- A special-status plant survey
- A tree inventory
- Survey for wetlands and waters

Resource Impact Summary

The Project would potentially result in impacts to the following resources:

- Federally threatened California red-legged frog (*Rana draytonii*) (CRLF) and its associated habitat and critical habitat
- Federally endangered San Francisco Garter Snake (*Thamnophis sirtalis tetrataenia*) (SFGS) and its associated habitat
- Federally threatened marbled murrelet (*Brachyramphus marmoratus*) (MAMU) and its associated habitat
- California species of special concern San Francisco Dusky-Footed Woodrat (*Neotoma fuscipes annectens*) and its associated habitat (SF DFWR)

Table S-1 summarizes anticipated impacts to these resources.

Table S-1 Anticipated Temporary Resource Impacts

Resource	Temporary Impacts (acres)	Permanent Impacts (acres)
California red-legged frog upland dispersal/critical habitat	0.018	0.034
San Francisco garter snake upland dispersal habitat	0.018	0.034
Marbled murrelet habitat	No impact anticipated	No impact anticipated
San Francisco dusky-footed woodrat habitat	0.018	0.034

Vegetation within the Project limits would be cleared and grubbed to the minimum extent necessary. The Project would temporarily impact 0.018 acre and permanently impact 0.034 acre of coastal bluff scrub (which is also CRLF potential dispersal/critical habitat, SFGS upland potential dispersal habitat, and SF DFWR woodrat habitat) within the Project footprint through installation of the RSP.

Attempts to minimize tree removal would include trimming wherever possible. The Monterey pine trees adjacent to the Project footprint are not anticipated to be impacted. Trees within the state right-of-way that are within the Project limits and conflict with Project construction would be cut down to the stumps and removed between September 30 and October 31, one year ahead of the scheduled start of construction. Clearing and grubbing would occur just prior to or during Project construction.

Caltrans is inferring presence of the CRLF, SFGS, and SF DFWR in the Project area based on results of a database search conducted for the Project, technical assistance from the U.S. Fish and Wildlife Service (USFWS), and suitable habitat identified within the Project footprint.

Final designated critical habitat for CRLF encompasses the Project footprint. The Project footprint falls inside federally designated critical habitat for CRLF but outside federally designated critical habitat for the marbled murrelet; no critical habitat has been designated for SFGS. Because the impacts of the proposed project would be localized, Caltrans has concluded that the proposed project would not adversely modify critical habitat for the California red-legged frog.

Caltrans has determined that the proposed Project:

- May affect, and is likely to adversely affect, but not jeopardize the continued existence of CRLF
- May affect, and is likely to adversely affect, but not jeopardize the continued existence of SFGS
- May affect, and is not likely to adversely affect, marbled murrelet
- Would not adversely modify designated critical habitat for CRLF, or any other listed species
- Will have no effect on western snowy plover

The Project would provide a permanent enhancement to CRLF, SFGS, and SF DFWR habitat by revegetating the RSP area with native plants.

Caltrans has determined that there would be no effect to all other federal and state listed species that may occur in the Project area (see Tables 3-1 and 3-2 in Chapter 3).

Avoidance and Minimization Measures

General and species-specific avoidance and minimization efforts will be implemented to reduce potential effects on jurisdictional features and special-status species. These measures will include minimizing the area of impact, implementing a ground disturbance work window, implementing an environmental education program for construction personnel, conducting preconstruction surveys for special-status species and nesting birds, delineating the work area and environmentally sensitive areas with fencing, maintaining presence of an onsite biological monitor during designated periods, and employing other construction-site best management practices.

Regulatory Setting

The following permits and agreements from regulatory agencies are anticipated for this Project:

- Biological Opinion for CRLF, SFGS, and marbled murrelet from the USFWS, received on September 20, 2017
- Coastal Development Permit from California Coastal Commission

Mitigation

As required by the federal Endangered Species Act, Caltrans will implement reasonable and prudent measures to minimize and avoid impacting listed species. Pursuant to procedures of the California Environmental Quality Act, Caltrans has assessed the Project's potential to impact species designated as candidate, sensitive, or special-status in local or regional plans, policies, or regulations, or by California Department of Fish and Wildlife, National Marine Fisheries Service, or USFWS.

Restoration for temporary and permanent impacts will be accomplished through revegetation onsite. No compensatory mitigation is proposed because impacts to special-status species habitat are low.

Table of Contents

Summary	v
Resource Impact Summary	vi
Avoidance and Minimization Measures	viii
Regulatory Setting	viii
Mitigation	viii
List of Abbreviated Terms	xi
Chapter 1 Introduction	1-1
1.1 Purpose and Need	1-1
1.2 Project Description	1-1
1.2.1 Sequence of Construction Activities	1-2
1.2.2 Construction Site Best Management Practices	1-10
1.2.3 Equipment	1-10
1.2.4 Construction Schedule	1-11
Chapter 2 Study Methods	2-1
2.1 Regulatory Requirements	2-1
2.2 Database and Literature Review	2-2
2.3 Technical Studies	2-3
2.3.1 Site Reconnaissance	2-3
2.3.2 Tree Survey	2-4
2.4 Survey Dates and Personnel	2-4
2.5 Agency Coordination and Professional Contacts	2-4
2.6 Limitations that May Influence Results	2-11
Chapter 3 Environmental Setting	3-1
3.1 Biological Study Area	3-1
3.2 Physical and Biological Conditions in the Biological Study Area	3-2
3.2.1 Physical Conditions	3-2
3.2.2 Biological Conditions	3-7
3.3 Regional Species and Habitats of Concern	3-10
Chapter 4 Results: Biological Resources, Discussion of Impacts, and Mitigation	4-1
4.1 General Avoidance and Minimization Measures	4-1
4.2 Natural Communities of Special Concern	4-6
4.2.1 Wetlands and Other Waters of the United States	4-6
4.2.2 Trees	4-7
4.3 Special-Status Plant Species	4-8
4.3.1 Monterey Pine (<i>Pinus radiata</i>)	4-9
4.4 Special-Status Wildlife Species Occurrences	4-11
4.4.1 California Red-legged Frog	4-11
4.4.2 San Francisco Garter Snake	4-24
4.4.3 Marbled Murrelet	4-30
4.4.4 San Francisco Dusky-Footed Woodrat	4-33
Chapter 5 Permits, Laws, Regulations, and Conclusions	5-1
5.1 Regulatory Requirements	5-1
5.2 Federal Endangered Species Act Consultation Summary	5-1
5.3 Wetlands and Other Waters Coordination Summary	5-1
5.4 Migratory Bird Treaty Act	5-2

5.5 Invasive Species 5-2
Chapter 6 **References.....6-1**

List of Tables

Table S-1 Anticipated Temporary Resource Impacts..... vi
Table 2-1 Survey Dates and Personnel 2-4
Table 3-1 Special-Status Plant Species with Potential to Occur in the Biological
Study Area 3-11
Table 3-2 Special-Status Animal Species with Potential to Occur in the
Biological Study Area..... 3-17
Table 4-1 Approximate Loss of CRLF Habitat Types 4-23
Table 4-3 Potential Impacts to SFGS Habitat 4-29
Table 4-4 Potential Impacts to SF DFWR Habitat..... 4-35

List of Figures

Figure 1-1 Project Location..... 1-3
Figure 1-2 Project Elements and Biological Study Area..... 1-5
Figure 2-1 California Natural Diversity Database Special-Status Plant Species
within 5 Miles of the BSA 2-5
Figure 2-2 California Natural Diversity Database Special Status Animal Species
within 5 Miles of the BSA 2-7
Figure 2-3 Potentially Impacted Trees 2-9
Figure 3-1 Vegetation Types within the BSA 3-3
Figure 3-2 Soil Types within the BSA 3-5
Figure 4-1 Potential Impacts to California Red-legged Frog and San Francisco
Garter Snake Habitat..... 4-17
Figure 4-2 Critical Habitat..... 4-19

List of Appendices

Appendix A Preliminary Project Construction Plans
Appendix B Photographs of the Project Footprint
Appendix D CNDDDB, CNPS, USFWS, and NMFS Species Lists
Appendix E Delineation of Wetlands and Other Waters of the United States Memo and
Plant List

List of Abbreviated Terms

°C	degree(s) Celsius
°F	degree(s) Fahrenheit
AMM	avoidance and minimization measure
BMP	best management practice
BSA	biological study area
Caltrans	California Department of Transportation
C	candidate
CCCS	Central California Coast steelhead
CDFG	California Department of Fish and Game
CDFW	California Department of Fish and Wildlife
CEQA	California Environmental Quality Act
CESA	California Endangered Species Act of 1984
CFR	Code of Federal Regulations
CFS	California freshwater shrimp
CH2M	CH2M HILL, Inc.
CIDH	cast-in-drilled-hole
CNDDDB	California Natural Diversity Database
CNPS	California Native Plant Society
CRLF	California red-legged frog
CT	condition threatened
CTS	California tiger salamander
DPS	Distinct Population Segment
EA	Expenditure Authorization
ESA	environmentally sensitive area
ESU	evolutionarily significant unit
FE	federally endangered
FESA	federal Endangered Species Act
F.G.C.	California Fish and Game Code

FP	fully protected
FT	federally threatened
ft ²	square feet
ITP	Incidental Take Permit
LCP	Marin County Local Coastal Program
LSA	LSA Associates, Inc.
MAMU	marbled murrelet
MBTA	Migratory Bird Treaty Act
NES	Natural Environment Study
NMFS	National Marine Fisheries Service
NRCS	Natural Resources Conservation Service
OHWM	ordinary high water mark
PBO	Programmatic Biological Opinion
PM	post mile
psu	Practical Salinity Unit
SE	state endangered
SFGS	San Francisco garter snake
ST	state threatened
SR	state route
SRPCS	Santa Rosa Plain Conservation Strategy
SSC	state species of special concern
SWPPP	Stormwater Pollution Prevention Plan
TCE	temporary construction easement
USACE	U.S. Army Corps of Engineers
U.S.C.	U.S. Code
USDOT	U.S. Department of Transportation
USEPA	U.S. Environmental Protection Agency
USFWS	U.S. Fish and Wildlife Service
USGS	U.S. Geological Survey
WEF	wildlife exclusion fencing

Chapter 1 Introduction

The California Department of Transportation (Caltrans) proposes to repair a slip-out on the southbound side of State Route (SR) 1, Post Mile (PM) 0.3, near Elliot Creek in San Mateo County, California (Project) (Figures 1-1 and 1-2). The slip-out was caused by stormwater runoff. Additionally, the section of roadway adjacent to the slip-out that is subject to repeated settlement would be repaired to improve motorist ride quality and safety. This section of highway is a two-lane highway (one lane in each direction). For detailed Project plans see Appendix A, and for photographs of the Project location see Appendix B.

The Project is in the Santa Cruz Mountains subsection of the Central California Coast ecological subregion. The land cover in and around the Project footprint consists primarily of developed bare ground and ruderal areas, as well as brush and timber native vegetation. Elliot Creek passes beneath SR 1 from east to west and is culverted 20 feet below the roadway. The culvert opens to the bluff about 50 feet from the edge of pavement.

This Natural Environment Study (NES) provides technical information to determine the extent to which the Project may affect plants, animals, and natural communities occurring in the biological study area (BSA), including special-status species, potentially jurisdictional wetlands and waters, and protected natural plant communities. This NES provides technical information that will supplement future Project impact decisions.

1.1 Purpose and Need

The purpose and need of the Project is to correct existing storm damage, prevent future erosion, maintain the integrity of the roadway, and enhance driver safety. Additionally, motorist ride quality and safety needs to be improved through the section of roadway that repeatedly experiences settlement. The project was initiated by a Damage Assessment Form on June 19, 2013, regarding damages that occurred due to soil saturation.

1.2 Project Description

Caltrans proposes to repair a slip-out on the southbound side of SR 1, PM 0.3, near Elliot Creek in San Mateo County, California (see Figures 1-1 and 1-2). The slipout was caused by storm water runoff. Additionally, the section of roadway adjacent to

the slip-out that is subject to repeated settlement would be repaired to improve motorist ride quality and safety. This section of highway is a two-lane highway (one lane in each direction).

The proposed Project elements (see Figure 1-2 and Appendix A) include:

- Placing 1,500 square feet (0.034 acre) of rock slope protection (RSP) on the bluff west of PM 0.3
- Placing 1,500 cubic feet of soil over the RSP, to a depth of 1 foot
- Revegetating disturbed soil
- Installing two drain inlets and an asphalt concrete dike in the southbound direction, and
- Correcting a recurring sag point in the roadway caused by repeated settlement

1.2.1 Sequence of Construction Activities

Construction work would occur in the general order discussed below.

1.2.1.1 SITE PREPARATION

A U.S. Fish and Wildlife Service (USFWS)/California Department of Fish and Wildlife (CDFW)-approved biological monitor would be present during site preparation activities before starting construction, including:

- Vegetation trimming during the non-nesting season for migratory birds
- Installation of environmentally sensitive area (ESA) fencing
- Installation of wildlife exclusion fencing (WEF)

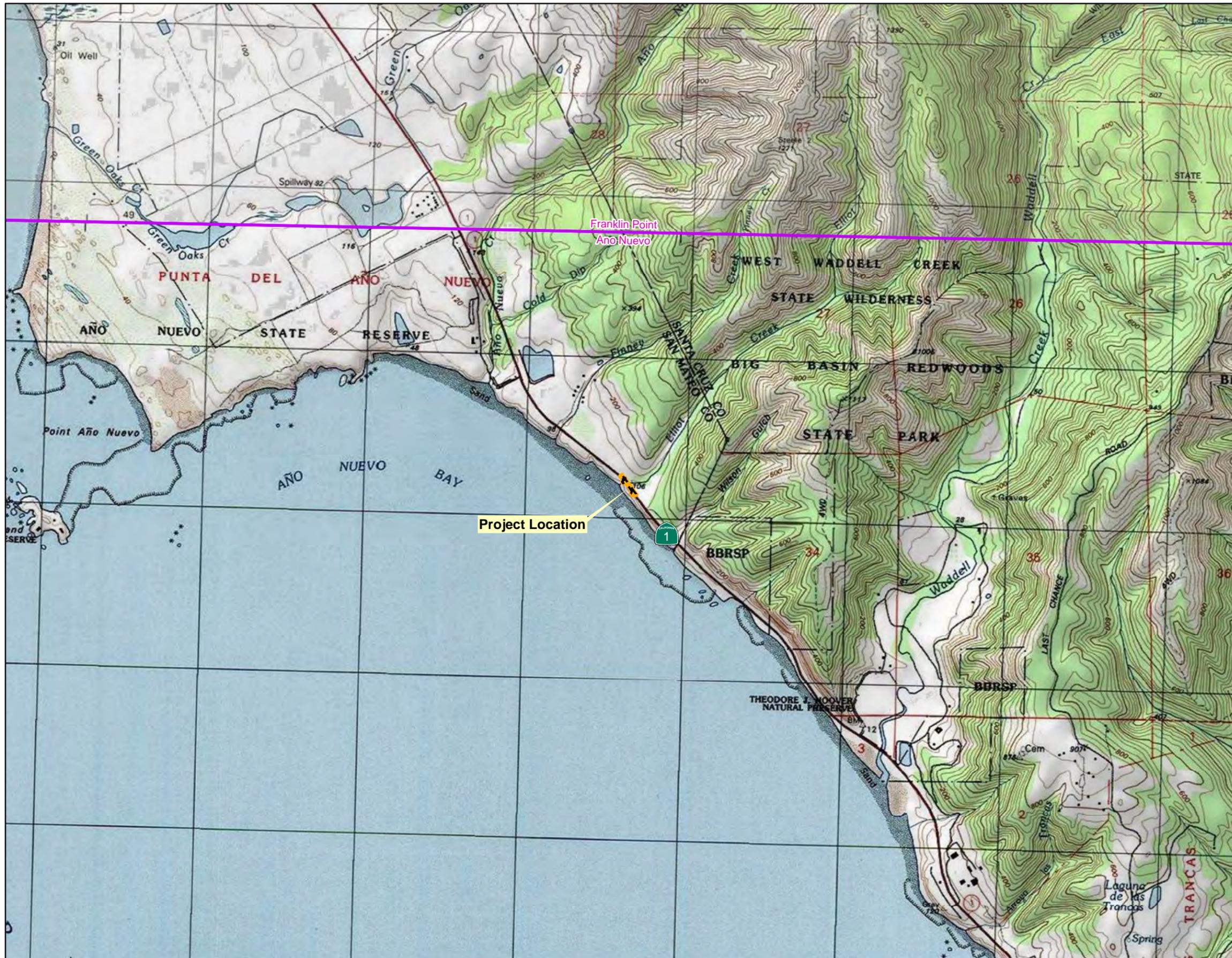

- LEGEND**
- Project Location
 - USGS 7.5 Minute Quadrangle

Service Layer Credits:
 Copyright: © 2013 National Geographic Society, i-cubed
 Content may not reflect National Geographic's current map policy. Sources:
 National Geographic, Esri, DeLorme, HERE, UNEP-WCMC, USGS, NASA,
 ESA, METI, NRCAN, GEBCO, NOAA, increment P Corp.

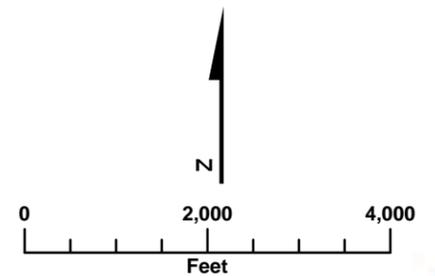

FIGURE 1-1
Project Location
 Elliot Creek Storm Damage Project
 EA 0J201, SAN-1-Post Mile 0.01 - 0.3
 San Mateo County, California



- LEGEND**
-  Project Footprint (0.53 acre)
 -  Biological Study Area (BSA)(18.5 acres)
 -  Proposed Pipe Culvert
 -  Proposed Earthen Berm
 -  Existing Arched Pipe Culvert (0.021 acre)
 -  Proposed Road Patch (0.028 acre)
 -  Proposed Staging Area
 -  Proposed RSP Placement (0.034 acre)
 -  Proposed Drainage Inlet
 -  Elliot Creek

Service Layer Credits:
 Source: Esri, DigitalGlobe, GeoEye, Earthstar Geographics, CNES/Airbus DS, USDA, USGS, AeroGRID, IGN, and the GIS User Community
 Content may not reflect National Geographic's current map policy. Sources: National Geographic, Esri, DeLorme, HERE, UNEP-WCMC, USGS, NASA, ESA, METI, NRCAN, GEBCO, NOAA, increment P Corp.

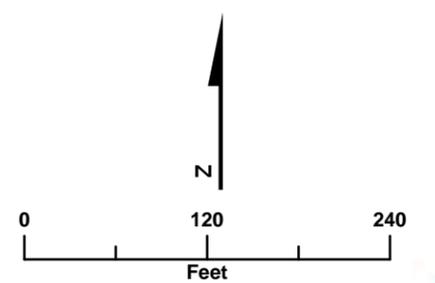

FIGURE 1-2
Project Elements and BSA
 Elliot Creek Storm Damage Project
 EA 0J201, SAN-1-Post Mile 0.01 - 0.3
 San Mateo County, California

The ESA fencing and WEF would line the Project footprint, or as the USFWS deems appropriate during consultation. ESA fencing would be maintained throughout construction and removed at the end of construction activities. The final Project plans will show where and how the ESA and WEF are to be installed. The bid solicitation package special provisions will provide further instructions to the contractor about acceptable fencing material.

Tree trimming and removal would be required to allow construction access to the proposed RSP area. Non-invasive/native trees that interfere with Project construction would be cut to allow sprouting from the trunk. Invasive trees would be removed to reduce the chance of regrowth. Temporarily affected areas would be regraded to preconstruction contours or to match surrounding topography, to the extent practicable and where feasible. After completing the RSP, permanent erosion control measures would be applied to all disturbed soil areas.

Trimming and limbing would be scheduled to occur outside the February 1 to September 30 bird-nesting season. If for any reason this schedule cannot be met, surveys for nesting migratory birds would be conducted before clearing begins. Nest avoidance requirements of the Migratory Bird Treaty Act (MBTA) and California Fish and Game Code (F.G.C.) would be observed. A biological monitor would survey the Project area before clearing starts and would be present onsite during vegetation removal to inspect for federally listed species and migratory birds, and to verify that clearing is done according to the contract special provisions and permits.

1.2.1.2 STAGING AREAS

Construction equipment and excavated material would be stored onsite in the staging area approximately 240 feet south of the work area. The staging area measures approximately 0.087 acre and consists of 0.07 acre of soil and 0.017 acre of asphalt concrete pavement (Figure 1-2 and Appendix B).

1.2.1.3 UTILITIES RELOCATION

Existing utilities would not be impacted or relocated.

1.2.1.4 PROPOSED CONSTRUCTION

Vegetation Removal

The Project proposes to clear an area measuring 0.034 acre, located on the bluff on the west side of SR 1. An extra 0.014 acre surrounding the 0.034 acre of RSP would be included to account for vegetation trampling, thereby making the total vegetation disturbance 0.048 acre. The vegetation would be removed using hand tools, followed

by heavy equipment. Native vegetation that is removed would be reused at the end of the Project within the work area.

Excavation and Slope Stabilization

Slip-out repair would include at least 1 foot of excavation into competent material and would go down to a maximum depth of 5 feet, thereby making the total volume of soil removal approximately 278 cubic yards. Equipment for excavation would include a mini excavator, front-end loader, backhoe, water truck, and a dump truck. The RSP would have a maximum thickness of 7 feet (but not more than 5 feet of excavation) and would be placed using mechanical tools. A “key” (footing trench) would be constructed at the bottom of the slope and would extend the footing trench a minimum of 10 feet beyond the eroded area of slope (within the 30-foot by 50-foot RSP area). The minimum depth of the key would be 5 feet. The bottom of the excavation would be covered with nonwoven RSP fabric and ¼-T (1/4 ton) class rock would be used. Placement of the RSP would be by “Method A,” which is the placement of individual rocks. Enough rock courses would be placed to a grade approximately 2 feet below the slope prior to the erosion. Voids would be filled in with native soil and placed to a height of 1 foot above the RSP and would match the contours of existing ground.

Drainage

Roadway drainage would consist of constructing two drain inlets in the shoulder spaced approximately 32 feet apart and connected by an 18-inch plastic pipe. A 15-inch corrugated steel pipe down drain 48 feet long connected to the first drain inlet would run down the embankment, then over the existing arch culvert end wall, and would drain into the arch culvert concrete spillway. A 2-foot-wide earth berm would be constructed along the edge of pavement to act as a natural barrier and blend into the existing ground beyond the shoulder. A 60-foot asphalt concrete dike would be constructed along the back of the shoulder in front of the earth berm to prevent further erosion and direct roadway runoff into the drain inlets.

RSP drainage would consist of an 8-inch-diameter perforated plastic pipe, encapsulated in permeable material, and wrapped in filter fabric running along the bottom of the RSP, inside the key. Connected to the end of the 8-inch perforated plastic pipe would be an 8-inch plastic pipe connected to the 15-inch CSP down drain.

Pavement Rehabilitation

Caltrans proposes to repair a sag point in the road that spans both lanes of traffic. This area of asphalt measures approximately 24 feet by 50 feet, an area of 1,200 square feet or 0.028 acre. Although there is an arch culvert in Elliot Creek to carry stormwater from the east side to the west side of SR 1, throughout the years, water naturally has been seeping through from the east side to the west side, carrying fines with it. This has caused voids and led to recurring settlement of the roadway above. This repeated settlement creates dips in the roadbed that require repeated resurfacing to fill. The California Highway Patrol has contacted Caltrans to request a correction to this situation. Caltrans proposes to inject styrofoam through drilled holes in the pavement and fill in the voids at varying depths, creating sufficient pressure to stop the seepage and support the roadway above and eliminating the settlement problem. This solution is less disruptive to traffic because it does not require extensive roadway reconstruction and is a much quieter and quicker option than reconstructing the roadway. It is expected that this method would not require roadway reconstruction and would require a truck-mounted drill (approximately 3-inch diameter) and truck-mounted styrofoam pump. Duration of styrofoam injection process would take approximately 3 to 5 days. If the roadway has experienced settlement at the time of construction, then the area would need to be resurfaced.

Lane Closure

Temporary lane closures would be established to create necessary workspace for construction and would require installing a temporary signal system for single-lane, two-way traffic control. Additional traffic control measures would include construction-area signs, flashing beacons, traffic cones, portable changeable message signs, and flaggers. One lane would be closed for the duration of the RSP and roadway repair work. Temporary railing (Type K) would be used for construction safety and would remain in place until no longer needed.

1.2.1.5 SITE CLEANUP AND RESTORATION

Construction-related materials including the WEF and ESA fencing would be removed after construction activities have been completed. The temporarily disturbed areas would be revegetated with appropriate native species, to the extent practicable. Permanent erosion control, including soil stabilization measures such as hydro-seeding, coir netting, and non-filament mesh fiber rolls, would be applied to affected areas to minimize erosion after construction has been completed.

1.2.1.6 REVEGETATION PLANTING

All construction-related materials would be removed after completion of construction activities. Temporarily disturbed areas would be restored to pre-construction conditions, and any remaining excavated soil would be disposed of at an approved disposal site or upland location.

The excess native soil would be stored in the staging area and used to fill in the RSP voids and to provide a 1-foot natural cover over the RSP, which would then be hydro-seeded using a native plant erosion control mix. Additionally, large woody native vegetation removed at the start of excavation would be placed on top of the soil to act as natural ground cover. Invasive, non-native plants, duff, and excavated material containing invasive plant material would be cleared from the Project footprint.

Tree and shrub planting would occur as a separate revegetation project after this roadway construction project is completed. Trees removed would be replaced at the following ratios: 3:1 for native riparian trees that have a diameter at breast height greater than 4 inches and 1:1 for non-native trees.

1.2.2 Construction Site Best Management Practices

Temporary and permanent erosion control measures would be implemented per Caltrans Construction Standard best management practices (BMPs). Silt fencing or other erosion control measures would be installed to prevent sediment and pollutant discharges to state and federal waters. BMPs include:

- Perimeter control methods (fiber rolls and silt fences) would be placed along the downhill side of haul roads.
- Temporary stockpiling on the embankment would be avoided.
- Disturbed areas will be revegetated with appropriate native, non-invasive species that would serve to stabilize the site.

1.2.3 Equipment

Clearing and grubbing would be completed by hand using small mechanical tools or by using backhoes and excavators, followed by heavy equipment for slip-out excavation. Equipment for excavation would include a mini excavator, backhoe/loader, excavator, water truck, and a dump truck. A saw cutter, backhoe, jumping jack compactor, and dump truck would be used to install roadway drainage features (two drain inlets and culvert). To repair the sag point in the road, Caltrans

proposes to use a truck-mounted drill (approximately 3-inch diameter) and a truck-mounted styrofoam pump. If the roadway has experienced settlement at the time of construction, then the area would be resurfaced, which would require a dump truck and asphalt paver.

1.2.4 Construction Schedule

Trees would be cut and removed prior to construction to minimize effects on nesting birds. No grubbing would occur during this period.

Work would be restricted to the dry season work window of June 1 to October 31. This window is designed to avoid the time of year when some protected wildlife is most active.

Construction is expected to begin in July 2018. No night work is expected. A traffic management plan would be prepared prior to construction. All construction-related activities would take place within Caltrans' right-of-way.

The Project would require a total of 40 working days (8 weeks), allowing it to be completed within a single construction season.

Chapter 2 Study Methods

To prepare this NES, Caltrans and consultant biologists reviewed various databases, historical records, and other scientific literature to develop the environmental baseline for the area of the proposed Project. Technical assistance also was requested from federal resource agencies. A BSA was determined prior to conducting field studies. The BSA includes the area within the Project footprint plus the additional survey area necessary to assess existing natural resources and identify the following:

- Plant community and habitat types
- Potential wetlands
- Potential presence of special-status species
- Need for further in-depth or protocol-level surveys

2.1 Regulatory Requirements

Project implementation would affect natural resources within the jurisdiction of the following federal and state agencies:

- USFWS (Sacramento District Office)
- California Coastal Commission

Federal regulatory requirements and laws that apply to the proposed Project include the following:

- National Environmental Policy Act (42 U.S. Code [U.S.C.] § 4321)
- Federal Endangered Species Act (FESA) (16 U.S.C. § 1531)
- Clean Water Act, Sections 401 (33 U.S.C. § 1341) and 404 (33 U.S.C. § 1344)
- MBTA (16 U.S.C. § 703-712)
- Magnuson-Stevens Act (16 U.S.C. § 1801-1884)
- Bald and Golden Eagle Protection Act (16 U.S.C. § 668 et seq.)
- Executive Order 11990 (Protection of Wetlands) (42 *Code of Federal Regulations* [CFR] 26921)

- Executive Order 13112 (Invasive Species) (64 CFR 6183)

Applicable state laws and regulations include the following:

- California Environmental Quality Act (CEQA) (Public Resources Code § 21000 et seq.)
- California Endangered Species Act of 1984 (CESA) (F.G.C. § 2050 et seq.)
- Native Plant Protection Act of 1977 (F.G.C. §§ 1900-1913)
- Lake and Streambed Alteration Agreement (F.G.C. §§ 1600-1616)
- Protection of Migratory Birds (F.G.C. § 3503, 3515, and 3800)
- State Senate Bill 857 (fish passage) (F.G.C. § 5901)

2.2 Database and Literature Review

A literature review was conducted to investigate the potential presence of sensitive resources, special-status species, and critical habitat(s) within the BSA and vicinity. A regional list of special-status wildlife and plant species was developed by querying the following databases, and each species was then evaluated to determine its potential to occur within the BSA:

- A species list from the USFWS (2017) was generated for the following six U.S. Geological Survey (USGS) 7.5-minute quadrangles: Ano Nuevo (3712213), Pigeon Point (3712224), Franklin Point (3712223), Big Basin (3712222), Davenport (3712212), and Santa Cruz (3612281).
- A species list from the National Marine Fisheries Service (NMFS) (2017) was generated for the Ano Nuevo (3712213) USGS 7.5-minute quadrangles.
- The California Native Plant Society (CNPS) Inventory of Rare and Endangered Plants of California database was searched for the same six quadrangles listed above (CNPS 2017) for special-status plant species.
- The California Natural Diversity Database (CNDDDB) (CDFW 2017) was queried for all special-status plant and wildlife species occurrence records within 5 miles of the BSA (Figures 2-1 and 2-2).

- The National Wetlands Inventory database (USFWS 2016) was reviewed for wetlands analysis and potential habitat for special-status aquatic species analysis.
- The U.S. Department of Agriculture’s Natural Resources Conservation Service (NRCS) soils information was reviewed and maps were created (NRCS 2016a) for wetlands analysis and potential habitat for special-status plant species analysis.
- Climate information was obtained from the Western Regional Climate Center (2017) for wetlands analysis.
- The California State Clearinghouse CEQAnet database was reviewed for projects in Sonoma County between August 2016 and August 2017 for wetlands and special-status wildlife and plant species cumulative impact analysis.

Results from the searches informed the preliminary technical studies that were conducted to evaluate special-status species and resources for this NES. The result of the special-status species’ evaluations, including species potential for occurrence, is provided in Tables 3-1 and 3-2 in Chapter 3, and Appendix C, Species Lists. The results of sensitive resources evaluated for this NES are provided in Section 4.2.

2.3 Technical Studies

Various studies were conducted in the preparation of this NES. Studies included surveys of protected resources and special-status species; these are described in the following subsections.

2.3.1 Site Reconnaissance

Caltrans biologists Elizabeth Leyvas and Mita Nagarkar visited the site on April 27, 2017, and CH2M biologists Rachel Cotroneo and Caprice Lee visited the site on July 27, 2017, to conduct site reconnaissance within the BSA. The surveys were conducted to assess potential for rare plants and to determine presence of jurisdictional wetlands. It was determined that hydrophytic vegetation, hydric soils, and wetland hydrology was not present within the Project footprint, and Elliot Creek is the only jurisdictional water within the BSA.

All plant species encountered during the botanical survey were identified to the extent necessary to determine if they met the criteria as a federal- or state-listed rare, threatened, or endangered species under FESA, CESA, CNPS, or CEQA.

The survey report, along with a plant list, is included in Appendix D.

2.3.2 Tree Survey

A survey of tree species within the BSA was conducted on July 27, 2017, by CH2M biologists Rachel Cotroneo and Caprice Lee. Figure 2-3 presents trees that the Project would impact.

2.4 Survey Dates and Personnel

Table 2-1 summarizes the personnel and survey dates of each of the field studies.

Table 2-1 Survey Dates and Personnel

Survey Type	Date(s)	Objective	Personnel
Biological Reconnaissance Survey	January 9, 2017	Initial site assessment, wetlands, waters and rare plant assessment	Caltrans biologists Elizabeth Leyvas and Mita Nagarkar
Wetlands Waters and Rare Plant Survey	April 27, 2017	Wetlands, waters and rare plant assessment	Caltrans biologists Elizabeth Leyvas and Mita Nagarkar
Tree Survey, Rare Plant Survey	July 27, 2017	Additional site assessment, tree survey wetlands, waters and rare plant assessment	CH2M biologists Rachel Cotroneo and Caprice Lee

2.5 Agency Coordination and Professional Contacts

Various agency personnel have been consulted in the process of conducting field studies and preparing the environmental documents needed for this Project:

- Elizabeth Leyvas, Caltrans biologist, initiated technical assistance from John Cleckler of USFWS on January 30, 2017.
- Elizabeth Leyvas, Caltrans biologist, spoke by phone with U.S. Army Corps of Engineers (USACE) liaison Janelle Leeson on February 8, 2017. It was determined that Elliot Creek is under USACE jurisdiction but that neither a Section 404 nor Section 10 permit is needed because no work would be conducted below the ordinary high water mark of Elliot Creek.

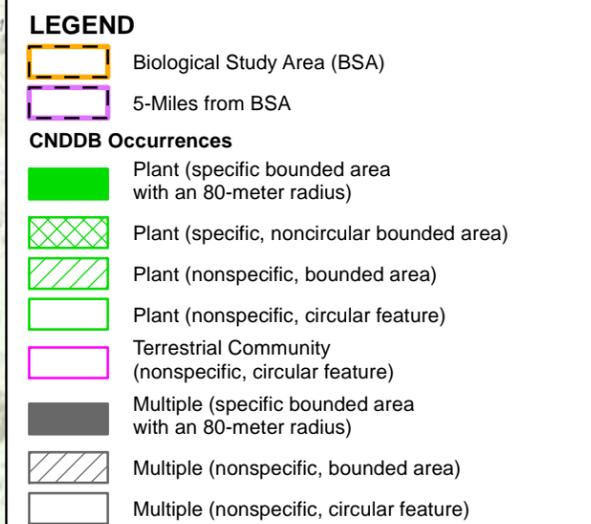
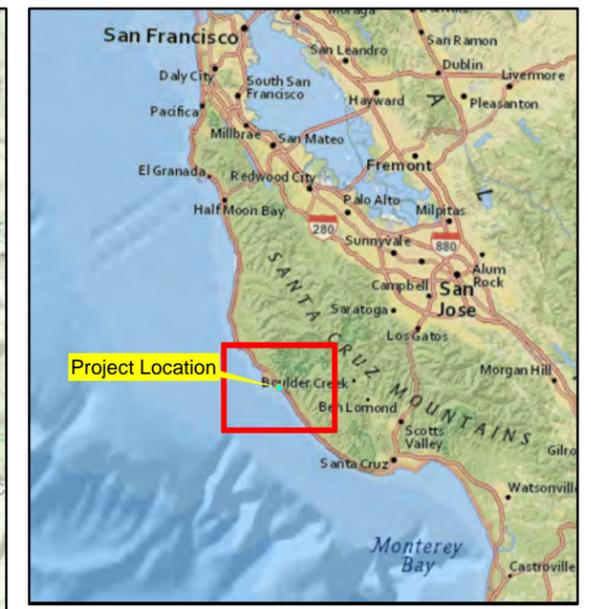
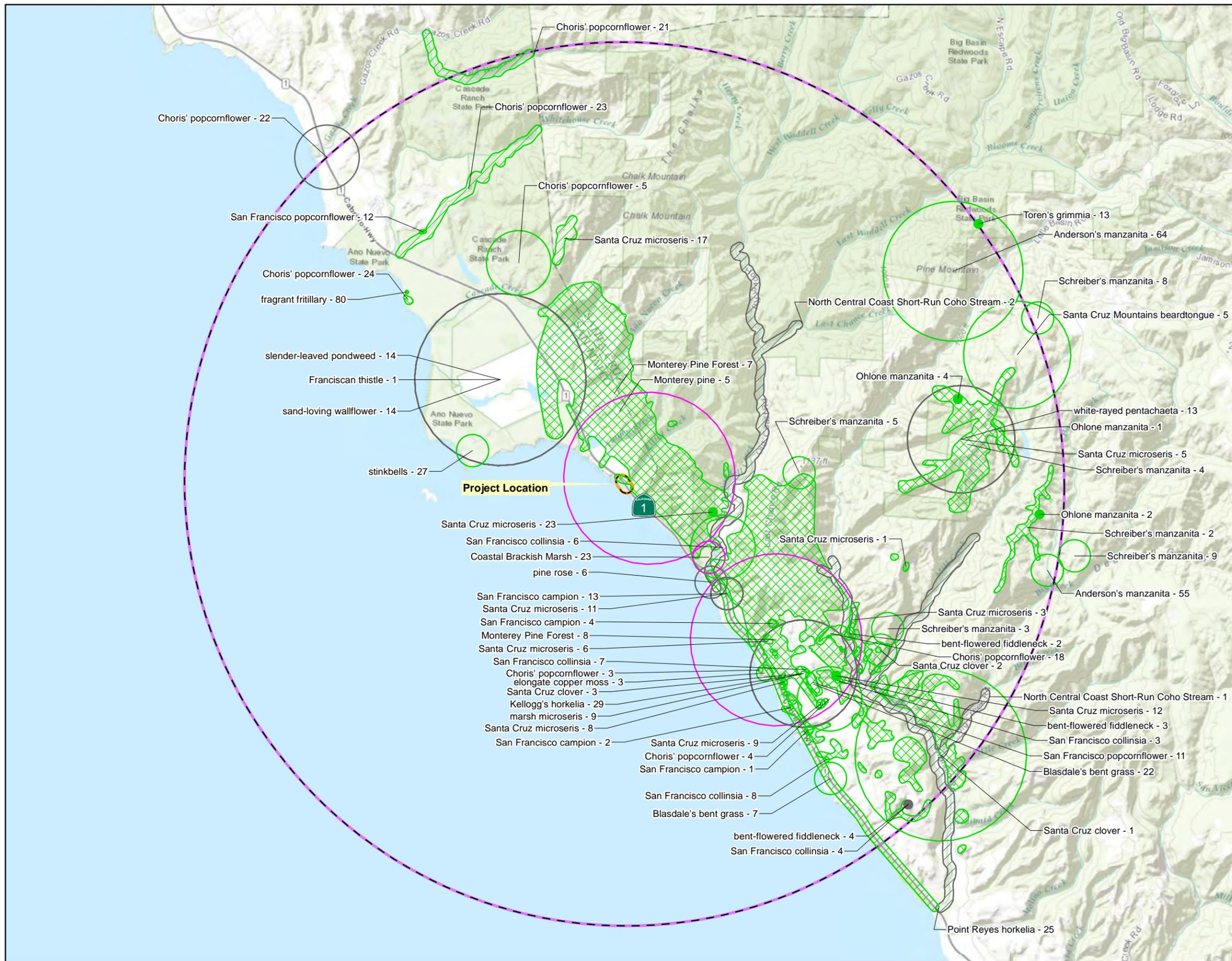

Note:
 CNDDDB version July 2017.
 The occurrences shown on this map represent the known locations of the species listed here as of the date of this version. There may be additional occurrences or additional species within this area which have not yet been surveyed and/or mapped. Lack of information in the CNDDDB about a species or an area can never be used as proof that no special status species occur in an area.

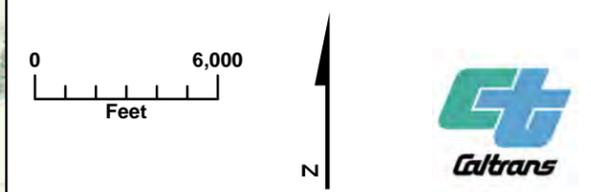

FIGURE 2-1
California Natural Diversity Database (CNDDDB) Plant Species within 5 Miles of the BSA
 Elliot Creek Storm Damage Project
 EA 0J201, SAN-1-Post Mile 0.01 - 0.3
 San Mateo County, California



- LEGEND**
-  Project Footprint
 -  Permanent Impact Area
 -  Temporary Impact Area
 -  Dead Tree
 -  Monterey Cypress
 -  Monterey Pine
 -  Impacted Trees

Service Layer Credits:
 Source: Esri, DigitalGlobe, GeoEye, Earthstar Geographics, CNES/Airbus DS, USDA, USGS, AeroGRID, IGN, and the GIS User Community
 Content may not reflect National Geographic's current map policy. Sources: National Geographic, Esri, DeLorme, HERE, UNEP-WCMC, USGS, NASA, ESA, METI, NRCAN, GEBCO, NOAA, increment P Corp.

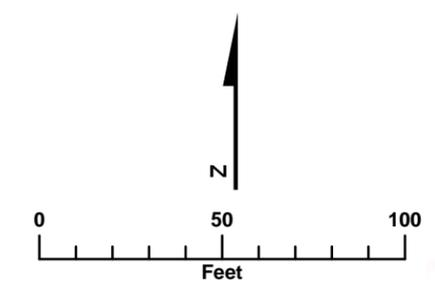

FIGURE 2-3
Potentially Impacted Trees
 Elliot Creek Storm Damage Project
 EA 0J201, SAN-1-Post Mile 0.01 - 0.3
 San Mateo County, California

- Elizabeth Leyvas of Caltrans, Peter Aguilera of Caltrans, Mita Nagarkar of Caltrans, Susana Onate of Caltrans, and John Cleckler of USFWS met at the site on April 27, 2017. Impacts to special status species were discussed.
- On August 17, 2017, Caltrans sent the USFWS a letter and a Biological Assessment for California red-legged frog, San Francisco Garter Snake and Marbled Murrelet, requesting concurrence with the following determinations: the Project may affect and is likely to adversely affect California red-legged frog and San Francisco garter snake, and is not likely to adversely affect marbled murrelet.
- On August 21, 2017 Caltrans received an email from John Cleckler of USFWS requesting additional information about the Project. Mr. Cleckler mentioned that the email was equivalent to a 30-day letter.
- On September 20, 2017, Caltrans received the Biological Opinion for the Elliot Creek Storm Damage Project, Caltrans ES 0J210, from USFWS.

2.6 Limitations that May Influence Results

The potential for state- and federally listed wildlife species to occur within the BSA was based on the evaluation of habitat suitability for target species during field surveys and not protocol-level surveys. Field surveys were augmented through a review of authoritative databases (such as CNDDDB) for species occurrences in the Project vicinity, previous and current habitat assessments and reconnaissance-level site visits, and review of aerial photographs. Presence of California red-legged frog and San Francisco garter snake, was inferred due to the proximity of water bodies, suitable dispersal habitat, critical habitat, and CNDDDB occurrences.

There were no restrictions on access for surveys of wetlands or special-status species and their associated habitats. Surveys were performed during the appropriate seasons and according to professional standards.

Chapter 3 Environmental Setting

This chapter provides a description of the BSA and its physical and biological conditions.

3.1 Biological Study Area

The Project is in San Mateo County, California, located at PM 0.3 on a bluff on SR 1 overlooking the Pacific coast (Figure 1-1), 0.3 mile north of the Santa Cruz County line. The Project is located within the Caltrans right-of-way and within the Año Nuevo USGS 7.5-minute topographic quadrangle.

The following terms have been used to describe the Project:

- Project area/Project footprint: The Project limits, also referred to as the Project area or the Project footprint, is defined as the entire area of direct and indirect impacts from the Project, including the areas within the Caltrans right-of-way. Indirect impacts, such as siltation downstream from construction disturbance, can sometimes occur, but as discussed in Section 4.2.1.3, Project Impacts, potential indirect impacts would be avoided through the use of BMPs.
- Biological Study Area: The BSA established for the Project encompasses the Project limits with a 350-foot buffer.

The BSA includes the currently active highway road prism, developed bare ground, Monterey pine/riparian, pasture/grazing land, coastal bluff scrub, non-native/disturbed areas, agricultural areas, and coastal beach (Figure 3-1). The BSA is in the Santa Cruz Mountains subsection of the Central California Coast ecological subregion (Miles and Goudey 1997). This region is characterized by gently sloping to steep, low mountains. The coastal plains are narrow and discontinuous, and stream valleys are narrow and widely separated. Elevation ranges from sea level to 2,650 feet (810 meters) in most of the area, but it is 4,950 feet (1,510 meters) in some of the mountains.

The land cover around and associated with the Project footprint primarily consists of developed bare ground and ruderal areas, as well as brush and timber native vegetation.

Elliot Creek passes beneath SR 1 from east to west and is culverted 20 feet below the roadway. The culvert opens to the bluff about 50 feet from the edge of pavement.

3.2 Physical and Biological Conditions in the Biological Study Area

The Project footprint is 0.53 acre and the BSA is 18.5 acres. The Project falls within the Año Nuevo USGS 7.5-minute topographic quadrangle at 37°06'40.2300"N and 122°17'46.6440"W World Geodetic System 1984 geodetic datum (WGS84). The township and range is 09S and 04W, Section 34 of the Mount Diablo meridian.

3.2.1 Physical Conditions

3.2.1.1 TOPOGRAPHY

The Project is located within the Santa Cruz Mountain subsection of the Central California Coast ecological subregion. This subsection is the western and southwestern parts of the Santa Cruz Mountains, between the San Andreas fault and the Pacific Ocean. This is a subsection of northwest-trending mountains with rounded ridges, steep sides, and narrow canyons. Most of the streams drain toward the southwest (Miles and Goudy 1997).

3.2.1.2 SOILS

Soil types in the BSA were obtained from the NRCS Web Soil Survey (NRCS 2017a) and the Official Soil Series Descriptions (NRCS 2017b). All soils colors included in the descriptions are indicative of moist soils.

The following soil types occur within the BSA, in the order of descending area: Santa Lucia loam, Lockwood loam, coastal beaches, terrace escarpments, Colma sandy loam, and Tierra loam. The soil types found directly in the Project footprint are Lockwood loam (71 percent), Santa Lucia loam (27 percent), and Tierra loam (2 percent). all of which are gently sloping at a 3 to 6 percent incline (Figure 3-2).

The Lockwood series consists of very deep, well-drained soils that formed on alluvial material from dominantly siliceous shales. Lockwood soils are on alluvial fans and bench terraces and have slopes of 0 to 15 percent. Lockwood loam contains shale fragments that make up 15 to 35 percent of the soil at depths of 10 to 40 inches. In a typical profile, the soil at the surface is a very strongly acidic, very dark grayish brown (10YR 3/2) to a depth of 3 inches. From 3 to 16 inches the soils is a slightly acidic, very dark brown (10YR 2/2) shaley loam. From 16 to 26 inches the soil is a

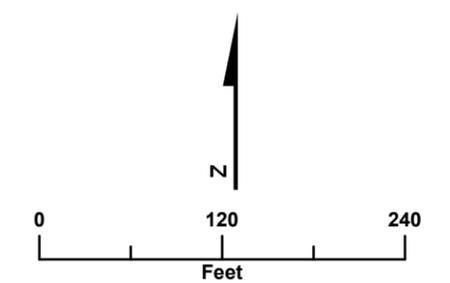
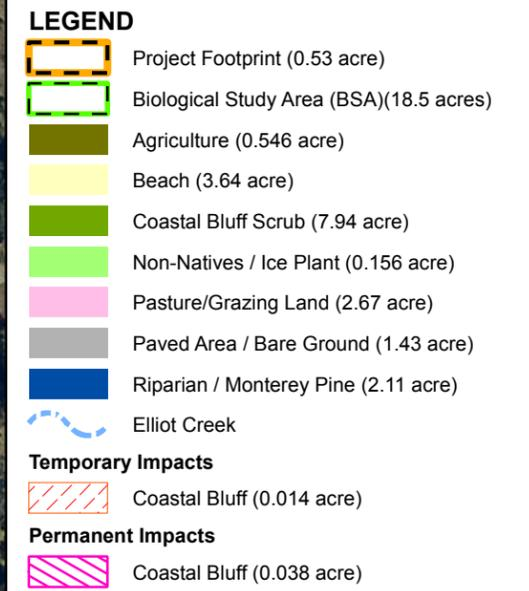
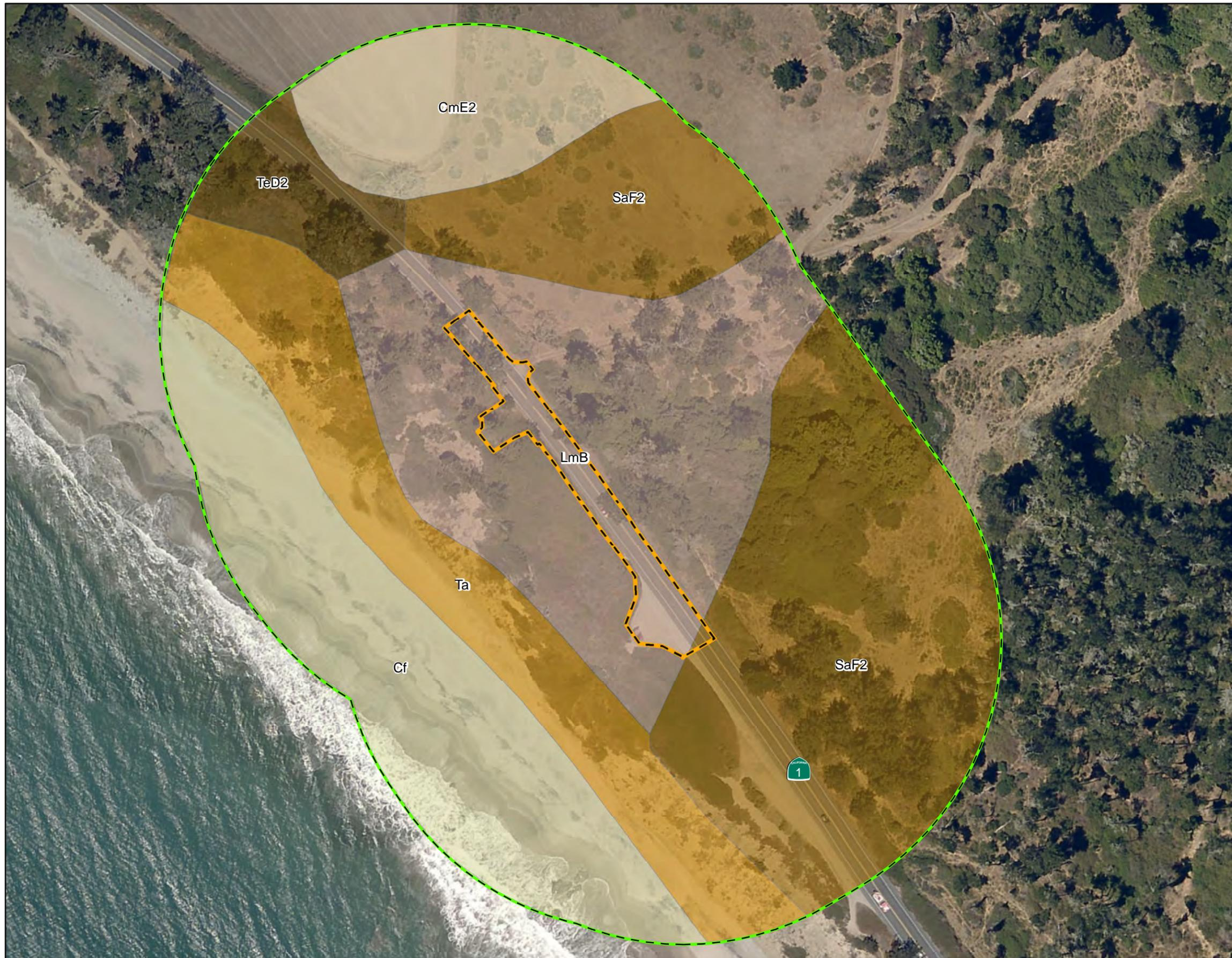

FIGURE 3-1
Vegetation Types and
Impacts to Vegetation
 Elliot Creek Storm Damage Project
 EA 0J201, SAN-1-Post Mile 0.01 - 0.3
 San Mateo County, California





LEGEND

- Project Footprint
- Biological Study Area (BSA)

Soil Map Unit

- Cf - Coastal beaches
- CmE2 - Colma sandy loam, steep, eroded
- Lmb - Lockwood loam, gently sloping
- SaF2 - Santa Lucia loam, very steep, eroded
- Ta - Terrace escarpments
- TeD2 - Tierra loam, moderately steep, eroded

Source of Map:
 Natural Resources Conservation Service
 Web Soil Survey
 Soil Survey Area: San Mateo Area, California
 Survey Area Data: Version 10, Sep 12, 2016

Service Layer Credits:
 Source: Esri, DigitalGlobe, GeoEye, Earthstar Geographics, CNES/Airbus DS, USDA, USGS, AeroGRID, IGN, and the GIS User Community
 Content may not reflect National Geographic's current map policy. Sources: National Geographic, Esri, DeLorme, HERE, UNEP-WCMC, USGS, NASA, ESA, METI, NRCAN, GEBCO, NOAA, increment P Corp.

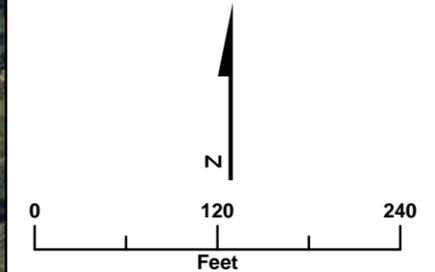

FIGURE 3-2
Soil Types Within the BSA
 Elliot Creek Storm Damage Project
 EA 0J201, SAN-1-Post Mile 0.01 - 0.3
 San Mateo County, California

very dark brown (10YR 2/2) shaley loam. The mapped soil in this location is not listed as hydric (NRCS 2017b). It is a well-drained soil with low to high runoff and moderately slow permeability. Associated vegetation includes annual grasses, forbs, scattered oak, and brush (NRCS 2003).

The Santa Lucia series consists of moderately deep, well-drained soils that formed in material weathered from white shale, containing some ash, and some siliceous and diatomaceous material. Santa Lucia soils are on uplands and have slopes of 2 to 75 percent. In a typical profile, the soil at the surface is a moderately acidic black (10YR 2/1) shaley light clay loam to a depth of 17 inches. From 17 to 24 inches the soil is a strongly acidic black (10YR 2/1) very shaley clay loam. These soils are well drained with very low to high runoff and with moderate permeability. The mapped soil in the location is not listed as hydric (NRCS 2017b). These soils occur in areas outside of the eroding bluff and road slip-out. Bedrock is only 24 to 28 inches deep in this soil type (NRCS 2013). There will be no digging in areas of Santa Lucia loam.

3.2.1.3 CLIMATE AND HYDROLOGY

The region has a coastal Mediterranean climate, with dry, mild summers and cool moist winters with an average of 3.9 inches of rain in the winter. The area experiences an average high of 78 degrees Fahrenheit (°F) in the hottest month and an average low of 45 °F in the coldest month. About 80 percent of annual rainfall occurs from October to April, ranging from 1 inch to 4.3 inches. Amounts less than 1 inch occur from May to September (Meteoblue weather 2017).

No wetlands or waters were observed within the BSA. There is an existing down drain within the Project footprint.

All natural hydrologic features occurring near the Project footprint are within the Gazos Creek-Frontal Ano Nuevo Bay Watershed (Hydrologic Unit Code: 180500060303).

3.2.2 Biological Conditions

The predominant natural plant communities in the Project region (within the Santa Cruz Mountain subregion) are Redwood series (*Sequoia sempervirens*) and Douglas-fir – tanoak series. Coast live oak series is common on the northeast side of the mountains. California oatgrass series and coyote brush series are common adjacent to the coast, and yellow bush lupine series is present on stabilized dunes. Chamise series and Manzanita shrublands are common in shallow soils and on south-facing slopes (Miles and Goudey 1997).

This region supports grasses, grass-oak and shrub vegetation. Naturalized annuals, including soft chess (*Bromus hordeaceus*), bromes, fescues, wild oats, filaree (*Erodium cicutarium*), and burclover (*Medicago polymorpha*), characterize the open and oak woodlands. Blue oak (*Quercus douglasii*), valley oak (*Quercus lobata*), and canyon live oak (*Quercus chrysolepis*) are the dominant trees. California sagebrush (*Artemisia californica*), coyote brush (*Baccharis pilularis*), chamise (*Adenostoma fasciculatum*), manzanitas, ceanothus, and scrub oak (*Quercus ilicifolia*) are the major brush species. Forest of Douglas-fir (*Pseudotsuga menziesii*), madrone (*Arbutus menziesii*), grand fir (*Abies grandis*), tanoak (*Notholithocarpus densiflorus*), and big leaf maples (*Acer macrophyllum*) and a few remnant stands of redwood trees are along the west side of the Coast Range. Stands of ponderosa pine (*Pinus ponderosa*) with madrone, black oak, canyon live oak, California buckeye (*Aesculus californica*), manzanita, and ceanothus are on the drier sites (NRCS 2003).

Some of the major wildlife species in this area are black-tailed deer (*Odocoileus hemionus*), feral pig (*Sus scrofa*), turkey (*Meleagris gallopavo intermedia*), blue grouse (*Dendragapus obscurus*), valley quail (*Callipepla californica*), and band-tailed pigeon (*Patagioenas fasciata*). The species of fish in the area include trout (*Oncorhynchus mykiss*), largemouth bass (*Micropterus salmoides*), bluegill (*Lepomis macrochirus*), minnow (*Cyprinidae*), stickleback (*Gasterosteidae*), channel catfish (*Ictalurus punctatus*), bullhead (*Ictalurus*), carp (*Cyprinidae*), sculpin (*Cottoidea*), salmon (*Salmonidae*), and crappie (*Pomoxis*) (USDA 2006).

3.2.2.1 VEGETATION TYPES

Vegetation found within the BSA includes four types that reflect human disturbance (developed bare ground, developed roadway, pasture/grazing land, and agricultural areas) and three natural vegetation types (*Pinus radiata* forest alliance [Monterey pine forest]/various riparian-associated alliances, coastal bluff scrub [*Baccharis pilularis*] – *Toxicodendron diversilobum* shrubland alliance [coyote brush – poison oak scrub]), and *Carpobrotus edulis* herbaceous semi-natural alliance (ice plant mats), shown on Figure 3-1. Common species found in disturbed areas include invasive non-natives such as ice plant (*Carpobrotus edulis*), poison hemlock (*Conium maculatum*), and wild oat (*Avena fatua*). Even though Elliot Creek runs through the site, riparian vegetation consists of only low-growing plants such as poison oak (*Toxicodendron diversilobum*) and California blackberry (*Rubrus ursinus*), while most vegetation is coastal scrub, Monterey pine forest, and ruderal non-native plants. Definitions of the natural vegetation types found within the BSA are presented below, as described in the Manual of California Vegetation (Sawyer et al. 2009).

Riparian/Monterey Pine

The Monterey pine forest alliance includes species such as big leaf maple (*Acer macrophyllum*), white alder (*Alnus rhombifolia*), madrone (*Arbutus menziesii*), Monterey cypress (*Cupressus macrocarpa*), knobcone pine (*Pinus attenuata*), coast live oak (*Quercus agrifolia*), arroyo willow (*Salix lasiolepis*), and tan oak (*Notholithocarpus densiflorus*) and is associated with nearby riparian vegetation as well. Understory vegetation is dense, consisting of annual grasses and both annual and perennial forbs such as poison oak.

There are also multiple riparian series within the BSA, such as *Argentina egedii* (*Potentilla anserine* ssp. *Pacifica*) herbaceous alliance (Pacific silverweed marsh) found at the mouth of Elliot Creek and *Umbellularia californica*/*Toxicodendron diversilobum* forest alliance (California bay – poison oak) found east of the culvert. The Pacific silverweed alliance is found where Elliot Creek meets the Pacific Ocean, below the Project footprint. Some common plant species found in this habitat are common threesquare (*Schoenoplectus pungens*), curly dock (*Rumex crispus*), and seep monkey flower (*Mimulus guttatus*). Duckweed (*Lemna* ssp.) is also found here. The California Bay forest is found above the Project footprint and is commonly codominant with many species, including but not limited to big leaf, California buckeye (*Aesculus californica*), white alder (*Alnus rhombifolia*), red alder (*Alnus rubrus*), madrone, California walnut (*Juglans californica*), and tan oak.

Coastal Bluff Scrub

Coyote brush is dominant with poison oak and potentially codominant in the shrub canopy with numerous other shrub species, including California sage (*Artemisia californica*), California blackberry, and California toyon (*Heteromeles arbutifolia*). Understory vegetation consists of annual grasses and forbs dominated by one or more naturalized annual species such as wild oat (*Avena barbata*), foxtail barley (*Hordeum murinum*), soft chess (*Bromus hordeaceus*), rip-gut brome (*Bromus diandrus*), false brome (*Brachypodium distachyon*), and Italian ryegrass (*Festuca perennis*). These grassland types generally correspond to the *Avena* (*barbata*, *fatua*) semi-natural herbaceous stands (wild oats grasslands), *Bromus* (*diandrus*, *hordeaceus*) - *Brachypodium distachyon* semi-natural herbaceous stands (annual brome grasslands), and *Lolium perenne* semi-natural herbaceous stands (perennial ryegrass fields), as described in the Manual of California Vegetation (Sawyer et al. 2009). Common associated wildflowers include buckwheat (*Trifolium angustifolium*), vetch (*Vicia villosa*), Italian thistle (*Carduus pycnocephalus*), black mustard (*Brassica nigra*), and fiddle dock (*Rumex crispus*).

Non-natives/Ice Plant

Carpobrotus chilensis, *Carpobrotus edulus*, or other ice plant taxa are dominant in the herbaceous layer. Emergent trees and shrubs may be present at low cover (Sawyer et al. 2009).

3.3 Regional Species and Habitats of Concern

Tables 3-1 and 3-2 identify the special-status plant and wildlife species, respectively, included on the CNDDDB, USFWS, and CNPS lists that have the potential to occur in the BSA based on the USGS 7.5-minute quadrangle map that encompasses the BSA (Ano Nuevo) and the five adjacent quadrangles (Pigeon Point, Franklin Point, Big Basin, Davenport, and Santa Cruz). See Figures 2-1 and 2-2 for locations of CNDDDB occurrences of these species within a 5-mile radius of the BSA. A complete list of species from the database searches is provided in Appendix C.

Special-status plant species identified in Table 3-1 and in Appendix C were evaluated for their potential to occur within the BSA. These plant species either were eliminated from further consideration based on the absence of suitable habitat characteristics within the Project footprint and/or were not found during plant surveys. As mentioned in the Wetland Plant Memo (see Appendix D), no federally listed or rare plants were identified within the BSA.

Special-status wildlife species listed in Table 3-2 were evaluated for their potential to occur within the BSA and Project footprint. A species was determined absent from the Project footprint if: (1) no suitable habitat was identified in the Project footprint; and (2) the Project footprint was found to be outside of the species' range.

Special-status species that have the potential or are known to occur in the BSA, based on the field surveys and database reviews, are given further consideration in Chapter 4. These include the following individual species:

- California red-legged frog (CRLF) (*Rana draytonii*), FT
- San Francisco garter snake (SFGS) (*Thamnophis sirtalis tetrataenia*), FE
- Marbled murrelet (*Brachyramphus marmoratus*), FT
- San Francisco dusky-footed woodrat (*Neotoma fuscipes annectens*), California species of special concern
- Western snowy plover (*Charadrius nivosus nivosus*), FT
- Monterey pine (*Pinus radiata*), 1B.1

Table 3-1 Special-Status Plant Species with Potential to Occur in the Biological Study Area

Scientific Name	Common Name	Rare Plant Rank ^a	CESA List ^b	FESA List ^b	Elevation Low (meters)	Elevation High (meters)	General Habitat ^c	Micro-Habitat	Potential to Occur	Potential Effects to Federally Listed Species
<i>Agrostis blasdalei</i>	Blasdales's bend grass	1B.2	-	-	0	150	Coastal bluff scrub, coastal dunes, coastal prairie.	Historical occurrences need field surveys.	Low. Suitable habitat is not found within the BSA and species was not observed during botanical surveys. Nearest occurrence found approximately 4 miles to the south of the BSA (CDFW 2017).	-
<i>Amsinckia lunaris</i>	Bent-flowered fiddleneck	1B.2	-	-	3	500	Coastal bluff scrub, Cismontane woodland, and valley and foothill grassland.	Many collections old; current status information needed.	Low. No suitable habitat present and species was not observed during botanical surveys. Nearest occurrences are reported approximately 4 miles south of the BSA (last seen in 1980) (CDFW 2017).	-
<i>Arctostaphylos andersonii</i>	Anderson's manzanita	1B.2	-	-	60	760	Broadleafed upland forest, chaparral, north coast coniferous forest.	Openings, edges; confused with other species merged with it as varieties.	Low. Suitable habitat is present in BSA and species was not observed during botanical surveys. Nearest occurrence is approximately 4 miles east of BSA (CDFW 2017).	-
<i>Arctostaphylos glutinosa</i>	Schreiber's manzanita	1B.1	-	-	170	685	Closed-cone coniferous forest, chaparral.	Diatomaceous shale; known from fewer than ten occurrences.	Low. Suitable habitat is present in BSA and species was not observed during botanical surveys. Nearest occurrence is approximately 2 miles east of the BSA (CDFW 2017).	-
<i>Arctostaphylos ohloneana</i>	Ohlone manzanita	1B.1	-	-	450	530	Closed-cone coniferous forest, coastal scrub.	Siliceous shale; known from fewer than 5 occurrences.	Low. Suitable habitat is not present and species was not observed during botanical surveys. Nearest occurrences is within approximately 4 miles of the BSA (CDFW 2017).	-
<i>Arctostaphylos regismontana</i>	Kings Mountain mananita	1B.2	-	-	305	730	Broadleafed upland forest, chaparral, north coast coniferous forest.	Granitic or sandstone.	Low. Suitable habitat not present species was not observed during botanical surveys. Nearest occurrence is approximately 7 miles east of the BSA (CDFW 2017).	-
<i>Arctostaphylos silvicola</i>	Bonny Doon manzanita, silverleaf manzanita	1B.2	-	-	120	600	Closed-cone coniferous forest, chaparral, lower montane coniferous forest.	Inland marine sands.	Low. Suitable habitat not present and species was not observed during botanical surveys. No occurrences are reported within 5 miles of the BSA (CDFW 2017).	-
<i>Arenaria paludicola</i>	marsh sandwort	1B.1	E	E	3	170	Marshes and swamps (freshwater or brackish).	Sandy, openings; known from only two natural occurrences in Black Lake canyon and Oso Flaco Lake.	Low. Suitable habitat is not present and species was not observed during botanical surveys (CDFW 2017).	No Effect
<i>Astragalus pycnostachyus</i> var. <i>pycnostachyus</i>	coastal marsh milk-vetch	1B.2	-	-	0	30	Coastal dunes (mesic), coastal scrub, marshes and swamps (coastal salt, streamsides).	Presumed extirpated in Franklin Point quad.	Low. Species was not observed during botanical surveys and no occurrences are reported within 5 miles of the BSA (CDFW 2017).	-
<i>California macrophylla</i>	round-leaved filaree	1B.2	-	-	15	1200	Cismontane woodland, valley and foothill grassland.	Vertic clay.	Low. Suitable habitat is not present and species was not observed during botanical surveys. No occurrences are reported within 5 miles of the BSA (CDFW 2017).	No Effect

Table 3-1 Special-Status Plant Species with Potential to Occur in the Biological Study Area

Scientific Name	Common Name	Rare Plant Rank ^a	CESA List ^b	FESA List ^b	Elevation Low (meters)	Elevation High (meters)	General Habitat ^c	Micro-Habitat	Potential to Occur	Potential Effects to Federally Listed Species
<i>Calyptridium parryi</i> var. <i>hesseae</i>	Santa Cruz Mountains pussypaws	1B.1	-	-	305	1530	Chaparral, cismontane woodland.	Sandy or gravelly, openings; known from fewer than twenty occurrences.	Low. Suitable habitat is not present and outside of species known range. One occurrence reported within 5 miles of the BSA (CDFW 2017).	-
<i>Chorizanthe pungens</i> var. <i>hartwegiana</i>	Ben Lomond spineflower	1B.1	-	E	90	610	Lower montane coniferous forest (maritime ponderosa pine sandhills).	Known only from sandhill parklands in the Santa Cruz Mountains.	Low. Suitable habitat is not present and outside the species known range within sandhill communities within the Santa Cruz Mountains. Nearest occurrence is 8 miles away in the Davenport quad (CDFW 2017, Calflora 2016).	No Effect
<i>Chorizanthe robusta</i> var. <i>hartwegii</i>	Scotts Valley spineflower	1B.1	-	E	230	245	Meadows and seeps (sandy), valley and foothill grassland (mudstone and Purisima outcrops).	Known only from Scotts Valley.	Low. Suitable habitat is not present and is outside of species known range. No occurrences are reported within 10 miles of the BSA (CDFW 2017).	No Effect
<i>Chorizanthe robusta</i> var. <i>robusta</i>	Robust spineflower	1B.1	-	E	3	300	Chaparral (maritime), Cismontane woodland (openings), coastal dunes and coastal scrub.	Sandy or gravelly soils; most populations extirpated, and known from only six extended occurrences.	Low. Suitable habitat is not present and is outside of species known range. No occurrences are reported within 5 miles of the BSA (CDFW 2017).	No Effect
<i>Cirsium andrewsii</i>	Franciscan thistle	1B.2	-	-	0	150	Broadleaved upland forest, coastal bluff scrub, coastal prairie scrub, coastal scrub.	Mesic, sometimes serpentinite.	Low. Species is considered extirpated in area and was not observed during botanical surveys (CDFW 2017).	-
<i>Collinsia multicolor</i>	San Francisco collinsia	1B.2	-	-	30	250	Closed-cone coniferous forest, coastal scrub.	Sometimes serpentinite.	Low. Suitable habitat present but not observed during botanical surveys. Nearest occurrence found approximately 2 miles south of BSA (CDFW 2017).	-
<i>Dacryophyllum falcifolium</i>	tear drop moss	1B.3	-	-	50	275	North coast coniferous forest.	Carbonate/ limestone substrates.	Low. Suitable habitat not present. Nearest record approximately 15 miles southeast (CDFW 2017).	-
<i>Erysimum ammophilum</i>	sand-loving wallflower	1B.2	-	-	0	60	Chaparral (maritime), coastal dunes, coastal scrub.	Sandy, openings.	Low. Suitable habitat not present and species was not observed during botanical surveys. Nearest record approximately 1 mile north of BSA (CDFW 2017).	-
<i>Erysimum menziesii</i>	Menzies' wallflower	1B.1	E	E	0	35	Coastal dunes.	Known from 16 extant occurrences.	Low. Suitable habitat is not present and not observed during botanical surveys. No occurrences are reported within 10 miles of the BSA (CDFW 2017).	No Effect
<i>Erysimum teretifolium</i>	Santa Cruz wallflower	1B.1	E	E	120	610	Chaparral, lower montane coniferous forest.	Inland marine sands.	Low. No suitable habitat within the Project footprint. Nearest occurrence is 9 miles east in Davenport quad (CDFW 2017, Calflora 2016).	No Effect

Table 3-1 Special-Status Plant Species with Potential to Occur in the Biological Study Area

Scientific Name	Common Name	Rare Plant Rank ^a	CESA List ^b	FESA List ^b	Elevation Low (meters)	Elevation High (meters)	General Habitat ^c	Micro-Habitat	Potential to Occur	Potential Effects to Federally Listed Species
<i>Fissidens pauperculus</i>	minute pocket moss	1B.2	-	-	10	1024	North coast coniferous forest.	Damp coastal soil.	Low. Suitable habitat not present and was not observed during botanical surveys. No occurrences within 5 miles of BSA (CDFW 2017).	-
<i>Fritillaria liliacea</i>	Fragrant fritillary	1B.2	-	-	3	140	Cismontane woodland, coastal prairie, and coastal scrub; valley and foothill grassland.	Often serpentinite soils.	Low. Suitable habitat not present and species was not observed during botanical surveys. One occurrence approximately 3 miles north of BSA (CDFW 2017).	-
<i>Grimmia torenii</i>	Toren's grimmia	1B.3	-	-	325	1,160	Chaparral, cismontane woodland, lower montane coniferous forest.	Openings, rocky, boulder and rock walls, carbonate, volcanic.	Low. Suitable habitat not present and outside of species' range.	-
<i>Grimmia vaginulata</i>	vaginulate grimmia	1B.1	-	-	N/A	N/A	Chaparral (openings).	rocky, boulder and rock walls, carbonate; known from 2 occurrences.	Low. Suitable habitat not present and species was not observed during botanical surveys.	-
<i>Hesperevax sparsiflora</i> var. <i>brevifolia</i>	short-leaved evax	1B.2	-	-	0	215	Coastal bluff scrub (sandy), coastal dunes, coastal prairie.	Sandy bluffs and flats.	Low. Suitable habitat is not present and species was not observed during botanical surveys. Nearest occurrence approximately 8 miles east of BSA (CDFW 2017).	-
<i>Hesperocypris abramsiana</i> var. <i>abramsiana</i>	Santa Cruz cypress	1B.2	T	E	280	800	Closed-cone coniferous forest, chaparral, lower montane coniferous forest.	Sandstone or granitic; known only from the Santa Cruz Mountains.	Low. No suitable habitat within the Project footprint. Nearest occurrence is over 5 miles away in Davenport quad (CDFW 2017, Calflora 2016).	No Effect
<i>Hesperocypris abramsiana</i> var. <i>butanoensis</i>	Butano Ridge cypress	1B.2	T	E	400	490	Closed-cone coniferous forest, chaparral, lower montane coniferous forest.	Sandstone; known only from Butano Ridge of the Santa Cruz Mountains.	Low. Suitable habitat is not present and is outside of species known range. No occurrences are reported within 5 miles of the BSA (CDFW 2017).	No Effect
<i>Holocarpha macradenia</i>	Santa Cruz tarplant	1B.1	T	E	10	220	Coastal prairie, coastal scrub, valley and foothill grassland.	Often clay, sandy.	Low. Suitable habitat is not present and species was not observed during botanical surveys. No occurrences are reported within 10 miles of the BSA (CDFW 2017).	No Effect
<i>Horkelia cuneata</i> var. <i>sericea</i>	Kellogg's horkelia	1B.1	-	-	10	200	Closed-cone coniferous forest, chaparral (maritime), coastal dunes, coastal scrub.	Sandy or gravelly, openings.	Low. Suitable habitat is present in BSA and nearest occurrence is 3 miles south of BSA (CDFW 2017). No observations were made during botanical surveys.	-
<i>Horkelia marinensis</i>	Point Reyes horkelia	1B.2	-	-	5	755	Coastal dunes, coastal prairies, coastal scrub.	Sandy.	Low. Suitable habitat is present within BSA but was not observed during botanical surveys. Nearest occurrence is found approximately 2 miles south of the BSA (CDFW 2017).	-

Table 3-1 Special-Status Plant Species with Potential to Occur in the Biological Study Area

Scientific Name	Common Name	Rare Plant Rank ^a	CESA List ^b	FESA List ^b	Elevation Low (meters)	Elevation High (meters)	General Habitat ^c	Micro-Habitat	Potential to Occur	Potential Effects to Federally Listed Species
<i>Lasthenia californica</i> ssp. <i>macrantha</i>	perennial goldfields	1B.2	-	-	5	520	Coastal bluff scrub, coastal dunes, coastal scrub.	N/A	Low. Suitable habitat is present but species was not observed during botanical surveys. No occurrences are reported within 5 miles of the BSA (CDFW 2017).	-
<i>Leptosiphon rosaceus</i>	rose leptosiphon	1B.1	-	-	0	100	Coastal bluff scrub.	N/A	Low. Suitable habitat is present but was not observed during botanical surveys. No occurrences are reported within 10 miles of the BSA (CDFW 2017).	-
<i>Limnanthes douglasii</i> ssp. <i>sulphurea</i>	Point Reyes meadow-foam	1B.2	E	-	0	140	Coastal prairie, meadows and seeps (mesic), marshes and swamps (freshwater), vernal pools.	Known from fewer than 15 occurrences.	Low. Suitable habitat is present but species was not observed during botanical surveys. Nearest occurrence is approximately 8 miles north of the BSA (CDFW 2017).	-
<i>Malacothamnus arcuatus</i>	arcuate bush-mallow	1B.2	-	-	15	355	Chaparral, cismontane woodland.		Low. Suitable habitat not present and was not observed during botanical surveys. No occurrences within 5 miles of BSA (CDFW 2017).	-
<i>Microseris paludosa</i>	marsh microseris	1B.2	-	-	5	.355	Closed-cone coniferous forest, cismontane woodland, coastal scrub, valley and foothill grassland.	similar to <i>M. lacinata</i> spp. <i>leptosepala</i> .	Low. Suitable habitat present within BSA but was not observed during botanical surveys. Nearest occurrence is 3 miles south of BSA (CDFW 2017).	-
<i>Monolopia gracilens</i>	woodland woollythreads	1B.2	-	-	100	1,200	Broadleafed upland forest (openings), chaparral (openings), cismontane woodland, north coast coniferous forest (openings), valley and foothill grassland.	Serpentine.	Low. Suitable habitat not present and was not observed during botanical surveys. No occurrences with 10 miles of BSA (CDFW 2017).	-
<i>Orthotrichum kellmanii</i>	Kellman's bristle moss	1B.2	-	-	343	685	Chaparral, cismontane woodland.	Sandstone, carbonate.	Low. Suitable habitat not present and was not observed during botanical surveys. No occurrences with 5 miles of BSA (CDFW 2017).	-
<i>Pedicularis dudleyi</i>	Dudley's lousewort	1B.2	R	-	60	900	Chaparral (maritime), cismontane woodland, north coast coniferous forest, valley and foothill grassland.	Known from 11 occurrences.	Low. Suitable habitat not present and was not observed during botanical surveys. No occurrences with 5 miles of BSA (CDFW 2017).	-
<i>Penstemon rattanii</i> var. <i>kleei</i>	Santa Cruz Mountains beardtongue	1B.2	-	-	400	1,100	Chaparral, lower montane coniferous forest, north coast coniferous forest.	Known from fewer than 10 occurrences.	Low. Suitable habitat is not present and is outside of species' known range. Nearest occurrence is approximately 4 miles east of the BSA (CDFW 2017).	-
<i>Pentachaeta bellidiflora</i>	white-rayed pentachaeta	1B.1	E	E	35	620	Cismontane woodland, valley and foothill grassland.	Often serpentine.	Low. Suitable habitat is not present and is outside of species' known range. The closest CNDDB-documented occurrence is 3.2 miles east of site. Three other occurrences are at least 5 miles away and are possibly extirpated (CDFW 2017, Calflora 2016).	No Effect

Table 3-1 Special-Status Plant Species with Potential to Occur in the Biological Study Area

Scientific Name	Common Name	Rare Plant Rank ^a	CESA List ^b	FESA List ^b	Elevation Low (meters)	Elevation High (meters)	General Habitat ^c	Micro-Habitat	Potential to Occur	Potential Effects to Federally Listed Species
<i>Pinus radiata</i>	Monterey pine	1B.1	-	-	25	185	Closed-cone coniferous forest, cismontane woodland.	Only three native stands in California, at Ano Nuevo, Cambria, and the Monterey Peninsula: introduced in many areas.	Present. Suitable habitat is present in BSA. Project falls within the current native range of the species, and species was observed during botanical surveys. BSA is located within an occurrence (#5) of this species (CDFW 2017). There is one Monterey pine located adjacent to the permanent impact area. See Section 4.3.1.2 for proposed measures to protect this tree.	-
<i>Piperia candida</i>	white-flowered rein orchid	1B.2	-	-	30	1,310	Broadleafed upland forest, lower montane coniferous forest, North coast coniferous forest.	Sometimes serpentinite; difficult to determine rarity as some populations rarely flower, populations often have small numbers.	Low. Suitable habitat not present and was not observed during botanical surveys. Nearest occurrence is 6 miles east of the BSA (CDFW 2017).	-
<i>Plagiobothrys chorisianus</i> var. <i>chorisianus</i>	choris' popcornflower	1B.2	-	-	3	160	Chaparral, coastal prairie, coastal scrub.	Mesic; taxonomic work needed, intergrades with var. <i>hickmanii</i> and differences may be environmentally induced.	Low. Suitable habitat not present and was not observed during botanical surveys. Nearest occurrence is 3 miles north of the BSA (CDFW 2017).	-
<i>Plagiobothrys diffusus</i>	San Francisco popcornflower	1B.1	E	-	60	360	Coastal prairie, valley and foothill grassland.	Known from 15 occurrences.	Low. Suitable habitat not present and was not observed during botanical surveys. Nearest occurrences are 3 miles north and south of the BSA (CDFW 2017).	-
<i>Polygonum hickmanii</i>	Scotts Valley polygonum	1B.1	E	E	210	250	Valley and foothill grassland (mudstone and sandstone).	Known only from Scotts Valley; fewer than 3,500 individuals as of 1998.	Low. Suitable habitat not present and was not observed during botanical surveys. Nearest occurrences are 16 miles southeast of the BSA (CDFW 2017).	No Effect
<i>Rosa pinetorum</i>	pine rose	1B.2	-	-	2	945	Closed-cone coniferous forest, cismontane woodland.	Possible hybrid of <i>R. spithamea</i> , <i>R. gymnocarpa</i> , or others.	Low. Suitable habitat present but was not observed during botanical surveys. Nearest occurrence is approximately 1.5 miles south of the BSA (CDFW 2017).	-
<i>Senecio aphanactis</i>	Chaparral ragwort	2B.2	-	-	15	800	Chaparral, cismontane woodland, coastal scrub.	Sometimes alkaline.	Low. Suitable habitat present within BSA but not observed during botanical surveys. Nearest occurrence is 10 miles south of BSA (CDFW 2017).	-
<i>Silene verecunda</i> ssp. <i>verecunda</i>	San Francisco campion	1B.2	-	-	30	645	Coastal bluff scrub, chaparral, coastal prairie, coastal scrub, valley and foothill grassland	Sandy	Low. Suitable habitat present within BSA but was not observed during botanical surveys. Nearest occurrence is 2 miles south of BSA (CDFW 2017).	-
<i>Stebbinsoseris decipiens</i>	Santa Cruz microseris	1B.2	-	-	10	500	Broadleafed upland forest, closed-coned coniferous forest, chaparral, coastal prairie, coastal scrub, valley and foothill grassland.	Open areas, sometimes serpentinite.	Low. Suitable habitat present within BSA but was not observed during botanical surveys. Nearest occurrence is 1 mile south of BSA (CDFW 2017).	-

Table 3-1 Special-Status Plant Species with Potential to Occur in the Biological Study Area

Scientific Name	Common Name	Rare Plant Rank ^a	CESA List ^b	FESA List ^b	Elevation Low (meters)	Elevation High (meters)	General Habitat ^c	Micro-Habitat	Potential to Occur	Potential Effects to Federally Listed Species
<i>Stuckenia filiformis</i> ssp. <i>alpina</i>	slender-leaved pondweed	2B.2	-	-	300	2,150	Marshes swamps (assorted shallow freshwater).	To be expected in the San Joaquin Valley, San Francisco Bay area and the central high Sierra Nevada.	Low. Suitable habitat is not present and was not observed during botanical surveys. Nearest occurrence is approximately 2 miles north of the BSA (CDFW 2017).	-
<i>Trifolium buckwestiorum</i>	Santa Cruz clover	1B.1	-	-	105	610	Broadleafed upland forest, cismontane woodland, coastal prairie.	Gravelly, margins.	Low. Suitable habitat is not present and was not observed during botanical surveys. Nearest occurrence is approximately 3 miles south of the BSA (CDFW 2017).	-

^a California Native Plant Society Rankings:

1A = Plants presumed extirpated in California and either rare or extinct elsewhere

1B = Plants rare, threatened, or endangered in California and elsewhere

.1 = Seriously threatened in California (over 80 percent of occurrences threatened/high degree and immediacy of threat)

.2 = Moderately threatened in California (20 to 80 percent of occurrences threatened/moderate degree and immediacy of threat)

^b CESA and FESA Listings:

E = Endangered

T = Threatened

^c California Natural Diversity Database (CDFW 2017).

Sources: Inventory of Rare and Endangered Plants (CNPS 2017); California Natural Diversity Database (CDFW 2017); and Information for Planning and Conservation (USFWS 2017).

Table 3-2 Special-Status Animal Species with Potential to Occur in the Biological Study Area

Scientific Name	Common Name	USFWS ^a /CDFW ^b	General Habitat	Micro-Habitat	Potential to Occur	Potential Effects to Federally Listed Species
Fishes						
<i>Eucyclogobius newberryi</i>	tidewater goby	SSC	Lagoons, estuaries, backwater marshes, and freshwater tributaries to estuarine environments that closely correspond to major stream drainages.	They generally select habitat in the upper estuary, usually within the freshwater-saltwater interface. Typically found in salinities of less than 12 parts per thousand such as in the upper edge of tidal bays or in coastal lagoons formed at the mouths of coastal rivers.	None. No potential to occur in Project footprint. Fresh water with high flow is present and the mouth of Elliot Creek is a waterfall about 75 feet high. Only two CNDDDB-documented occurrences within a 5-mile radius. Closest occurrence is 1.4 miles south in Waddell Creek, and 4.77 miles south in Scott Creek (CDFW 2017).	-
<i>Hypomesus transpacificus</i>	Delta smelt	FT	Delta smelt require specific environmental conditions (freshwater flow, water quality) and habitat types (shallow open waters) within estuary for migration, spawning, egg incubation, rearing, and larval and juvenile transport from spawning to rearing habitats.	They can tolerate a wide range of salinities but are rarely found in water with more than 10 to 12 parts per thousand salinity.	None. Suitable habitat is not present within the BSA. The closest known occurrence is over 60 miles northeast of the BSA (CDFW 2017).	No Effect
<i>Oncorhynchus kisutch</i>	Coho salmon-Central California Coast ESU/critical habitat	FE/SE	Constructs nests in cobble substrates of cool streams that reach the ocean and contain shallow, partly shaded pools, riffles, and runs.	Optimal growth occurs at 12 to 14°C and Coho salmon fail to survive in streams where the temperature exceeds 22 to 25°C for extended periods of time. Juvenile Coho salmon prefer pools and usually begin to favor higher stream velocities as they get older, occupying the midstream and stream margin areas.	None. Suitable habitat is not present within the BSA. The closest known occurrence is approximately 2 miles south of BSA in Waddell Creek, which does have suitable habitat (CDFW 2017). There is no way to enter Elliot Creek from the ocean and no connectivity from other streams. The mouth of Elliot Creek is a waterfall about 75 feet high.	No Effect
<i>Oncorhynchus mykiss irideus</i>	Steelhead – Central California Coast DPS	AFS_T	From Russian River, south to Soquel Creek and to, but not including, Pajaro River.	Also San Francisco and San Pablo Bay basins.	None. Suitable habitat is not present within the BSA. The closest known occurrence is approximately 2 miles south of the BSA in Waddell Creek, which does have suitable habitat (CDFW 2017). There is no way to enter Elliot Creek from the ocean and no connectivity from other streams. The mouth of Elliot Creek is a waterfall about 75 feet high. Final Designated Critical Habitat is north and south of the project site, with no connectivity to Elliot Creek.	No Effect
<i>Spirinchus thaleichthys</i>	longfin smelt	SSC	Longfin smelt are pelagic, estuarine-anadromous species that can tolerate a wide range of salinities.	Most of their lifecycle is completed in brackish to marine waters, with most post-larval fish in the San Francisco Bay-Delta DPS found in salinities from 15 to 30 psu.	None. Suitable habitat is not present within the BSA. The closest known occurrence is approximately 2 miles south of BSA in Waddell Creek, which does have suitable habitat (CDFW 2017).	-
Amphibians						
<i>Ambystoma californiense</i>	California tiger salamander	FE/ST	Uses ground-squirrel burrows and vernal pools or other seasonal water sources for breeding.	Populations in Sonoma County, need underground refuges.	Low. No breeding or estivation habitat present in the BSA. No occurrences within 10 miles of the BSA (CDFS 2017).	No Effect
<i>Aneides niger</i>	Santa Cruz black salamander	SSC	Occurs in mixed deciduous woodland, coniferous forests, and coastal grasslands.	Often found under rocks near streams, in talus, under damp logs and other objects.	Low. Suitable habitat is not present within Project footprint. The closest known occurrence is approximately 2 miles south of BSA in Waddell Creek, which does have suitable habitat (CDFW 2017).	-
<i>Dicamptodon ensatus</i>	California giant salamander	SSC	Adults are found in humid forests under rocks and logs. Larvae usually inhabit clear, cold streams, but are also found in mountain lakes and ponds	Prefer fast- to slow-moving water and cover for brooding eggs.	Low. Suitable habitat is not present within Project footprint. Three occurrences are found within 5 miles of the BSA (CDFW 2017).	-

Table 3-2 Special-Status Animal Species with Potential to Occur in the Biological Study Area

Scientific Name	Common Name	USFWS ^a /CDFW ^b	General Habitat	Micro-Habitat	Potential to Occur	Potential Effects to Federally Listed Species
<i>Rana draytonii</i>	California red-legged frog	FT/SSC	Lowlands and foothills in or near permanent sources of deep water with dense, shrubby or emergent riparian vegetation.	Requires 11 to 20 weeks of permanent water for larval development, and must have access to estivation habitat.	Moderate. Appropriate aquatic and upland habitat are present within the BSA. Appropriate upland dispersal habitat is present within the Project footprint and within dispersal distance of known occurrences. Eighteen occurrences of CRLF were within 5 miles of the BSA (CDFW 2017). Closest CRLF documented is 1 mile north in a pond on the same side of the road. Critical Habitat encompasses the Project footprint (CDFW 2017).	May affect, and is likely to adversely affect.
Reptiles						
<i>Chelonia mydas</i>	green sea turtle	FT	Green turtles are highly migratory and use a wide range of separated localities and habitats.	Common in shallow tropical and subtropical waters, oceanic zones, and neritic zones including sea grass beds and coastline beaches	None. Suitable habitat is not present in the BSA.	No Effect
<i>Emys marmorata</i>	western pond turtle	SSC	A thoroughly aquatic turtle of ponds, marshes, rivers, streams, and irrigation ditches, usually with aquatic vegetation, below 6,000 feet elevation.	Need basking sites and suitable (sandy banks or grassy open fields) upland habitat up to 0.3 mile from water for egg laying.	Low. Water flow is seasonal and no basking or suitable upland habitat is present within the BSA. Nearest occurrence is 2 miles south of the BSA in Waddell Creek (CDFW 2017).	-
<i>Thamnophis sirtalis tetrataenia</i>	San Francisco gartersnake	FE/SE	Found in the vicinity of freshwater marshes, ponds, and slow-moving streams in San Mateo County and Santa Cruz County. Prefers dense cover and water depths of at least 1 foot.	May overwinter in upland areas away from water.	Moderate. Potential to occur onsite. Upland habitat is present onsite, and documented occurrence is only 0.5 mile north of site on opposite side of the road. Recent documentation (2015) of occurrence in pond just 0.9 mile north of site on the same side of the road. Many occurrences found 1.3 miles south near the entrance to Waddell Creek (CDFW 2017).	May affect, and is likely to adversely affect.
Birds						
<i>Agelaius tricolor</i>	tricolored blackbird	SSC	Freshwater marsh and wetlands. Highly colonial species, most numerous in Central Valley and vicinity. Largely endemic to California.	Requires open water, protected nesting substrate, and foraging area with insect prey within a few kilometers of the colony.	Low. No suitable habitat present within the BSA. Closest known CNDDDB occurrence of approximately 4 miles south of the BSA (CDFW 2017).	-
<i>Athene cunicularia</i>	burrowing owl	SSC	Open, dry annual or perennial grasslands, deserts, and scrublands characterized by low-growing vegetation.	Subterranean nester, dependent upon burrowing mammals, most notably, the California ground squirrel.	Low. No habitat present in the BSA. Closest known CNDDDB occurrence approximately 7 miles south of the BSA.	-
<i>Brachyramphus marmoratus</i>	marbled murrelet	FT	Breeds in coniferous forests near coasts, nesting on large horizontal branches high up in trees. Winters at sea.	Dense stands of tall conifers	Low. May occur as a fly-over en route to nesting sites because there is no suitable nesting habitat within the Project footprint. Critical habitat is outside of Project location. Closest documentation is 1.8 miles away. One CNDDDB-documented failed nest in 1997. Birds were detected in 1999 and 2001. Birds were seen in 1993 2.5 miles away in Big Basin. Other occurrences were 2.5 miles northeast in 1988, and 1.8 miles northeast and east.(CDFW 2017).	May affect, and is not likely to adversely affect.
<i>Charadrius alexandrinus nivosus</i>	western snowy plover	FT/SSC	Sandy beaches, salt pond levees, and shores of large alkali lakes.	Needs sandy, gravelly or friable soils for nesting.	Low. Habitat is not within the project BSA, but species may occur as a fly-over en route to nesting or feeding sites. There are three CNDDDB-documented occurrences within a 5-mile radius. The closest occurrence is 0.5 mile north of site (in 1978), with eight adults and two broods. The next nearest occurrence is 1.3 miles south at Waddell Creek. Critical Habitat is found 1.2 miles south of the site at Waddell Creek (CDFW 2017).	No Effect

Table 3-2 Special-Status Animal Species with Potential to Occur in the Biological Study Area

Scientific Name	Common Name	USFWS ^a /CDFW ^b	General Habitat	Micro-Habitat	Potential to Occur	Potential Effects to Federally Listed Species
<i>Cypseloides niger</i>	black swift	SCC	Black swifts are a near arctic-neotropical migrant bird species, breeding from Alaska to California, and Montana to Colorado.	Prefers forests with rivers and has been known to nest behind waterfalls, on wet cliffs, and in limestone caves.	Low. No suitable habitat in BSA or in vicinity of the Project footprint. Nearest occurrence is 2 miles north of the BSA (CDFW 2017).	-
<i>Empidonax traillii extimus</i>	southwestern willow flycatcher	FE	Found in relatively dense riparian tree and shrub communities associated with rivers, swamps, and other wetlands.	Usually occurs within the first 10 to 13 feet above ground and require at least 0.25 acre.	Low. No suitable habitat in BSA. Nearest occurrence is over 200 miles south of the BSA (CDFW 2017).	No Effect
<i>Geothlypis trichas sinuosa</i>	saltmarsh common yellowthroat	SSC	Woody swamps, brackish marshes, and freshwater marshes along the coast or San Francisco Bay region.	Prefer to occupy ecotones between moist and upland situations and can be found near seeps and swales.	Low. No suitable habitat in BSA. No occurrences are reported within 5 miles of the BSA (CDFW 2017).	-
<i>Laterallus jamaicensis coturniculus</i>	California black rail	ST	Found in tidal salt marshes of the northern San Francisco Bay region, primarily in San Pablo and Suisun Bays.	Occupies marshes with shallower water than other rallids and requires some tall vegetation to escape into.	Low. No suitable habitat in BSA or in vicinity of the Project footprint. Nearest occurrence is 2 miles south of the BSA (CDFW 2017).	-
<i>Phoebastria albatrus</i>	short-tailed albatross	FE	Breeds on rocky coastal offshore Pacific Rim islands.	Nests in sandy areas on islands. Spends nonbreeding season on open ocean.	None. No suitable habitat in BSA or in vicinity of the Project footprint.	No Effect
<i>Riparia</i>	bank swallow	ST	Found along soft banks or bluffs along rivers, streams, and coastal areas. They prefer eroding banks of low-gradient, meandering rivers and streams.	Known to forage near wetlands, grasslands, large bodies of water, agricultural areas, and open woodlands.	Low. No suitable habitat in Project footprint. Nearest occurrences are 1.5 miles north of the BSA (CDFW 2017).	-
<i>Sterna antillarum browni</i>	California least tern	FE/SE	Migratory in California; seacoasts, beaches, bays, estuaries, lagoons, lakes, and rivers.	Breeding on sandy or gravelly beaches and banks of rivers or lakes.	Low. Suitable habitat within the BSA but not within the Project footprint. Nearest occurrence is 26 miles north of the BSA (CDFW 2017).	No Effect
<i>Vireo bellii pusillus</i>	least Bell's vireo	FE	Found in riparian areas with dense tree or shrub vegetation.	Most commonly found in willow riparian understory.	Low. No suitable habitat in BSA and nearest occurrence is approximately 40 miles southeast of the BSA (CDFW 2017).	No Effect
Mammals						
<i>Enhydra lutris nereis</i>	southern sea otter	FT	Found in nearshore marine environments	Associated with rocky substrates supporting kelp beds.	None. No habitat present in the BSA.	No Effect
<i>Corynorhinus townsendii</i>	Townsend's big-eared bat	CT/SSC	Most common in mesic sites. Forages in edge habitats along streams and in a variety of wooded habitats; will travel long distances while foraging.	Roosts in the open, hanging from walls and ceilings of caves, mines, buildings, tunnels, or other human-made structures, but may use hollow trees as roost sites. Roosting sites are limiting.	Low. Suitable roosting and foraging habitat not present in the Project footprint. Three occurrences are reported within 5 miles of the BSA (CDFW 2017).	-
<i>Neotoma fuscipes annectens</i>	San Francisco dusky-footed woodrat	SSC	Highly arboreal grasslands, scrub, and wooded areas of the San Francisco Bay area. Evergreen or live-oaks or other thick-leaved trees and shrubs are important habitat component.	Native to San Francisco and Santa Cruz Mountains and foothills.	Moderate. Suitable dense riparian habitat is present, but the BSA lacks the species' preferred evergreen and thick-leaved trees and shrubs in the understory. Nearest occurrence is approximately 10 miles south of the BSA (CDFW 2017).	-
<i>Taxidea taxus</i>	American badger	SSC	Most abundant in drier open stages of most shrub, forest, and herbaceous habitats, with friable soils.	Needs sufficient food, friable soils and open, uncultivated ground. Preys on burrowing rodents. Digs burrows.	Low. No habitat present in the BSA. Closest known CNDDB occurrence is approximately 13 miles south of the BSA.	-
Arthropods						
<i>Callophrys mossii bayensis</i>	San Bruno elfin butterfly	FE	Inhabits rocky outcrops and cliffs in coastal scrub.	On the San Francisco Peninsula, endemic to this habitat in California.	Low. No suitable habitat in BSA or in vicinity of the Project footprint. Nearest occurrence is approximately 30 miles north of the BSA (CDFW 2017).	No Effect
<i>Cicindela ohlone</i>	Ohlone tiger beetle	FE	Inhabits coastal prairie grasslands with poorly drained clay or sandy clay over Santa Cruz mudstone.	Endemic to Santa Cruz County.	Low. No suitable habitat in BSA. Nearest occurrence is approximately 13 miles south of the BSA (CDFW 2017).	No Effect

Table 3-2 Special-Status Animal Species with Potential to Occur in the Biological Study Area

Scientific Name	Common Name	USFWS ^a /CDFW ^b	General Habitat	Micro-Habitat	Potential to Occur	Potential Effects to Federally Listed Species
<i>Euphilotes enoptes smithi</i>	Smith's blue butterfly	FE	Found in coastal areas, dunes, and chaparral on cliffs.	One occurrence occurs in a dune-based maritime ponderosa pine forest.	Low. No suitable habitat in BSA. Nearest occurrence is approximately 13.5 miles south of the BSA (CDFW 2017).	No Effect
<i>Speyeria zereene myrtleae</i>	Myrtle's silverspot butterfly	FE	Restricted to areas immediately adjacent to the coast: dunes, scrub, and grasslands.	Is now only known from a few sites in northern Marin County. The eggs are laid only on species of <i>Viola</i> , possibly only <i>Viola adunca</i> .	Low. No suitable habitat in BSA; outside of species range. Nearest occurrence is approximately 11.5 miles north of the BSA (CDFW 2017).	No Effect
<i>Polyphylla barbata</i>	Mount Hermon June beetle	FE	Shallow pools away from main stream flows.	Winter: undercut banks with exposed roots; summer: leafy branches touching waters.	Low. No suitable habitat is present within the BSA. Nearest occurrence is approximately 12 miles east of the BSA near Scott's Valley (CDFW 2017).	No Effect

^a USFWS designations are as follows:

C = Candidate (candidate to become a listed species)

FE = Endangered (any species in danger of extinction throughout all or a significant portion of its range)

FT = Threatened (any species that is likely to become an endangered species within the foreseeable future throughout all or a significant portion of its range)

^b CDFW designations are as follows:

CT = Candidate Threatened

FP = Fully Protected

SE = Endangered (any species at risk of becoming extinct in all or a significant portion of its range)

ST = Threatened (any species that is likely to become an endangered species within the foreseeable future throughout all or a significant portion of its range)

SSC = Species of Special Concern

°C = degrees Celsius

AFS_T = American Fisheries Society Threatened

DPS = Distinct Population Segment

ESU = Evolutionarily Significant Unit

psu = Practical Salinity Unit

Sources: California Natural Diversity Database (CDFW 2017), National Marine Fisheries Service species list (NMFS 2017), Information for Planning and Conservation (USFWS 2017).

Chapter 4 Results: Biological Resources, Discussion of Impacts, and Mitigation

This chapter identifies Project-specific general avoidance and minimization measures (AMMs) and direct and indirect impacts to natural communities of special concern and special-status species that would be affected as a result of implementing the Project based on literature reviews and field evaluations. Direct impacts are Project impacts that are caused by or result from the proposed action and occur at the same time and place. Indirect impacts are Project impacts that are caused by or would result from the proposed action and that occur later in time or outside the Project limits but are still reasonably certain to occur. A description of the proposed general AMMs and a discussion of potential Project impacts and proposed mitigation follow.

4.1 General Avoidance and Minimization Measures

The general AMMs listed below will be incorporated into the proposed Project to reduce potential impacts to sensitive biological resources. Additional species-specific AMMs for CRLF, SFGS, and marbled murrelet are presented in Section 4.4.2.2. The measures will be communicated to the contractor using special provisions included in the contract bid solicitation package.

1. **Seasonal Avoidance.** To the extent practicable, construction will not occur during the wet season. Except for limited vegetation clearing (necessary to minimize impacts to nesting birds), work will be limited to the period from June 1 to October 31 to avoid the period when SFGS may be overwintering in uplands and CRLF are most active. Marbled murrelets are more active during this time but less likely to be affected by the proposed Project. Surveys for the marbled murrelet will be conducted in accordance with the MBTA and are discussed in Section 4.4.3.
2. **A USFWS-Approved Biological Monitor.** The names and qualifications of proposed biological monitor(s) will be submitted to the USFWS for approval prior to the start of construction. Through communication with the resident engineer, the USFWS-approved biological monitor will be onsite during all work that could reasonably result in take of CRLF, SFGS, or marbled murrelet. The

USFWS-approved biological monitor will have the authority to stop work that may result in the unauthorized take of special-status species.

3. **Worker Environmental Awareness Training.** Before beginning construction activities, a qualified biologist will conduct an education program for all Project construction personnel. At a minimum, the training will include a description of CRLF, SFGS, marbled murrelet, and migratory birds and their habitats; a discussion of the potential occurrence of these species within the Project footprint; an explanation of the status of these species and protection under FESA and CESA; the description of measures to be implemented to conserve listed species and their habitats as they relate to the work site; and the description of boundaries within which construction may occur. A fact sheet conveying this information will be prepared and distributed to the construction and Project personnel entering the Project footprint.
4. **Migratory Bird Treaty Act Protection.** To minimize and avoid take of migratory birds, their nests, and their young, Caltrans will conduct vegetation and tree trimming between September 30 and January 30 before Project construction. This work will be limited to vegetation and trees that are within the Project footprint. No grubbing or other ground-disturbing actions will occur during that period. Upon completion of vegetation and tree trimming, Caltrans will install stormwater and erosion control BMPs. A biological monitor with appropriate construction and species experience will conduct nest and bird surveys and other wildlife surveys before and during tree cutting. All work will be conducted under a Regional Water Board-approved Water Pollution Control Plan or Stormwater Pollution Prevention Plan (SWPPP). Vegetation will be cleared only where necessary and will be cut above soil level. This will allow plants that reproduce vegetatively to re-sprout after construction.

During the nesting season, pre-construction surveys for nesting birds, including the marbled murrelet, will be conducted by a qualified biologist no more than 72 hours prior to the start of construction activities. If work is to occur within 300 feet of active raptor nests or 50 feet of active passerine nests, a non-disturbance buffer will be established at a distance sufficient to minimize disturbance based on the nest location, topography, cover, the species' sensitivity to disturbance, and the intensity/type of potential disturbance. All clearing and grubbing of woody vegetation will be performed by hand or using light construction equipment, such as backhoes and excavators.

5. **Environmentally Sensitive Area Fencing.** Before starting construction, ESAs (defined as areas containing sensitive habitats adjacent to or within construction work areas for which physical disturbance is not allowed) will be clearly delineated using high-visibility orange fencing. The ESA fencing will remain in place throughout Project duration and will prevent construction equipment or personnel from entering sensitive habitat areas. The final Project plans will depict the locations where ESA fencing will be installed and how it will be assembled or constructed. The special provisions in the bid solicitation package will clearly describe acceptable fencing material and prohibited construction-related activities, vehicle operation, material and equipment storage, and other surface-disturbing activities within ESAs.

6. **Wildlife Exclusion Fencing.** Before starting construction, WEF will be installed along the Project footprint perimeter in the areas where wildlife could enter the Project site. Locations of the WEF will be determined in coordination with USFWS. The final Project plans will depict the locations where WEF fencing will be installed and how it will be assembled/constructed. The special provisions in the bid solicitation package will clearly describe acceptable WEF fencing material and proper WEF installation and maintenance. The WEF will remain in place throughout the Project duration, and will be regularly inspected for stranded animals and fully maintained.

7. **Implementation of Best Management Practices.** In accordance with North Coast Regional Water Quality Control Board requirements, a SWPPP will be developed and erosion control BMPs implemented to minimize wind- or water-related erosion. The Caltrans BMP Guidance Handbook provides guidance for the inclusion of provisions in all construction contracts to protect sensitive areas and prevent and minimize stormwater and non-stormwater discharges. At a minimum, protective measures will include:
 - a. Disallowing discharging of pollutants from vehicle and equipment cleaning into storm drains or watercourses.

 - b. Keeping vehicle and equipment fueling and maintenance operations at least 50 feet away from watercourses, except at established commercial gas stations or an established vehicle maintenance facility.

 - c. Collecting and disposing of concrete wastes and water from curing operations in appropriate washouts, located at least 50 feet from watercourses.

- d. Maintaining spill containment kits onsite at all times during construction operations and/or staging or fueling of equipment.
 - e. Using water trucks and dust palliatives to control dust in unvegetated areas and covering of temporary stockpiles when weather conditions require.
 - f. Installing coir rolls or straw wattles along or at the base of slopes during construction to capture sediment.
 - g. Protecting graded areas from erosion using a combination of silt fences, fiber rolls along toes of slopes or along edges of designated staging areas, and erosion control netting (jute or coir) as appropriate on sloped areas.
 - h. Establishing permanent erosion control measures such as bio-filtration strips and swales to receive stormwater discharges from the highway or other impervious surfaces to the maximum extent practicable.
8. **Construction Site Management Practices.** The following site restrictions will be implemented to avoid or minimize potential impacts on listed species and their habitats:
- a. Enforcing a speed limit of 15 miles per hour in the Project footprint in unpaved and paved areas to reduce dust and excessive soil disturbance.
 - b. Locating construction access, staging, storage, and parking areas within the Project right-of-way outside any designated ESA or outside the right-of-way in areas environmentally cleared and permitted by the contractor. The following areas will be limited to the minimum necessary to construct the proposed Project: access routes, staging and storage areas, and contractor parking. Routes and boundaries of roadwork will be clearly marked before initiating construction or grading.
 - c. Certifying, to the maximum extent practicable, borrow material is non-toxic and weed free.
 - d. Enclosing food and food-related trash items in sealed trash containers and removing them from the site at the end of each day.
 - e. Prohibiting pets from entering the Project footprint area during construction.

- f. Prohibiting firearms within the Project site, except for those carried by authorized security personnel or local, state, or federal law enforcement officials.
 - g. Maintaining equipment to prevent the leakage of vehicle fluids such as gasoline, oils, or solvents and developing a Spill Response Plan. Storing hazardous materials, such as fuels, oils, and solvents, in sealable containers in a designated location that is at least 50 feet from aquatic habitat.
 - h. Servicing vehicles and construction equipment, including fueling, cleaning, and maintenance, at least 50 feet from aquatic habitat unless separated by topographic or drainage barrier.
9. **Avoidance of Entrapment.** To prevent inadvertent entrapment of animals during construction, excavated, steep-walled holes or trenches more than 1 foot deep will be covered at the close of each working day using plywood or similar materials, or provided with one or more escape ramps constructed of earth fill or wooden planks. Before such holes or trenches are filled they must be thoroughly inspected for trapped animals. Replacement pipes, culverts, or similar structures stored in the Project area overnight will be inspected before they are subsequently moved, capped, and/or buried.
10. **Vegetation Removal.** Vegetation that is within the cut-and-fill line or growing in locations where permanent structures will be placed (e.g., RSP.) will be cleared. Vegetation will be cleared only where necessary and will be cut above soil level except in areas that will be excavated. This will allow plants that reproduce vegetatively to re-sprout after construction. Clearing and grubbing of woody vegetation will occur by hand or using construction equipment such as mowers, backhoes, and excavators. If clearing and grubbing occurs between February 1 and September 30, a qualified biologist will survey for nesting birds within the areas to be disturbed, including a perimeter buffer of 50 feet for passerines and 300 feet for raptors, before clearing activities begin.
11. **Replant, Reseed, and Restore Disturbed Areas.** Caltrans will restore temporarily disturbed areas to the maximum extent practicable. Exposed slopes and bare ground will be reseeded with native grasses and shrubs to stabilize and prevent erosion. Where disturbance includes the removal of trees and woody shrubs, native species will be replanted, based on the local species composition.

12. Reduce Spread of Invasive Species. To reduce the spread of invasive, non-native plant species and minimize the potential decrease of palatable vegetation for wildlife species, Caltrans will comply with Executive Order 13112. This order is provided to prevent the introduction of invasive species and provide for their control to minimize economic, ecological, and human-health impacts. In the event that noxious weeds are disturbed or removed during construction-related activities, the contractor will be required to contain the plant material associated with these noxious weeds and dispose of them in a manner that will not promote the spread of the species. The contractor will be responsible for obtaining all permits, licenses, and environmental clearances for properly disposing of materials. Areas subject to noxious weed removal or disturbance will be replanted with fast-growing native grasses or a native erosion-control seed mixture. Where seeding is not practical, the target areas within the Project footprint will be covered to the extent practicable with heavy black plastic solarization material until the end of the Project.

13. Inclement Weather Restriction. No work will occur during or within 24 hours following a rain event exceeding 0.2-inch as measured by the National Oceanic and Atmospheric Association National Weather Service for the Soquel, California, (SOQC1) base station, available at <http://www.wrh.noaa.gov/mtr/versprod.php?pil=RR5&sid=RSA>.

4.2 Natural Communities of Special Concern

The Project would temporarily impact 0.014 acre and permanently impact 0.038 acre of coastal bluff scrub habitat (Figure 3-1). Impacts to the habitat would result from vegetation removal and installation of the RSP. Affected areas will be revegetated after RSP is installed.

4.2.1 Wetlands and Other Waters of the United States

4.2.1.1 SURVEY RESULTS

No wetlands were found within Project footprint during surveys. One culverted water feature was identified in the Project footprint that is classified as waters of the United States: Elliot Creek (80 linear feet), which is a tributary to the Pacific Ocean (Figure 3-1 and Appendix D. This section of Elliot Creek is culverted and will be avoided; all work will be done above the banks of Elliot Creek.

4.2.1.2 AVOIDANCE AND MINIMIZATION MEASURES

No temporary or permanent impacts to wetlands are anticipated, as described in Section 4.2.1.1. The general construction AMMs described in Section 4.1 will be implemented to avoid and minimize potential impacts to waters of the United States. Some of these AMMs include construction work window, implementing dust control measures, and requiring dedicated fueling and refueling practices.

4.2.1.3 PROJECT IMPACTS

There are no expected permanent or temporary impacts to wetlands. Standard Caltrans erosion and siltation control BMPs will be placed prior to construction to protect Elliot Creek. The section of Elliot Creek within the Project footprint is culverted and will be avoided and all work would be done above the bank of Elliot Creek. Therefore, the Project would not have an impact on Elliot Creek.

4.2.1.4 COMPENSATORY MITIGATION

No compensatory mitigation is proposed because there would be no impact to wetlands or other waters.

4.2.2 Trees

On July 27, 2017, CH2M biologists Rachel Cotroneo and Caprice Lee mapped trees within the Project footprint. Elizabeth Leyvas (Caltrans) and Rachel Cotroneo (CH2M) worked with the Caltrans design team to minimize tree removal and determine which trees the Project would potentially impact.

4.2.2.1 SURVEY RESULTS

Trees potentially impacted (removed or trimmed) are shown in Figure 2-3. There are three Monterey pines located adjacent to the Project footprint (Figure 2-3) that are not anticipated to be impacted. These trees are within the native range for this species and therefore fall into the special status designation of 1B.1 (rare or endangered in California and elsewhere) (CDFW 2017, and Figure 2-1).

4.2.2.2 AVOIDANCE AND MINIMIZATION MEASURES

Attempts to minimize tree removal will include trimming wherever possible. Trees to be removed will be cut down to the stump and removed between September 30 and October 31, one year ahead of construction. No grubbing will occur during this time period.

For Monterey pine-specific AMMs, see Section 4.3.1.2.

4.2.2.3 PROJECT IMPACTS

Figure 2-3 shows trees that would be impacted by the proposed Project (see Section 4.2.2.1). One Monterey cypress (*Cupressus macrocarpa*) within the Project footprint would either be removed or trimmed to create a clear path for construction equipment. There are three Monterey pines located adjacent to the Project footprint. With implementation of the AMMs described in Section 4.3.1.2, Caltrans does not anticipate any permanent impacts to Monterey pine.

4.2.2.4 COMPENSATORY MITIGATION

Restoration for temporary impacts will be accomplished through revegetation onsite. No compensatory mitigation is proposed because there are no anticipated impacts to special-status species.

4.2.2.5 CUMULATIVE IMPACTS

With implementation of the AMMs described above, the Project would make no measurable contribution to cumulative impacts on trees.

4.3 Special-Status Plant Species

This section addresses the plant species that are documented or have the potential to occur in the BSA. A complete list of special-status species for the six-quadrangle region is provided in Appendix C. A plant was considered to have a special status if it meets at least one of the following criteria:

- Listed, proposed for listing, or a candidate for listing, as threatened or endangered under the FESA.
- Listed, or a candidate for listing, as rare, threatened, or endangered under the CESA.
- Listed in the Special Plants, Bryophytes, and Lichens List, as defined by the CNDDDB.
- Ranked by the CNPS as 1 or 2 in the current online version of its Inventory of Rare and Endangered Plants of California (CNPS 2017).

A species was determined to have the potential to occur in the BSA if it historically occurred within or adjacent to the BSA as documented in the CDFW Biogeographic Information and Observation System or CNDDDB (CDFW 2017), if its known or

expected geographic range was within the vicinity of the Project footprint, or if its known or expected habitat was present within or near the BSA.

Other than the species listed below, no other target special-status plants identified in Table 3-1, or any other special-status plant species, were observed within the BSA during the 2017 plant surveys. The complete results of the special-status plant survey is included in Appendix D.

4.3.1 Monterey Pine (*Pinus radiata*)

The CNPS considered the native Monterey pine to be Rare and Endangered (1B.1) in 1994 (CNPS 1995). The species is not listed as threatened or endangered under CESA or FESA.

Distribution

There are only three native stands of Monterey pine in California: in Ano Nuevo, Cambria, and the Monterey Peninsula (CNPS 2017). Only one-half of the species' historical extent remains undeveloped on the Monterey Peninsula, and forest destruction has been unevenly distributed over different geomorphic surfaces. Monterey pine has been introduced in many areas. This plant may become weedy or invasive in some regions or habitats and may displace desirable vegetation if not properly managed (NRCS 2003).

Description

Mature Monterey pines can reach 38 meters in height with trunks up to 2 meters in diameter. The young trees begin as compact pyramids but age into varied shapes. The adult canopy is usually rounded to flat-topped. The bark is red-brown to blackish brown and has deep furrows. The leaves are glossy, dark green needles, 6 to 15 centimeters long that grow in bundles of three. Needles on older trees are sometimes a bluish green. Flowers appear in late winter or early spring. The trees are monoecious, having both male and female flowers (USDA 2003). The species is one of the 18 California species of pines and cypresses that bear closed cones.

This species is the most widely cultivated pine in the world (USDA 2003). Monterey pines are also the most widely planted trees for choose-and-cut Christmas tree farms in California. They are excellent shade trees, act as effective wind and sound barriers, and have been used for erosion control.

Habitat Requirements

Monterey pines grow below 1,200 meters in closed cone pine forests and oak woodlands. Monterey pines are adapted to soils of medium to heavy texture. Monterey pines have serotinous cones that do not release seeds unless subjected to high temperatures. Superheating may occur on very hot days or during fire events. Because hot days do not often occur in the Central Coast region of California, replenishment of the seed bank is highly dependent on fire (Hillyard 1997).

Population Threats

The remaining stands of Monterey pine are threatened by numerous factors, including urbanization, genetic contamination, recreational development, fire suppression, pests, and diseases (USDA 2003 and CNPS 2017).

4.3.1.1 SURVEY RESULTS

On July 27, 2017, CH2M biologists Rachel Cotroneo and Caprice Lee mapped trees within the Project footprint. Three Monterey pines were identified adjacent to the Project footprint (Figure 2-3). The special-status designation of 1B.1 only applies to the natural native stands of Monterey pine. The Project falls within one of these designations, occurrence #5 (CDFW 2017 and Figure 2-1).

4.3.1.2 AVOIDANCE AND MINIMIZATION MEASURES

Elizabeth Leyvas (Caltrans) and Rachel Cotroneo (CH2M) worked with the Caltrans design team to minimize tree removal and determine which trees the Project would potentially impact. It was determined that the Monterey pine trees adjacent to the Project work area would be avoided.

In addition to this determination, the following AMMs are proposed:

- If practicable, avoid the tree and roots by placing an ESA fence around the outer limits of the canopy (the drip line) of all Monterey pines within or adjacent to the Project footprint.
- Avoid compacting the soil around the root zone by minimizing equipment being driven over the root zone.
- If equipment needs to be driven over the root zone, avoid compacting the soil by laying down several inches of mulch or mats before using of the equipment in these areas.

- If trimming needs to occur, a certified arborist needs to be onsite during any trimming.
- To maintain viability of the tree, no more than 20 percent of the canopy can be trimmed.

4.3.1.3 PROJECT IMPACTS

With implementation of the AMMs described above, Caltrans does not anticipate any permanent impacts to Monterey pine.

4.3.1.4 COMPENSATORY MITIGATION

There are no anticipated permanent impacts to Monterey Pine; therefore, no compensatory mitigation is proposed.

4.3.1.5 CUMULATIVE IMPACTS

With implementation of the AMMs described above, the Project would make no measurable contribution to cumulative impacts on Monterey Pine (*Pinus radiata*).

4.4 Special-Status Wildlife Species Occurrences

This section addresses the special-status wildlife species that have the potential or are known to occur in the BSA. A complete list of special-status species for the six-quadrangle region is provided in Appendix C.

4.4.1 California Red-legged Frog

The CRLF was federally listed as a threatened species under FESA on May 23, 1996 (61 *Federal Register* 25813).

CRLF Distribution

CRLF is distributed throughout 26 counties in California but is most abundant in the San Francisco Bay area. Populations have become isolated in the Sierra Nevada, northern Coast, and northern and southern Transverse and Peninsular ranges (Jennings and Hayes 1994; Stebbins 2003).

Habitat Requirements

CRLF predominantly inhabit permanent water sources such as streams, lakes, marshes, natural and manmade ponds, and ephemeral drainages in valley bottoms and foothills up to 4,900 feet in elevation (Jennings and Hayes 1994; Bulger et al. 2003; Stebbins 2003).

Breeding aquatic habitat consists of virtually all low-gradient freshwater (less than 7 parts per thousand salinity) bodies, including natural and manmade ponds; slow-moving streams and creeks; pools within streams; marshes; lagoons; and other ephemeral or permanent water bodies that typically become inundated during winter rains and hold water for a minimum of 20 weeks in all but the driest of years (USFWS 2008, 2010). Deep lacustrine water habitat (e.g., deep lakes and reservoirs 50 acres or larger in size) that are inhabited by predators, some non-native, do not provide habitat for CRLF (USFWS 2010). CRLF require a permanent water source to ensure that aquatic habitat is available year-round. Permanent water sources can include ponds, perennial creeks (or permanent plunge pools within intermittent creeks), seeps, and springs (USFWS 2010).

Aquatic breeding habitat must have a minimum water depth of 20 inches and must maintain water during the entire tadpole-rearing season identified as March through July (USFWS 2010). During periods of drought or less-than-average rainfall, these breeding sites may not hold water long enough for individuals to complete metamorphosis, but these sites would still be considered essential breeding habitat in wetter years (USFWS 2010).

While aquatic non-breeding habitat may not hold water long enough for CRLF to complete its aquatic lifecycle, it does provide for shelter, foraging, predator avoidance, and aquatic dispersal for juvenile and adult CRLF. Other wetland habitats that would meet these elements include plunge pools within intermittent creeks, seeps, quiet water refugia during high water flows, and springs of sufficient flow to withstand the summer dry period (USFWS 2008).

Essential upland habitat consists of all upland areas surrounding breeding and non-breeding habitat up to a distance of about 1 mile. This habitat comprises various plant communities including grasslands, woodlands, wetlands, and riparian habitat that provide shelter, forage, and predator avoidance. This upland habitat is required to maintain the hydrologic, geographic, topographic, ecological, and edaphic features supporting and surrounding the wetland or riparian habitat (USFWS 2008).

Essential dispersal habitat includes upland or riparian habitats that allows movement between subpopulations of CRLF (USFWS 2008). Dispersal habitat does not include barriers such as heavily traveled roads (i.e., average of 30 cars per hour from 10 p.m. to 4 a.m.) that lack bridges or culverts; moderate- to high-density urban or industrial developments; and large reservoirs over 50 acres in size (USFWS 2010). Agricultural

lands such as row crops, orchards, vineyards, and pastures do not constitute barriers to CRLF dispersal (USFWS 2008, 2010).

There are physical and biological features, known as primary constituent elements, required for the conservation of CRLF. These consist of two or more suitable breeding locations, a permanent water source, and associated uplands surrounding these water bodies up to 300 feet in from the water's edge—all within 1.25 miles of one another and connected by barrier-free dispersal habitat that is at least 300 feet wide (USFWS 2010).

Reproduction

CRLF breed between November and April in standing or slow-moving water at least 2.5 feet deep with emergent vegetation, such as cattails (*Typha* spp.), tules (*Scirpus* spp.), or overhanging willows (*Salix* spp. [Jennings and Hayes 1988]). Egg masses containing 2,000 to 5,000 eggs are attached to vegetation below the surface and hatch after 6 to 14 days (Storer 1925; Jennings and Hayes 1994). Larvae undergo metamorphoses 3.5 to 7 months after hatching and reach sexual maturity at 2 to 3 years of age (Jennings and Hayes 1994).

Movement

In a study of CRLF terrestrial activity in the Santa Cruz Mountains, Bulger et al. (2003) categorized terrestrial use as migratory and non-migratory. Non-migratory activity occurred over one to several days and was associated with precipitation events. Migratory movements were characterized as the movement between aquatic sites and were most often associated with breeding activities. Bulger et al. (2003) reported that non-migrating frogs typically stayed within 200 feet of aquatic habitat 90 percent of the time and were most often associated with dense vegetative cover (e.g., California blackberry, poison oak, and coyote brush). Migrating frogs were reported to have moved between sites that were separated by map distances 0.12 to 1.73 miles. The longest reported route traveled was 2.24 miles by an individual moving between two sites 1.73 miles apart.

Population Threats

Threats to the species include removal and alteration of habitat due to urbanization, fragmentation, overgrazing of aquatic and riparian habitats, erosion and siltation due to flooding, and predation by nonnative species.

4.4.1.1 SURVEY RESULTS

No protocol-level CRLF surveys were conducted as part of the background information collected for the Project. However, Caltrans relied on the best available scientific and commercial data, including a literature search and visual assessment, to evaluate the potential for this species to occur in the BSA and to infer presence.

A riparian corridor running perpendicular to SR 1 may provide upland habitat for CRLF, and it is within the central coast recovery unit for the species. Elliot Creek itself runs 20 feet underneath SR 1 in a culvert, making the associated riparian area atypical in vegetation makeup. The coastal scrub habitat within the Project footprint may provide upland dispersal habitat for CRLF. While small mammal burrows that may attract CRLF appear to be lacking within the coastal scrub, dense vegetation (including California blackberry and poison oak) provides refugia and potential opportunities for foraging.

The coastal scrub habitat within the Project footprint is primarily unvegetated and contains few features that would attract foraging or estivating CRLF. Any individuals in the Project footprint would likely be transient and/or dispersing and unlikely to use the Project footprint for any extended length of time. No CRLFs were observed onsite during reconnaissance site visits or focused botanical surveys.

A review of CNDDDB revealed four occurrences of CRLF within 2 miles of the Project footprint (Figure 2-2). The closest occurrence was in the year 2000 in the Año Nuevo State Reserve (occurrence #573, CDFW 2017). Habitat at this site consists of a freshwater pond with tules and willows, and surrounding uplands are coastal scrub. Adults were seen at this pond, and the CNDDDB-documented observations were during October. The Project footprint is within dispersal distance of this pond. The second closest occurrence was in 2001 and was located 1.3 miles south of the site in ephemeral and permanent ponds near the mouth of a lagoon at Waddell Creek (occurrence #471, CDFW 2017). The area is a coastal stream with marine influence and is surrounded by redwood forest. Vegetation in the pond consists of cattails and tules. The third closest occurrence (occurrence #313, CDFW 2017) was in July 1999, about 1.8 miles north of the site, and two adults were documented. The location was a large sag pond surrounded by bulrush and willow just east of SR 1. The farthest occurrence (occurrence #417, CDFW 2017) was found in 2000 in Green Oaks Creek about 0.5 mile east of SR 1. At least one CRLF was seen and others were heard in the ponds. The ponds were constructed in the 1970s and, in 2000, were found to be lined with sedges, oak, and redwoods.

In summary, appropriate upland dispersal habitat is present within the Project footprint and BSA for CRLF based on the presence of the primary constituent elements described and proximity to known occurrences. Therefore, CRLF may be present within the Project footprint during construction.

Standard avoidance and minimization measures will be incorporated into the Project to reduce the potential for adverse impacts to the species, as described in Section 4.4.1.2.

CRLF Critical Habitat

On March 17, 2010, USFWS issued the final designation of critical habitat for CRLF (75 *Federal Register* 12816–12959). The area that USFWS has designated as critical habitat for CRLF includes 1,681,938 acres in 27 California counties, in 48 units. The Project footprint overlaps with designated critical habitat for CRLF UNIT SNM-2 (Figure 4-2).

During field surveys, Caltrans biologists observed that the coastal scrub vegetation within the Project footprint contains the physical and biological factors of upland habitat for CRLF, including California blackberry, poison oak, grasses, and other upland species that may serve as foraging habitat or may provide shelter from predatory species (USFWS 2002). Proximity to riparian areas and ponds indicates that the coastal scrub habitat within the Project footprint may form part of a dispersal corridor for the species. SR 1 may act as an existing barrier to CRLF dispersal either directly through vehicular mortality or indirectly through population fragmentation or isolation. The ruderal and paved areas within the Project footprint do not contain the physical and biological factors of CRLF critical habitat and lack characteristics that would attract CRLF. If CRLFs occur in this area, they are likely transient.

Stressors to critical habitat as a result of the proposed action include the removal of soil, distribution of RSP, redistribution of soils, and altered contours. However, the impacted critical habitat area is already highly disturbed by erosional forces, is dominated by annual and low-growing vegetation, and provides access to more critical habitat with only marginal quality for CRLF. Following construction activities, the slope will be hydro-seeded with a native plant mix and will provide upland habitat for CRLF that is comparable to, if not higher than, the quality of the existing baseline. Due to these reasons, Caltrans has determined that the proposed impacts would not adversely modify critical habitat for the CRLF.

4.4.1.2 AVOIDANCE AND MINIMIZATION EFFORTS

As required under FESA, Caltrans will implement reasonable and prudent measures to minimize and avoid take of CRLF. Because suitable habitat is present and CRLF have been documented within 1.5 miles of the Project footprint, Caltrans will implement both the general AMMs in Section 1.4 and the following species-specific measures:

1. **Proper Use of Erosion Control Devices.** To prevent CRLF and SFGS from becoming entangled or trapped in erosion control materials, plastic monofilament netting (i.e., erosion control matting) or similar material will not be used within the Project footprint. Acceptable substitutes include coconut coir matting or tackifier hydro-seeding compounds.
2. **Pre-Construction Surveys.** Pre-construction surveys for CRLF, SFGS, and marbled murrelet will be conducted by the USFWS-approved biological monitor no more than 20 calendar days prior to any initial ground disturbance and immediately prior to ground-disturbing activities (including vegetation removal) within upland habitat identified for the CRLF in the August 2017 Biological Assessment (Caltrans 2017). These efforts will consist of walking surveys of the Project footprint and, if possible, accessible adjacent areas within at least 50 feet of the Project footprint. The biological monitor will investigate potential cover sites when it is feasible and safe to do so. This includes thorough investigation of mammal burrows, rocky outcrops, appropriately sized soil cracks, tree cavities, and debris. Native vertebrates found in the cover sites within the Project footprint will be documented and relocated to an adequate cover site in the vicinity.
3. **Biological Monitoring.** The USFWS-approved biological monitor will be present during construction activities where take of a listed species could occur. Through communication with the resident engineer or his/her designee, the USFWS-approved biological monitor may stop work if deemed necessary for any reason to protect listed species and will advise the resident engineer or designee on how to proceed.
4. **Protocol for Species Observation:** The USFWS-approved biological monitor(s) will have the authority to halt work through coordination with the resident engineer in the event that a listed species is observed in the Project footprint. The resident engineer will keep construction activities suspended in any construction area where the biologist has determined that a potential take of the species could occur. Work will resume after observed listed individuals leave the site



- LEGEND**
-  Project Footprint (0.53 acre)
 -  Potential California Red-legged Frog and San Francisco Garter Snake and San Francisco Dusky Footed Woodrat Dispersal Habitat
 -  Permanent Impacts to Habitat (0.038 acre)
 -  Temporary Impacts to Habitat (0.014 acre)

Service Layer Credits:
 Source: Esri, DigitalGlobe, GeoEye, Earthstar Geographics, CNES/Airbus DS, USDA, USGS, AeroGRID, IGN, and the GIS User Community
 Content may not reflect National Geographic's current map policy. Sources: National Geographic, Esri, DeLorme, HERE, UNEP-WCMC, USGS, NASA, ESA, METI, NRCAN, GEBCO, NOAA, increment P Corp.

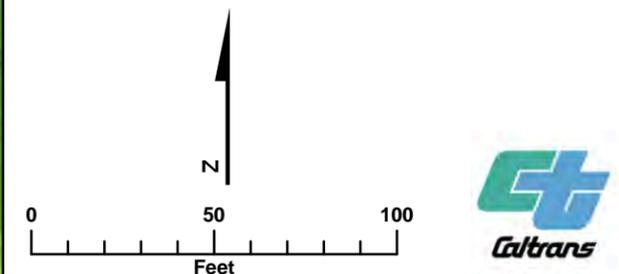
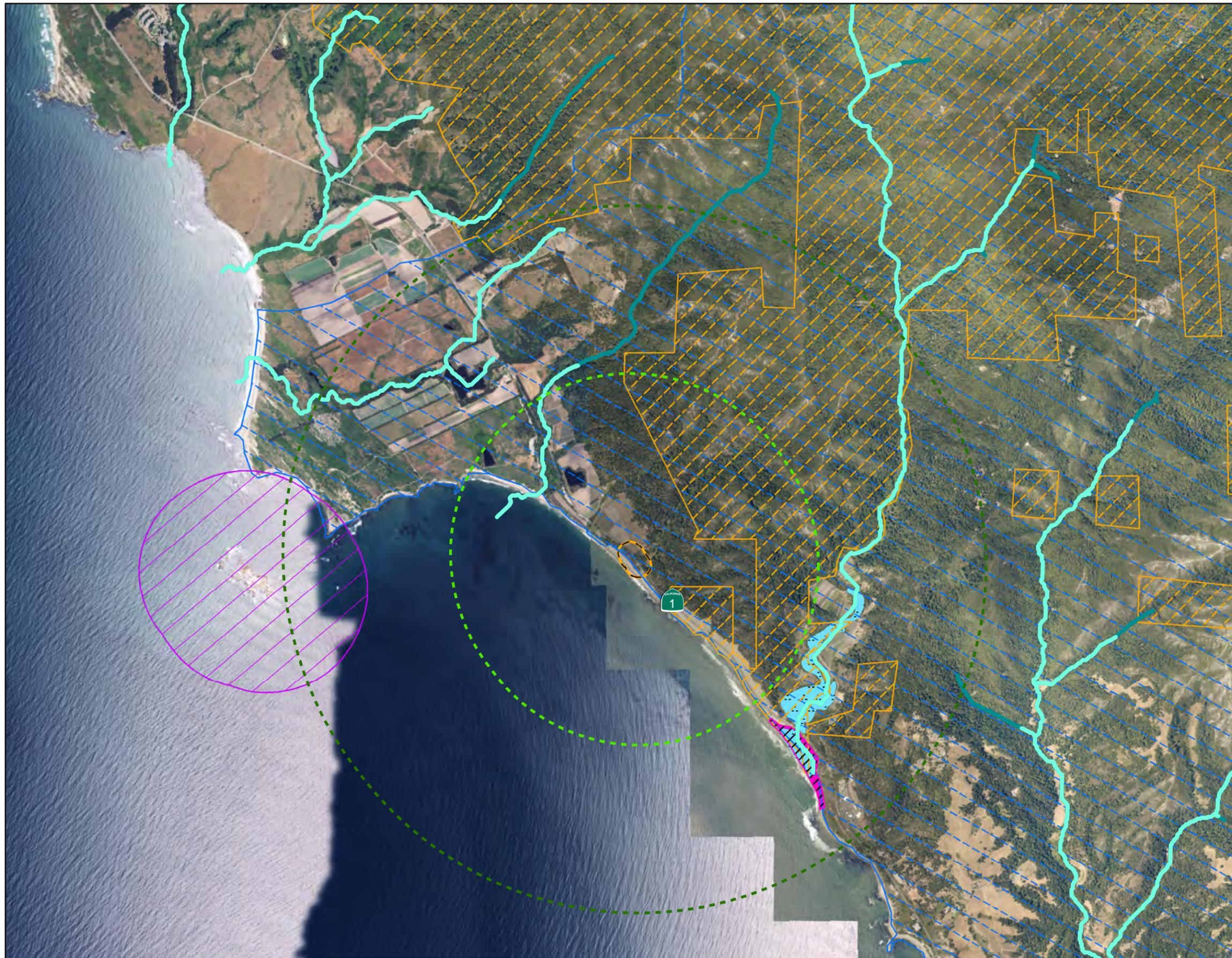

FIGURE 4-1
Potential Impacts to California Red-legged Frog and San Francisco Garter Snake and San Francisco Dusky Footed Woodrat Habitat
 Elliot Creek Storm Damage Project
 EA 0J201, SAN-1-Post Mile 0.01 - 0.3
 San Mateo County, California



- LEGEND**
- Biological Study Area (BSA)
 - 1 Mile from Biological Study Area
 - 2 Mile from Biological Study Area
 - Critical Habitat**
 - California red-legged frog (*Rana draytonii*)
 - Marbled murrelet (*Brachyramphus marmoratus*)
 - Steller sea lion (*Eumetopias jubatus*)
 - Tidewater goby (*Eucyclogobius newberryi*)
 - Western snowy plover (*Charadrius alexandrinus*)
 - Coho Salmon (*Oncorhynchus kisutch*) IP SWFSC
 - Steelhead (*Oncorhynchus mykiss*) IP SWFSC

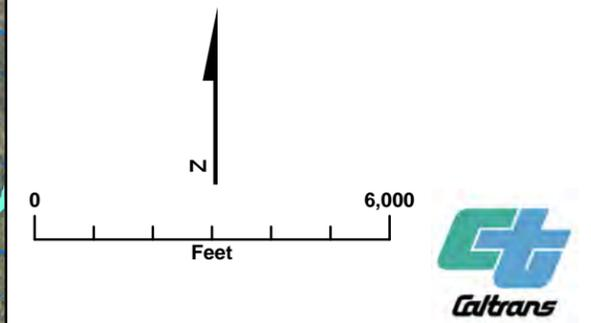

FIGURE 4-2
Elliot Creek Storm Damage Project
 EA 0J201, SAN-1-Post Mile 0.01 - 0.3
 San Mateo County, California

voluntarily, the biologist determines that no wildlife is being harassed or harmed by construction activities, or the wildlife is removed by the biologist to a release site using USFWS-approved handling techniques.

5. **Handling of Listed Species.** If a listed species is discovered, the resident engineer and USFWS-approved biological monitor will be immediately informed.
 - a. If a CRLF, SFGS, or marbled murrelet gains access to a construction zone, work will be halted immediately within 50 feet until the animal leaves the site or is captured and relocated by the USFWS-approved biological monitor.
 - b. The USFWS will be notified within one (1) working day if a CRLF, SFGS, or marbled murrelet is discovered within the construction site.
 - c. The captured CRLF, SFGS, or marbled murrelet will be released within appropriate habitat outside of the construction area but nearby the capture location. The release habitat will be determined by the USFWS-approved biological monitor.
 - d. The USFWS-approved biological monitor will take precautions to prevent introduction of amphibian diseases in accordance with the *Revised Guidance on Site Assessments and Field Surveys for the California Red-legged Frog* (USFWS 2005).

4.4.1.3 PROJECT IMPACTS

By implementing Caltrans general AMMs (see Section 4.1) and the CRLF-specific AMMs listed above, Caltrans anticipates adverse direct and indirect impacts to CRLF would be minimized. However, even with such measures, take of an individual CRLF may occur if the species is present during construction.

Direct Impacts

Adverse direct impacts to individual CRLF may result from the use of heavy equipment, night lighting, removal of vegetation, removal of soil, distribution of RSP, redistribution of soils, grading, dust, vibration and noise. These stressors are likely to affect juvenile or adult CRLF that are feeding, sheltering, or dispersing in uplands within the Project footprint.

The proposed action would result in 0.034 acre of permanent impacts and 0.018 acre of temporary impacts to upland dispersal/critical habitat for CRLF as a result of excavation and RSP placement (Figure 4-1). Stressors to critical habitat as a result of

the proposed action include the removal of soil, distribution of RSP, redistribution of soils, and altered contours. However, the critical habitat area where there would be Project impacts is already highly disturbed by erosional forces, is dominated by annual and low-growing vegetation, and provides access to more critical habitat with only marginal quality for CRLF. The quantity of habitat (0.034 acre) represents an insignificant impact when compared to the quantity of suitable upland and aquatic habitat in the areas surrounding the Project footprint.

Following construction activities, the slope will be hydro-seeded with a native plant mix, and any native large, woody, non-toxic plant material will be placed on top. This would provide upland habitat for CRLF that is similar, if not better than, the baseline.

The proposed action would create one new barrier to CRLF movement/dispersal in the form of a 60-foot-long asphalt concrete dike along the southbound direction of the highway. This is not expected to have major impacts to dispersal because the dike will be placed along an existing paved road.

Indirect Impacts

Project-related indirect impacts could include increased erosion, sedimentation, or changes in hydrology, any of which could occur either during construction or post-construction. The disturbance of upland areas and removal of vegetation could lead to an increased potential for erosion and sedimentation of soils, affecting CRLF habitats outside the Project footprint. For example, construction could result in indirect impacts to CRLF foraging habitat from increased sediment loads, turbidity, and siltation if soils enter the outfall of Elliot Creek.

In addition, construction activities could result in the introduction of chemical contaminants to a work site or staging area, such as oil or toxic chemicals leaking from construction equipment. Construction activities could also spread invasive species present in the BSA to other sites that support CRLF.

These indirect impacts will be avoided through implementation of the avoidance and minimization measures for protection of water quality, erosion control, and species-specific protection measures.

Table 4-1 Approximate Loss of CRLF Habitat Types

CRLF Habitat	Area (acres)
Upland Dispersal/Critical Habitat	
Permanent (will be restored after construction)	0.034
Temporary	0.018

In summary, the proposed Project would have short-term adverse impacts to CRLF dispersal/critical habitat and could result in loss of small numbers of CRLF, if they were to be present during construction. The Project would provide a permanent enhancement to CRLF habitat by revegetating the RSP area with native plants.

By implementing Caltrans general AMMs (see Section 4.1) and the CRLF-specific AMMs listed in Section 4.4.3.2, Caltrans anticipates direct or indirect impacts to CRLF to be minimized.

Following construction activities, the slope will be hydro-seeded with a native plant mix and will provide upland habitat for CRLF that is comparable to, if not higher than, the quality of the existing baseline. For these reasons, Caltrans has determined that the proposed impacts would not adversely modify CRLF critical habitat.

4.4.1.4 COMPENSATORY MITIGATION

Caltrans does not propose compensatory mitigation for CRLF for the following reasons:

- As required under FESA, Caltrans will implement measures to avoid and minimize take (Sections 4.1, 4.4.2.2, and 4.4.3.2). By implementing these measures, impacts to and potential take of CRLF habitat and individuals would be minimized.
- Several design alternatives were analyzed for this Project. Caltrans biologists worked closely with project engineers to limit the size and scope of the Project.
- Permanent impacts to CRLF dispersal/critical habitat are considered low. All impacted areas will be revegetated after construction with native vegetation.

4.4.1.5 CUMULATIVE IMPACTS

Cumulative impacts on CRLF result from past, current, and reasonably foreseeable future projects in the region, including periodic maintenance and replacement of

bridges and culverts throughout San Mateo County and storm damage projects throughout the region. These projects will all undergo (or have undergone) separate environmental review and will require separate environmental permitting from regulatory agencies. Although these and similar projects could result in impacts on CRLF, most current and future projects that impact this species and its habitats are expected to be required to mitigate these impacts through the CEQA, Section 1600 of the F.G.C., or Sections 401/404 Clean Water Act permitting processes. As a result, most projects in the region will mitigate their impacts to CRLF, minimizing cumulative impacts to this species. With implementation of AMMs, this Project would not make a considerable contribution to cumulative impacts on the CRLF.

4.4.2 San Francisco Garter Snake

The SFGS was federally listed as endangered on March 11, 1967 (32 *Federal Register* 4001). The species is also state listed as endangered and is a California fully protected species. The SFGS is limited in distribution to portions of San Mateo and Santa Cruz counties. Remnant populations have been identified throughout the species' historic range. These include the West of Bayshore population (near San Francisco Airport), the Laguna Salada population (near Mori Point), the San Francisco State Fish and Game Refuge population (near Crystal Springs and San Andreas reservoirs), the Pescadero Marsh population, the Año Nuevo State Reserve population, and the Cascade Ranch population (USFWS 2006).

In a 5-year review of the status of the SFGS, the USFWS identified several primary habitat elements essential to support SFGS breeding (USFWS 2006). These elements include open grassy uplands with a flora composition consisting of such species as coyote bush, wild oat, wild barley (*Hordeum* spp.), and various brome species (*Bromus* spp.); a grassland/shrub matrix within these uplands with brush densities ranging from one average plant per 98 square feet (ft²) to one large plant per 66 ft² to allow sufficient cover from predators; upland estivation habitat in the way of small mammal burrows; freshwater habitat containing emergent vegetation such as cattails (*Typha* spp.), spike rush (*Eleocharis* spp.), water plantain (*Alisma* spp.), willow (*Salix* spp.), and *Rubus* species; open water and shallow water components to the wetlands; a breeding prey base of CRLF and Pacific tree frogs (*Hyla regilla*); and a potential preference toward slopes with southern or western facing exposures. According to USFWS's review of dispersal data, SFGS have been known to move on average between 328 feet and 656 feet from pond foraging habitat to upland wintering sites, and some individuals have been observed to move more than 2,200 feet (USFWS 2006). Typically, SFGS do not appear to move distances of more than 0.60 mile,

although longer SFGS movements may occur in pursuit of prey (USFWS 2006). SFGS are not known to exhibit the wide-ranging movements associated with CRLF (McGinnis et al. 1987).

Unlike other garter snakes in the San Francisco Bay area, the SFGS does not appear to undergo true hibernation during the winter months and instead emerges periodically from hibernacula during the winter to bask. SFGS are most active between the spring and fall. Peak activity is observed between March and July, when adults emerge from hibernacula and concentrate around aquatic habitats to mate and forage for food (USFWS 2006).

The presence of habitat conditions that encourage viable breeding populations of Pacific tree frogs and CRLF is crucial to the survival of SFGS. Breeding populations of SFGS are unknown in locations where amphibian prey is absent (USFWS 2006). SFGS avoid brackish marsh areas because their preferred prey base (Pacific tree frogs and CRLF) cannot survive in saline water. Therefore, increased levels of salinity in freshwater corridors are also a threat to SFGS (USFWS 2006). Roads and highways affect the dispersal and movement of SFGS. In addition to direct mortality of the SFGS, highways affect dispersal and movement of the species' amphibian prey. Roads with a vehicle frequency above 30 cars per hour between 10 p.m. and 4 a.m. may serve as effective barriers to SFGS dispersal because of the nocturnal habits of many amphibians and the associated fatalities from vehicular strikes (USFWS 2006).

4.4.2.1 SURVEY RESULTS

No protocol-level SFGS surveys were conducted as part of the background information collected for the Project. However, Caltrans relied on the best available scientific and commercial data, including a literature search and a visual assessment, to evaluate the potential for the occurrence of this species in the BSA and to infer presence.

A review of CNDDDB reveals six SFGS occurrences within 2 miles of the Project footprint (Figure 2-2). The occurrence nearest the Project footprint (occurrence #73) is 0.49 mile north on the property owned by Coastways Ranch, Inc. The CNDDDB record was first observed in 1988 and notes that aerials taken from 2005 to 2014 show a pond with conditions favorable to SFGS, however, the pond is surrounded by agriculture to the north, south, and east, and it borders SR 1 about 330 feet to the west.

The next nearest occurrence (occurrence #72) is 0.91 mile north of the Project footprint (CDFW 2017). An individual SFGS was found and collected at the entrance to Año Nuevo State Reserve just west of SR 1. Two individuals were collected in different years and listed as the same occurrence. The first was collected on April 4, 1993, and another was collected on July 3, 1995. The California Academy of Science collected the specimens and stated that they were most likely heading east toward Año Nuevo Creek when they were struck by vehicles on SR 1.

The next nearest occurrence (occurrence #14) is 0.96 mile north of the Project footprint, west of SR 1, and near the coast (CDFW 2017). Occurrence #14 was found in the main pond, or “headquarters pond,” of Año Nuevo State Reserve on multiple dates as far back as 1971 and as recent as October 16, 2015, with a steady decrease in numbers of individuals (i.e., 34 adults and 19 juveniles were seen in 1971 and only adults were seen in 2015). Bullfrog (*Rana catesbiana*), Pacific tree frog, and CRLF are all found within this pond.

The next nearest occurrence (occurrence #30) is 1.24 miles south in several ponds about 0.3 miles northeast the mouth of Waddell Creek at Rancho del Oso State Park and east of SR 1 (CDFW 2017). Surrounding vegetation at the time (1987-2004) was thick blackberry, salix, equisetum, juncus, and other wetland/marsh vegetation, as well as riparian and woodland habitat. Sixteen adults and three juveniles were seen as recently as May 2004. One was seen dead on the road in 1987.

The next nearest occurrence (occurrence #71) is 1.84 miles northwest of the Project footprint (CDFW 2017). The first occurrence at this site was in 1971 and was found in a pond in the sand dunes at Año Nuevo State Reserve. One specimen was collected on July 30, 1992.

The next nearest occurrence (occurrence #15) is 1.87 miles northwest of the Project footprint (CDFW 2017). Individuals were seen in a pond at the north end of Año Nuevo beach area along Green Oaks Creek (just north of Año Nuevo Creek and east of SR 1).

Strips of vegetation to the west of SR 1 may act as corridors for SFGS from breeding populations and ponds north of the Project footprint to uplands within the footprint. The majority of land use to the north of the site and east of SR 1 is agricultural fields with some ruderal vegetation and Monterey pine lining the highway. Immediately south and west of the site vegetation consists of coastal bluff scrub and ruderal plants. Farther south and west is sand and compacted soil, and at the Santa Cruz County line,

the land immediately surrounding SR 1 to the east and west is barren, compacted soil all the way to Waddell Creek Rancho del Oso State park, where occurrence #30 was observed.

Coastal scrub habitat within the Project footprint provides suitable upland dispersal/overwintering habitat for SFGS because of the proximity to the drainage corridor (Elliot Creek); however, it lacks the open grassy characteristics and small mammal burrows which SFGS may prefer. Elliot Creek itself is not suitable habitat for SFGS breeding because of its fast pace, lack of ponds, and lack of prey items. Because SR 1 has been known to be dangerous to SFGS, proper WEF fencing will be put into place (see Section 4.4.1.2) to keep SFGS out of the work area.

4.4.2.2 AVOIDANCE AND MINIMIZATION MEASURES

As required under FESA, Caltrans will implement reasonable and prudent measures to minimize and avoid take of SFGS. Because suitable habitat is present and SFGS have been documented within 1.0 mile of the Project footprint, Caltrans will implement both the general AMMs in Section 1.4 and the species-specific measures identified in Section 4.4.1.2.

4.2.2.2 CRITICAL HABITAT

No critical habitat has been federally designated for this species.

4.4.2.3 PROJECT IMPACTS

By implementing the conservation measures presented in Section 1.4 and 4.4.1.2, no take, as defined in Section 86 of the F.G.C., is anticipated. However, not all adverse impacts (harm, harassment) can be eliminated because the disturbance of potentially suitable upland habitat is essential for the implementation of the Project.

Direct Impacts

The proposed Project will create stressors to individual SFGS, including the use of heavy equipment, use of night lighting, removal of vegetation, removal of soil, distribution of RSP, redistribution of soils, grading, dust, and noise. These stressors are likely to affect adult or juvenile SFGS that are feeding or overwintering in upland dispersal habitat. If present during construction, SFGS could be displaced temporarily from the Project footprint as a result of construction noise or vibrations. Due to the short construction duration (approximately 40 days) and the abundant and more suitable upland habitat that is available outside the Project footprint, this impact is unlikely to disrupt essential SFGS life history functions. Construction activities

would take place between July 2018 and October 31, 2018, when SFGS is unlikely to be overwintering in uplands.

SFGS could use portions of the Project footprint on or adjacent to the roadway for basking and could be inadvertently crushed by construction equipment; however, SFGS would likely be highly conspicuous under such circumstances and will be avoided with the use of biological monitors as described in the avoidance and minimization measures for this species in Section 4.4.1.2.

The proposed Project would also result in 0.034 acre of permanent impacts to SFGS upland habitat as a result of excavation and RSP placement (Figure 4-1 and Table 4-3). The impacted area is already highly disturbed by erosional forces, is currently unvegetated, and only provides marginal habitat. Following construction activities, the slope will be hydro-seeded with a native plant mix and would provide upland habitat for SFGS that improves upon the baseline.

Indirect Impact

Project-related indirect impacts could include an increased potential for erosion and sedimentation of soils within SFGS habitat in the Project footprint. Construction could result in indirect impacts on SFGS aquatic habitat from increased sediment loads, turbidity, and siltation if soils entered nearby water features, adversely affecting SFGS and potential prey for SFGS. In addition, construction activities could result in the introduction of chemical contaminants to a work site or staging area, such as oil or toxic chemicals leaking from construction equipment. Construction activities could also spread invasive species present in the Project footprint to other sites that support SFGS. Indirect impacts would be avoided through implementation of avoidance and minimization measures for protection of water quality, erosion control, and species-specific protection measures.

The project would not create any new barriers to dispersal. SR 92 may act as a pre-existing barrier to species movement, but amphibians are likely to traverse up the existing drainage corridor as opposed to across the proposed Project footprint.

Table 4-3 Potential Impacts to SFGS Habitat

Resource	Temporary Impacts (acres)	Permanent Impacts (acres)
SFGS Upland Dispersal Habitat	0.018	0.034

In summary, the proposed Project would have short-term adverse impacts to SFGS upland dispersal habitat and could result in loss of small numbers of SFGS, if they were to be present during construction. The Project would provide a permanent enhancement to SFGS habitat by revegetating the RSP area with native plants.

By implementing Caltrans general AMMs (see Section 4.1) and the CRLF/SFGS-specific AMMs listed above in Section 4.4.1.2, Caltrans anticipates direct or indirect impacts to SFGS would be minimized.

4.4.2.4 COMPENSATORY MITIGATION

Caltrans does not propose compensatory mitigation for SFGS for the following reasons:

- As required under FESA, Caltrans will implement measures to avoid and minimize take (Sections 4.1, 4.4.2.2, and 4.4.3.2). By implementing these measures, impacts and potential take of SFGS habitat and individuals would be minimized.
- Several design alternatives were analyzed for this Project. Caltrans biologists worked closely with project engineers to limit the size and scope of the Project.
- Permanent impacts to SFGS dispersal are considered low. All impacted areas will be revegetated after construction with native vegetation.

4.4.2.5 CUMULATIVE IMPACTS

Cumulative impacts on SFGS result from past, current, and reasonably foreseeable future projects in the region, including periodic maintenance and replacement of bridges and culverts throughout San Mateo County and storm damage projects throughout the region. These projects will all undergo (or have undergone) separate environmental review and will require separate environmental permitting from regulatory agencies. Although these and similar projects could result in impacts on SFGS, most current and future projects that would have impacts to this species and its

habitats are expected to be required to mitigate these impacts through the CEQA, Section 1600 of the F.G.C., or Sections 401/404 Clean Water Act permitting processes. As a result, most projects in the region will mitigate their impacts to SFGS, minimizing cumulative impacts to this species. With implementation of AMMs, this Project would not make a considerable contribution to cumulative impacts on the SFGS.

4.4.3 Marbled Murrelet

The marbled murrelet was federally listed as a threatened species on September 28, 1992 (USFWS 1992). A recovery plan was published for this species on September 24, 1997 (USFWS 1997). Critical habitat was designated (final rule) on May 24, 1996 (USFWS 1996), and a final revision was published on October 4, 2011 (USFWS 2011). There is no critical habitat for marbled murrelet within the Project footprint; the closest critical habitat unit for this species is 0.25 mile south of the Project footprint and 0.4 mile east of the footprint just within the Santa Cruz County line. Critical habitat unit CA-14-b encompasses approximately 20,482 acres (less than 0.1 percent) (USFWS 1996) near the southernmost extent of the total 3,698,100 acres of critical habitat that has been designated for this species. A total of 597,713 acres of critical habitat for marbled murrelet is located in California (USFWS 2011).

The marbled murrelet is a relatively small, stout seabird. The breeding range for this species occurs in six geographic zones along the Pacific Coast from Alaska south coastally through British Columbia, Washington, Oregon, to the northern Monterey Bay in central California (USFWS 1997). These geographic zones of occurrence are generally associated with large tracts of old growth forest in proximity to the coast, three of which are located in California (Siskiyou Coast Range, Mendocino, and Santa Cruz Mountains). Birds winter throughout the breeding range and also in small numbers off the southern California coast (USFWS 1997). The southernmost Santa Cruz Mountains breeding population, located nearest the Project footprint, is separated by nearly 300 miles from the neighboring population to the north (USFWS 1997). Population estimates from the late 1990s suggests several thousand up to 6,000 individuals may occur in California, compared to estimates of 60,000 that may have occurred historically (USFWS 1997).

The marbled murrelet has a unique life history compared to most seabirds; they forage in nearshore marine waters but fly inland (up to 50 miles) to nest on large limbs of mature conifers (USFWS 1997). Individuals have been detected at inland sites during all times of year; however, detections at inland sites are more frequent

during the breeding season (late March through late September). During the nesting season, adults take turns incubating nests and feeding young between foraging bouts to the ocean that can occur up to eight times a day; flights between foraging and nesting sites occur at all times during the day but most often occur at dawn and dusk (USFWS 1997).

Marbled murrelets use forest stands with old-growth characteristics generally within 50 miles of the coast (USFWS 1997). For nesting, they require old-growth or mature trees (more than 30-inch diameter at breast height) with large branches or deformities for nest platforms, or platforms created by mistletoe infestations (USFWS 1997). Nests in California have been located in stands containing old-growth redwood and Douglas fir (USFWS 1997).

Primary threats to this species include loss of nesting habitat, poor reproductive success and predation, marine pollution, and possibly changes in prey abundance and distribution (USFWS 1997)

4.4.3.1 SURVEY RESULTS

No protocol-level surveys for marbled murrelet have been conducted in the Project footprint. The species is generally difficult to observe, even during focused surveys, and negative results may not preclude the need for consultation. Reconnaissance surveys were conducted on December 29, 2016, April 27, 2017, and July 27, 2017, to determine whether the habitat for this species is present in the Project footprint. No marbled murrelets were observed during these site reconnaissance visits. While foraging, roosting, and nesting habitats are not present in the Project footprint, the footprint intersects a riparian corridor between suitable marine and inland habitats for this species. According to the CNDDDB, the nearest recorded occurrence of marbled murrelet is approximately 1.8 miles from the Project footprint. Therefore, marbled murrelet could occur in or near the Project footprint during flights to and from marine and inland habitats.

The CNDDDB record of marbled murrelet consists of several sightings in Lair Gulch (northeast of the mouth of Waddell Creek) from 1997 to 2001 (CDFW 2017). During that timeframe a failed nest and three individual birds were documented (occurrence #4).

There are three other occurrences ranging from 2.3 to 2.6 miles north and east of the Project footprint. The two nearest occurrences (occurrences #28 and #29) were that of several adult birds displaying “occupied habitat” behavior, recorded in 1988 to 1993.

The farthest occurrence (occurrence #6) documented 11 adults displaying occupied habitat, and one dead nestling that was presumed to be killed by predation. Each of these occurrences were in streams larger than Elliot Creek.

4.4.3.2 AVOIDANCE AND MINIMIZATION EFFORTS

Caltrans will implement standard construction BMPs during Project construction, including pre-construction surveys for nesting birds, as described in Section 4.1, to minimize the potential for disturbance to sensitive species and habitats. The marbled murrelet has the potential to use the Project footprint for foraging; therefore, most of the conservation measures specified in Section 4.1 apply to this species, and no extra species-specific measures will be necessary to avoid take of this species.

4.2.2.3 CRITICAL HABITAT

The Project footprint is not within federally designated critical habitat for marbled murrelet (USFWS 2011). The closest critical habitat unit is approximately 0.25 mile south of the Project footprint and 0.4 mile east of the footprint just within the Santa Cruz County line (Unit CA-14-b) (Figure 4-2).

4.4.3.3 PROJECT IMPACTS

By implementing the conservation measures presented in Section 4.1, no take, as defined in Section 86 of the F.G.C., is anticipated, and no adverse impacts (harm, harassment) are expected. However, some other impacts may occur.

Direct Impacts

No suitable foraging, nesting, or roosting habitat is present in the BSA. Individuals may occur above the BSA during flights between marine and inland habitats in the region and could therefore be subject to noise and visual disturbances from construction of the proposed Project; however, inland flights primarily occur at dawn and dusk when construction activities would be just beginning or ending. The potential for exposure of marbled murrelet to construction disturbance would be low and duration brief because individuals would only be present near the BSA for very short periods when flying over the Project. Furthermore, construction disturbance would occur over a relatively short period (2-month construction period relative to the 6-month breeding season) and over a minimal area relative to the distance they are accustomed to traveling between marine and inland sites. The Project would also occur in the context of existing roadway disturbance along SR 1. Therefore, potential impacts of the proposed Project on marbled murrelets are considered insignificant and discountable, and they are unlikely to rise to the level of take.

Indirect impacts

No indirect impacts to marbled murrelets are anticipated.

4.4.3.4 COMPENSATORY MITIGATION

Caltrans does not anticipate any impacts to marbled murrelet and therefore does not propose compensatory mitigation.

4.4.3.5 CUMULATIVE IMPACTS

Cumulative impacts on the marbled murrelet result from past, current, and reasonably foreseeable future projects in the region, including periodic maintenance and replacement of bridges and culverts throughout San Mateo County and storm damage projects throughout the region. These projects will all undergo (or have undergone) separate environmental review and will require separate environmental permitting from regulatory agencies. Although these and similar projects could result in impacts on marbled murrelets, most current and future projects that would impact this species and its habitats are expected to be required to mitigate these impacts through the CEQA, Section 1600 of the F.G.C., or Sections 401/404 Clean Water Act permitting processes. As a result, most projects in the region will mitigate their impacts to marbled murrelets, minimizing cumulative impacts to this species. With implementation of AMMs, this Project would not make a considerable contribution to cumulative impacts on the marbled murrelet.

4.4.4 San Francisco Dusky-Footed Woodrat

The San Francisco dusky-footed woodrat is listed as a California species of special concern. This species is found throughout the San Francisco Bay area and south to Monterey (Hall 1981, as cited in California State University, Stanislaus 2014; Carraway and Verts 1991), generally in forested habitats with moderate canopy, year-round greenery, a brushy understory, and a sufficient supply of suitable nest building materials (see below) (California Department of Fish and Game [CDFG] 2008). Evergreen or live oaks or other thick-leaved trees and shrubs are important habitat elements for this species (Kelly 1990 and Williams et al. 1992; as cited in California State University, Stanislaus 2014).

The San Francisco dusky-footed woodrat is highly arboreal (Kelly 1990). The species is a generalist herbivore, and individuals forage on the ground and in bushes and trees, primarily on woody plants such as live oak, maple, alder, coffeeberry, and elderberry; they also consume fungi, flowers, grasses, and acorns (CDFG 2008). Dusky-footed woodrat is nocturnal and active all year long. The breeding season spans from December to September, with a peak in mid-spring (CDFG 2008).

San Francisco dusky-footed woodrat builds mounded stick nests that can measure 3 to 8 feet across and as much as 6 feet tall (Santa Cruz Mountains Bioregional Council 2004). Nests typically are placed on the ground in areas of dense brush, against or straddling a log or roots of an adjacent tree. They may also be constructed in crotches or cavities of trees or logs, or occasionally higher up in trees, primarily evergreen oaks (California State University, Stanislaus 2014). A well-developed understory at the base of a single evergreen may be suitable for a single individual (CDFG 2008).

4.4.4.1 SURVEY RESULTS

No San Francisco dusky-footed woodrat or dens have been documented in the BSA; however, no focused surveys for this species have been conducted for the Project. No CNDDDB records for this species occur within 5 miles of the BSA (CDFW 2017). Monterey pine riparian forest along the Elliot Creek corridor in the BSA may provide suitable habitat for this species. Dense understory forest habitat is present within the Project footprint. In addition, potential habitat in the BSA occurs adjacent to a heavily traveled roadway (SR 1) with persistent noise disturbance. Therefore, San Francisco dusky-footed woodrat could occur in the BSA, albeit habitat suitability is poor.

4.4.4.2 AVOIDANCE AND MINIMIZATION EFFORTS

Caltrans will implement standard construction BMPs during Project construction, including pre-construction surveys, as described in Section 4.1, to minimize the potential for disturbance to sensitive species and habitats. The following additional species-specific measures will be implemented to minimize potential adverse impacts on the San Francisco dusky-footed woodrat:

1. **Pre-construction Surveys for San Francisco Dusky-Footed Woodrat.** Before the start of construction, a qualified biologist will conduct a survey of the Project footprint and a 30-foot buffer beyond the Project footprint boundaries to determine the location of active and inactive woodrat dens. Any dens detected during the surveys will be recorded and mapped in relation to the construction disturbance footprint. In addition, the biologist will evaluate any signs of current woodrat activity, including the presence of fresh scat, freshly chewed vegetation, and the presence of cobwebs covering nest entrances. A 30-foot equipment exclusion buffer will be established around active and inactive dens that can be avoided; within such buffers, all vegetation will be retained and nests will remain undisturbed.
2. **Potential Trapping and Relocation.** If the Project cannot avoid impacts on an active den(s), then a trapping and relocation effort will be implemented.

Relocation of trapped woodrats will occur as close as possible to the original den site. If suitable habitat is not available for relocation of woodrats in the Project vicinity, offsite locations will be identified. Trapping of woodrats will be conducted by a qualified biologist who has a current CDFW collection permit to trap and relocate the species. Such trapping will occur outside the breeding season, between September and December. Specific methods for trapping woodrats and relocation of individuals and their nest sites, including identification of suitable sites for relocation, will be developed in collaboration with CDFW, but likely will be similar to methods employed for other projects in the region, such as those used for the SR 152 Hecker Pass Safety Improvements Project (CDFW 2013) or State Route 9 Storm Damage Project.

4.4.4.3 PROJECT IMPACTS

The removal of the vegetation within approximately 0.034 acre of coastal bluff scrub for the RSP would constitute a minor loss of potential habitat for San Francisco dusky-footed woodrat (Figure 4-1 and Table 4-4). Because understory vegetation removal would occur along or adjacent to a steep roadway embankment that is subject to regular disturbance from a highly traveled roadway (SR 1), the loss of this potential habitat is not likely to adversely affect the local population.

Ground-disturbing activities could destroy woodrat dens or injure or kill woodrats inhabiting dens, if they occur within the Project footprint. Woodrats are nocturnal and might reside within dens during daytime construction activities. The Project also could disturb or displace woodrats from nearby dens if they occur in proximity to construction activities.

Table 4-4 Potential Impacts to SF DFWR Habitat

Resource	Temporary Impacts (acres)	Permanent Impacts (acres)
San Francisco dusky-footed woodrat Habitat	0.018	0.034

4.4.4.4 COMPENSATORY MITIGATION

Caltrans will not implement compensatory mitigation for impacts on San Francisco dusky-footed woodrat because only a relatively small area (0.034 acre) of habitat for this species along an existing roadway would be affected by the Project. In addition, AMMs will be implemented to avoid and minimize adverse impacts on this species.

For these reasons, no compensatory mitigation is proposed for the anticipated minor project impacts on San Francisco dusky-footed woodrat.

4.4.4.5 CUMULATIVE IMPACTS

Cumulative impacts on San Francisco dusky-footed woodrat result from past, current, and reasonably foreseeable future projects in the region, including periodic maintenance and replacement of bridges and culverts throughout San Mateo County and storm damage projects throughout the region. These projects will all undergo (or have undergone) separate environmental review and will require separate environmental permitting from regulatory agencies. Although these and similar projects could result in impacts on San Francisco dusky-footed woodrat, most current and future projects that would impact this species and its habitats are expected to be required to mitigate these impacts through the CEQA, Section 1600 of the F.G.C., permitting processes. As a result, most projects in the region will mitigate their impacts to San Francisco dusky-footed woodrat, minimizing cumulative impacts to this species. With implementation of AMMs, this Project would not make a considerable contribution to cumulative impacts on the San Francisco dusky-footed woodrat.

Chapter 5 Permits, Laws, Regulations, and Conclusions

5.1 Regulatory Requirements

Caltrans would obtain the following permits to complete construction of this Project:

- Section 7 Biological Opinion from USFWS (Section 7(a)(2) of FESA), received September 20, 2017
- Coastal Development Permit from California Coastal Commission

5.2 Federal Endangered Species Act Consultation Summary

- On August 17, 2017, Caltrans sent the USFWS a letter and a Biological Assessment for CRLF, SFGS, and marbled murrelet, requesting concurrence with the following determinations: The Project may affect and is likely to adversely affect CRLF and SFGS, and it is not likely to adversely affect marbled murrelet.
- On August 21, 2017, Caltrans received an email from John Cleckler of USFWS requesting additional information about the Project. Mr. Cleckler mentioned that the email was equivalent to a 30-day letter.
- On September 20, 2017, Caltrans received the Biological Opinion for the Elliot Creek Storm Damage Project, Caltrans ES 0J210, from USFWS.

Based on the analysis presented in the Biological Assessment, Caltrans determined that the Elliot Creek Storm Damage Project:

- May affect, and is likely to adversely affect, the CRLF
- May affect, and is likely to adversely affect, the SFGS
- May affect, but is not likely to adversely affect, the marbled murrelet
- *Will not adversely modify* critical habitat for the CRLF.

5.3 Wetlands and Other Waters Coordination Summary

A wetland and plant survey was completed on January 9, 2017, April 27, 2017, and July 27, 2017. No wetlands were found within Project footprint during surveys. One culverted water feature was identified in the Project footprint that is classified as waters of the U.S.: Elliot Creek (80 linear feet), which is a tributary to the Pacific

Ocean. This section of Elliot Creek is culverted and will be avoided; all work will be done above the bank of Elliot Creek.

5.4 Migratory Bird Treaty Act

MBTA implements international treaties between the United States and other nations devised to protect migratory birds and any of their parts, eggs, and nests from activities such as hunting, pursuing, capturing, killing, selling, and shipping, unless expressly authorized in the regulations or by permit. As authorized by the MBTA, USFWS issues permits to qualified applicants for the following types of activities: falconry, raptor propagation, scientific collecting, special purposes (such as rehabilitation, education, migratory game bird propagation, and salvage), take of depredating birds, taxidermy, and waterfowl sale and disposal. Regulations governing migratory bird permits can be found in 50 CFR, Part 13 General Permit Procedures, and 50 CFR, Part 21 Migratory Bird Permits. While no permits are issued for species protected under codes, coordination with USFWS is required.

5.5 Invasive Species

Executive Order 13112 was signed by President Clinton on February 3, 1999 (*Federal Register* 1999). This executive order directs federal agencies to work to prevent and control the introduction and spread of invasive species, particularly species that are likely to harm the environment, human health, or the economy. The U.S. Department of Transportation (USDOT) plays a large role in the government's fight against invasive species because transportation systems can facilitate the spread of plant and animal species outside their natural range, both domestically and internationally. On April 22, 1999, Secretary of Transportation Rodney E. Slater issued a "Policy Statement on Invasive Alien Species," which directed USDOT's operating administrations to proactively implement Executive Order 13112.

The Federal Highway Administration is active in the effort to control and prevent the spread of invasive species because highway corridors provide opportunities for the movement of invasive species through the landscape. Invasive plant or animal species can move on vehicles and in the loads they carry. Invasive plants can be moved from site to site during spraying and mowing operations. Weed seed can be inadvertently introduced into the corridor during construction on equipment and through the use of mulch, imported soil or gravel, or sod. Some invasive plant species might be deliberately planted in erosion control, landscape, or wildflower projects (USDOT 1999).

In the event that high- or medium-priority noxious weeds, as defined by the California Department of Food and Agriculture or the California Invasive Plant Council, are disturbed or removed during construction-related activities, the contractor will contain the plant material associated with these noxious weeds and dispose of it in a manner that does not promote the spread of the species. The contractor will be responsible for obtaining all permits, licenses, and environmental clearances for properly disposing of materials. Areas subject to noxious weed removal or disturbance will be replanted with fast-growing native grasses or a native erosion control seed mixture. If seeding is not possible, the area should be covered to the extent practicable with heavy black plastic solarization material until the end of the Project.

Chapter 6 References

- Bulger, J.B., N. J. Scott Jr., and R.B. Seymour (Bulger et al.). 2003. Terrestrial activity and conservation of adult California red-legged frogs (*Rana aurora draytonii*) in coastal forests and grasslands. *Biological Conservation* 110:85–95.
- California Department of Fish and Game (CDFG). 2008 (January). Dusky-Footed Woodrat (*Neotoma fuscipes*). Life History Account M127. California Interagency Wildlife Task Group, California Wildlife Habitat Relationships System. Available: <http://www.dfg.ca.gov/biogeodata/cwhr/cawildlife.aspx>. Accessed May 13, 2014.
- California Department of Transportation (Caltrans). 2017. Biological Assessment, Elliot Creek Storm Damage Project. Caltrans District 4. San Mateo County, California. PM 0.3. EA 04-0J210. August 2017.
- California Native Plant Society (CNPS). 2017. Inventory of Rare and Endangered Plants (online edition, v8-02). California Native Plant Society. Sacramento, CA. On the internet at: <http://www.rareplants.cnps.org>. Accessed on July 20, 2017.
- _____. 2017. California Natural Diversity Database (CNDDB). RareFind 5. Wildlife and Habitat Data Analysis Branch. Sacramento, California. Available online at <http://www.dfg.ca.gov/biogeodata/cnddb/mapsanddata.asp>. Accessed on July 20, 2017.
- California Native Plant Society (CNPS). 1995. *CNPS, Monterey Pine Forest Policy*. Originally published March 1995. Available online at http://www.cnps.org/cnps/archive/monterey_pine.pdf
- _____. 2017. *Inventory of Rare and Endangered Plants* (Online Edition, v7-08d). California Native Plant Society. Sacramento, CA. Accessed July 20, 2017. Available online at <http://www.cnps.org/inventory>.
- California State University, Stanislaus. 2014. San Francisco Dusky Footed Woodrat (*Neotoma fuscipes annectens*). In *Endangered, Threatened, and Candidate Species Manual*. Available: <http://esrp.csustan.edu/projects/lsm2/>. Accessed May 5, 2015.

- Carraway, L. N., and B. J. Verts. 1991. *Neotoma fuscipes*. *Mammalian Species* 386:1-10.
- Jennings, Mark R. and Mark P. Hayes. 1988. "Habitat Correlates of Distribution of the California Red-Legged Frog (*Rana aurora draytonii*) and the Foothill Yellow-Legged Frog (*Rana boylei*): Implications for Management." Pages 144-158 In: R. Sarzo, K. E. Severson, and D. R. Patton. *Proceedings of the Symposium on the Management of Amphibians, Reptiles, and Small Mammals in North America*. USDA Forest Service General Technical Report RM-166.
- _____. 1994. *Amphibian and Reptile Species of Concern in California*. California Department of Fish and Game. Inland Fisheries Division. Rancho Cordova, CA. November 1.
- Kelly, P. A. 1990. Population Ecology and Social Organization of Dusky-Footed Woodrats, *Neotoma fuscipes*. PhD dissertation, University of California, Berkeley.
- Meteoblue weather. 2017. Available:
https://www.meteoblue.com/en/weather/forecast/modelclimate/a%C3%B1o-nuevo-state-park_united-states-of-america_5324085. Accessed on June 1, 2017.
- McGinnis, S.M., P. Keel, and E. Burko (McGinnis et al.). 1987. *The use of upland habitats by snake species at Año Nuevo State Reserve*. Prepared for the Department of Parks and Recreation State of California.
- Miles, Scott and Charles Goudey. 1997. *Ecological Subregions of California*. United States Department of Agriculture, Forest Service. Pacific Southwest Division. R5-EM-TP-005-Net. San Francisco, California.
- NMFS. 2017. Species List - Intersection of USGS Topographic Quadrangles with NOAA Fisheries ESU/DPS, Critical Habitat, Species Distribution, and Essential Fish Habitat. January 5, 2017.
- Natural Resources Conservation Service (NRCS). 2017 *Web Soil Inventory*. Available online at
<http://websoilsurvey.nrcs.usda.gov/app/WebSoilSurvey.aspx>.

- _____. 2017b. Official Soil Series Descriptions. Available online at http://www.nrcs.usda.gov/wps/portal/nrcs/detail/soils/survey/geo/?cid=nrcs142p2_053587.
- Santa Cruz Mountains Bioregional Council. 2004. *Sensitive and Poorly Known Mammal Species in the Santa Cruz Mountains Bioregion: Western Pond Turtle* (*Actinemys [=Clemmys] marmorata*). Available at: <http://www.scmhc.net/sensitivereptiles.htm#western>.
- Sawyer et al. 2009. Manual of California Vegetation. A manual of California vegetation. Second Edition. John O. Sawyer, Todd Keeler-Wolf, and Julie M. Evens. 2009. California Native Plant Society, Sacramento, California, USA. 1,300 pages. ISBN 978-0 943460-49-
- Stebbins, R. C. 2003. *A Field Guide to Western Reptiles and Amphibians*. Third Edition. Houghton Mifflin Company, Boston, MA. 533 pp.
- Storer, T.I. 1925. "A synopsis of the amphibia of California." *University of California Publications in Zoology* 27:1-342. In U.S. Fish and Wildlife Service. 2002. *Recovery Plan for the California Red-legged Frog* (*Rana aurora draytonii*). U.S. Fish and Wildlife Service, Portland, Oregon. viii + 173 pp.
- United States Department of Agriculture (NRCS). 2003. NRCS, Plant Guide, Monterey Pine, *Pinus radiata* D. Don. Pgs. 1-4. Available: https://plants.usda.gov/plantguide/pdf/cs_pira2.pdf
- U.S. Department of Transportation (USDOT). 1999. *Policy Statement on Invasive Alien Species*. April 21.
- United States Fish and Wildlife Service (Service). 1992 (September 28). Endangered and Threatened Wildlife and Plants: Determination of threatened status for the Washington, Oregon, and California populations of the marbled murrelet. Federal Register 57:45328.
- _____. 1996 (May 24). Endangered and Threatened Wildlife and Plants: Final designation of critical habitat for the marbled murrelet. Federal Register 61:26256.
- _____. 1997. Recovery plan for the marbled murrelet (Washington, Oregon, and California populations). Portland, Oregon.

- . 2002. Recovery plan for the California red-legged frog (*Rana aurora draytonii*). Portland, OR.
- . 2005 (August). Revised guidance on site assessments and field surveys for the California red-legged frog. Sacramento, CA.
- . 2006 (September). San Francisco garter snake (*Thamnophis sirtalis tetrataenia*) 5-Year Review: Summary and Evaluation. Sacramento Field Office, Sacramento, CA.
- . 2008. “Revised Critical Habitat for the California red-legged frog: Proposed Rule.” *Federal Register* 50: 53492. September 16, 2008.
- . 2010 (March 17). Endangered and Threatened Wildlife and Plants: Revised designation of critical habitat for the California red-legged frog. *Federal Register* 75:12816.
- . 2011 (October 11). Endangered and Threatened Wildlife and Plants: Revised critical habitat for the marbled murrelet. *Federal Register* 61:26256.
- . 2016. *National Wetlands Inventory*. Available online at: <http://www.fws.gov/wetlands/>.
- . 2017. Information for Planning and Consultation (IPAC) System. Available online at: <https://ecos.fws.gov/ipac/>. Accessed July 20, 2017.
- Western Regional Climate Center. 2017. *Period of Record Monthly Climate Summary at Petaluma, California* (046826). Available online at <http://www.wrcc.dri.edu/cgi-bin/cliMAIN.pl?ca6826>.
- Williams, D. F., J. Verner, H. F. Sakai, and J. R. Waters (Williams et al.). 1992. General Biology of Major Prey Species of the California Spotted Owl. U.S. Forest Service General Technical Report PSW-GTR-133:207–221.

Appendix B Photographs of the Project Footprint



Photo 1: View of project site looking north. RSP area to the west of the sag point in the roadway.



Photo 2: View of the sag point in the roadway. Photo taken on 4.27.17.



Photo 3: View of proposed RSP area, looking west. Photo taken on 4.27.17.



Photo 4: View of outfall of culvert and Elliot Creek looking south. This area will not be impacted. RSP located approximately 20 feet above the culvert. Photo taken on 1.9.17.



Photo 5: Looking up at the outfall of Elliot Creek.



Photo 6: Ponded area of Elliot Creek past the outfall on the beach. Photo taken on July 27, 2017.

Appendix C CNDDDB, CNPS, USFWS, and NMFS Species Lists



Selected Elements by Scientific Name

California Department of Fish and Wildlife

California Natural Diversity Database



Query Criteria: Quad (Ano Nuevo (3712213) OR Davenport (3712212) OR Santa Cruz (3612281) OR Pigeon Point (3712224) OR Franklin Point (3712223) OR Big Basin (3712222)) AND (Federal Listing Status IS (Endangered OR Threatened OR Proposed Endangered OR Candidate) OR State Listing Status IS (Endangered OR Threatened OR Candidate Endangered OR Candidate Threatened))

Species	Element Code	Federal Status	State Status	Global Rank	State Rank	Rare Plant Rank/CDFW SSC or FP
<i>Agelaius tricolor</i> tricolored blackbird	ABPBXB0020	None	Candidate Endangered	G2G3	S1S2	SSC
<i>Arenaria paludicola</i> marsh sandwort	PDCAR040L0	Endangered	Endangered	G1	S1	1B.1
<i>Brachyramphus marmoratus</i> marbled murrelet	ABNNN06010	Threatened	Endangered	G3G4	S1	
<i>Charadrius alexandrinus nivosus</i> western snowy plover	ABNNB03031	Threatened	None	G3T3	S2S3	SSC
<i>Chorizanthe pungens var. hartwegiana</i> Ben Lomond spineflower	PDPGN040M1	Endangered	None	G2T1	S1	1B.1
<i>Chorizanthe robusta var. robusta</i> robust spineflower	PDPGN040Q2	Endangered	None	G2T1	S1	1B.1
<i>Cicindela ohlone</i> Ohlone tiger beetle	IICOL026L0	Endangered	None	G1	S1	
<i>Erysimum teretifolium</i> Santa Cruz wallflower	PDBRA160N0	Endangered	Endangered	G1	S1	1B.1
<i>Eucyclogobius newberryi</i> tidewater goby	AFCQN04010	Endangered	None	G3	S3	SSC
<i>Hesperocyparis abramsiana var. abramsiana</i> Santa Cruz cypress	PGCUP04081	Threatened	Endangered	G1T1	S1	1B.2
<i>Hesperocyparis abramsiana var. butanoensis</i> Butano Ridge cypress	PGCUP04082	Threatened	Endangered	G1T1	S1	1B.2
<i>Holocarpha macradenia</i> Santa Cruz tarplant	PDAST4X020	Threatened	Endangered	G1	S1	1B.1
<i>Laterallus jamaicensis coturniculus</i> California black rail	ABNME03041	None	Threatened	G3G4T1	S1	FP
<i>Limnanthes douglasii ssp. sulphurea</i> Point Reyes meadowfoam	PDLIM02038	None	Endangered	G4T1	S1	1B.2
<i>Oncorhynchus kisutch</i> coho salmon - central California coast ESU	AFCHA02034	Endangered	Endangered	G4	S2?	
<i>Oncorhynchus mykiss irideus</i> steelhead - central California coast DPS	AFCHA0209G	Threatened	None	G5T2T3Q	S2S3	
<i>Pentachaeta bellidiflora</i> white-rayed pentachaeta	PDAST6X030	Endangered	Endangered	G1	S1	1B.1
<i>Plagiobothrys diffusus</i> San Francisco popcornflower	PDBOR0V080	None	Endangered	G1Q	S1	1B.1



Selected Elements by Scientific Name
California Department of Fish and Wildlife
California Natural Diversity Database



Species	Element Code	Federal Status	State Status	Global Rank	State Rank	Rare Plant Rank/CDFW SSC or FP
<i>Rana draytonii</i> California red-legged frog	AAABH01022	Threatened	None	G2G3	S2S3	SSC
<i>Riparia riparia</i> bank swallow	ABPAU08010	None	Threatened	G5	S2	
<i>Speyeria zerene myrtleae</i> Myrtle's silverspot butterfly	IILEPJ608C	Endangered	None	G5T1	S1	
<i>Spirinchus thaleichthys</i> longfin smelt	AFCHB03010	Candidate	Threatened	G5	S1	SSC
<i>Thamnophis sirtalis tetrataenia</i> San Francisco gartersnake	ARADB3613B	Endangered	Endangered	G5T2Q	S2	FP
<i>Trimerotropis infantilis</i> Zayante band-winged grasshopper	IIORT36030	Endangered	None	G1	S1	

Record Count: 24



Selected Elements by Scientific Name

California Department of Fish and Wildlife

California Natural Diversity Database



Query Criteria: Quad (Ano Nuevo (3712213) OR Davenport (3712212) OR Santa Cruz (3612281) OR Pigeon Point (3712224) OR Franklin Point (3712223) OR Big Basin (3712222)) AND Other Status Contains (CDFW_FP-Fully Protected OR CDFW_SSC-Species of Special Concern OR NMFS_SC-Species of Concern)

Table with 7 columns: Species, Element Code, Federal Status, State Status, Global Rank, State Rank, Rare Plant Rank/CDFW SSC or FP. Rows include species like Agelaius tricolor, Aneides niger, Athene cunicularia, etc.

Record Count: 16



Selected Elements by Scientific Name

California Department of Fish and Wildlife

California Natural Diversity Database



Query Criteria: Quad IS (Ano Nuevo (3712213) OR Davenport (3712212) OR Santa Cruz (3612281) OR Pigeon Point (3712224) OR Franklin Point (3712223) OR Big Basin (3712222))
 AND CNPS List IS (1A OR 1B OR 1B.1 OR 1B.2 OR 1B.3 OR 2A OR 2B OR 2B.1 OR 2B.2 OR 2B.3)

Species	Element Code	Federal Status	State Status	Global Rank	State Rank	Rare Plant Rank/CDFW SSC or FP
<i>Agrostis blasdalei</i> Blasdale's bent grass	PMPOA04060	None	None	G2	S2	1B.2
<i>Amsinckia lunaris</i> bent-flowered fiddleneck	PDBOR01070	None	None	G2G3	S2S3	1B.2
<i>Arctostaphylos andersonii</i> Anderson's manzanita	PDERI04030	None	None	G2	S2	1B.2
<i>Arctostaphylos glutinosa</i> Schreiber's manzanita	PDERI040G0	None	None	G1	S1	1B.2
<i>Arctostaphylos ohloneana</i> Ohlone manzanita	PDERI042Y0	None	None	G1	S1	1B.1
<i>Arctostaphylos regismontana</i> Kings Mountain manzanita	PDERI041C0	None	None	G2	S2	1B.2
<i>Arctostaphylos silvicola</i> Bonny Doon manzanita	PDERI041F0	None	None	G1	S1	1B.2
<i>Arenaria paludicola</i> marsh sandwort	PDCAR040L0	Endangered	Endangered	G1	S1	1B.1
<i>Astragalus pycnostachyus var. pycnostachyus</i> coastal marsh milk-vetch	PDFAB0F7B2	None	None	G2T2	S2	1B.2
<i>California macrophylla</i> round-leaved filaree	PDGER01070	None	None	G3?	S3?	1B.2
<i>Calyptridium parryi var. hesseae</i> Santa Cruz Mountains pussypaws	PDPOR09052	None	None	G3G4T2	S2	1B.1
<i>Chorizanthe pungens var. hartwegiana</i> Ben Lomond spineflower	PDPGN040M1	Endangered	None	G2T1	S1	1B.1
<i>Chorizanthe robusta var. robusta</i> robust spineflower	PDPGN040Q2	Endangered	None	G2T1	S1	1B.1
<i>Cirsium andrewsii</i> Franciscan thistle	PDAST2E050	None	None	G3	S3	1B.2
<i>Collinsia multicolor</i> San Francisco collinsia	PDSCR0H0B0	None	None	G2	S2	1B.2
<i>Dacryophyllum falcifolium</i> tear drop moss	NBMUS8Z010	None	None	G2	S2	1B.3
<i>Erysimum ammophilum</i> sand-loving wallflower	PDBRA16010	None	None	G2	S2	1B.2
<i>Erysimum teretifolium</i> Santa Cruz wallflower	PDBRA160N0	Endangered	Endangered	G1	S1	1B.1



Selected Elements by Scientific Name
California Department of Fish and Wildlife
California Natural Diversity Database



Species	Element Code	Federal Status	State Status	Global Rank	State Rank	Rare Plant Rank/CDFW SSC or FP
<i>Fissidens pauperculus</i> minute pocket moss	NBMUS2W0U0	None	None	G3?	S2	1B.2
<i>Fritillaria liliacea</i> fragrant fritillary	PMLIL0V0C0	None	None	G2	S2	1B.2
<i>Grimmia torenii</i> Toren's grimmia	NBMUS32330	None	None	G2	S2	1B.3
<i>Grimmia vaginulata</i> vaginulate grimmia	NBMUS32340	None	None	G2G3	S1	1B.1
<i>Hesperevax sparsiflora</i> var. <i>brevifolia</i> short-leaved evax	PDASTE5011	None	None	G4T3	S2	1B.2
<i>Hesperocyparis abramsiana</i> var. <i>abramsiana</i> Santa Cruz cypress	PGCUP04081	Threatened	Endangered	G1T1	S1	1B.2
<i>Hesperocyparis abramsiana</i> var. <i>butanoensis</i> Butano Ridge cypress	PGCUP04082	Threatened	Endangered	G1T1	S1	1B.2
<i>Holocarpha macradenia</i> Santa Cruz tarplant	PDAST4X020	Threatened	Endangered	G1	S1	1B.1
<i>Horkelia cuneata</i> var. <i>sericea</i> Kellogg's horkelia	PDR0S0W043	None	None	G4T1?	S1?	1B.1
<i>Horkelia marinensis</i> Point Reyes horkelia	PDR0S0W0B0	None	None	G2	S2	1B.2
<i>Lasthenia californica</i> ssp. <i>macrantha</i> perennial goldfields	PDAST5L0C5	None	None	G3T2	S2	1B.2
<i>Leptosiphon rosaceus</i> rose leptosiphon	PDPLM09180	None	None	G1	S1	1B.1
<i>Limnanthes douglasii</i> ssp. <i>sulphurea</i> Point Reyes meadowfoam	PDLIM02038	None	Endangered	G4T1	S1	1B.2
<i>Malacothamnus arcuatus</i> arcuate bush-mallow	PDMAL0Q0E0	None	None	G2Q	S2	1B.2
<i>Microseris paludosa</i> marsh microseris	PDAST6E0D0	None	None	G2	S2	1B.2
<i>Monolopia gracilens</i> woodland woollythreads	PDAST6G010	None	None	G3	S3	1B.2
<i>Orthotrichum kellmanii</i> Kellman's bristle moss	NBMUS56190	None	None	G2	S2	1B.2
<i>Pedicularis dudleyi</i> Dudley's lousewort	PDSCR1K0D0	None	Rare	G2	S2	1B.2
<i>Penstemon rattanii</i> var. <i>kleei</i> Santa Cruz Mountains beardtongue	PDSCR1L5B1	None	None	G4T2	S2	1B.2
<i>Pentachaeta bellidiflora</i> white-rayed pentachaeta	PDAST6X030	Endangered	Endangered	G1	S1	1B.1
<i>Pinus radiata</i> Monterey pine	PGPIN040V0	None	None	G1	S1	1B.1



Selected Elements by Scientific Name
California Department of Fish and Wildlife
California Natural Diversity Database



Species	Element Code	Federal Status	State Status	Global Rank	State Rank	Rare Plant Rank/CDFW SSC or FP
<i>Piperia candida</i> white-flowered rein orchid	PMORC1X050	None	None	G3	S3	1B.2
<i>Plagiobothrys chorisianus var. chorisianus</i> Choris' popcornflower	PDBOR0V061	None	None	G3T2Q	S2	1B.2
<i>Plagiobothrys diffusus</i> San Francisco popcornflower	PDBOR0V080	None	Endangered	G1Q	S1	1B.1
<i>Rosa pinetorum</i> pine rose	PDR0S1J0W0	None	None	G2	S2	1B.2
<i>Senecio aphanactis</i> chaparral ragwort	PDAST8H060	None	None	G3	S2	2B.2
<i>Silene verecunda ssp. verecunda</i> San Francisco campion	PDCAR0U213	None	None	G5T2	S2	1B.2
<i>Stebbinsoseris decipiens</i> Santa Cruz microseris	PDAST6E050	None	None	G2	S2	1B.2
<i>Stuckenia filiformis ssp. alpina</i> slender-leaved pondweed	PM POT03091	None	None	G5T5	S3	2B.2
<i>Trifolium buckwestiorum</i> Santa Cruz clover	PDFAB402W0	None	None	G2	S2	1B.1

Record Count: 48



Plant List

Inventory of Rare and Endangered Plants

4 matches found. *Click on scientific name for details*

Search Criteria

California Rare Plant Rank is one of [1A, 1B, 2A, 2B],
FESA is one of [Endangered, Threatened, Candidate], CESA is one of [Endangered, Threatened], Found
in Quads 3712224, 3712223, 3712222 3712213 and 3712212;

[Modify Search Criteria](#) [Export to Excel](#) [Modify Columns](#) [Modify Sort](#) [Display Photos](#)

Scientific Name	Common Name	Family	Lifeform	Blooming Period	CA Rare Plant Rank	State Rank	Global Rank
Erysimum teretifolium	Santa Cruz wallflower	Brassicaceae	perennial herb	Mar-Jul	1B.1	S1	G1
Hesperocyparis abramsiana var. abramsiana	Santa Cruz cypress	Cupressaceae	perennial evergreen tree		1B.2	S1	G1T1
Hesperocyparis abramsiana var. butanoensis	Butano Ridge cypress	Cupressaceae	perennial evergreen tree	Oct	1B.2	S1	G1T1
Pentachaeta bellidiflora	white-rayed pentachaeta	Asteraceae	annual herb	Mar-May	1B.1	S1	G1

Suggested Citation

California Native Plant Society, Rare Plant Program. 2017. Inventory of Rare and Endangered Plants of California (online edition, v8-03 0.39). Website <http://www.rareplants.cnps.org> [accessed 20 July 2017].

Search the Inventory

[Simple Search](#)

[Advanced Search](#)

[Glossary](#)

Information

[About the Inventory](#)

[About the Rare Plant Program](#)

[CNPS Home Page](#)

[About CNPS](#)

[Join CNPS](#)

Contributors

[The Calflora Database](#)

[The California Lichen Society](#)



United States Department of the Interior



FISH AND WILDLIFE SERVICE
Sacramento Fish And Wildlife Office
Federal Building
2800 Cottage Way, Room W-2605
Sacramento, CA 95825-1846
Phone: (916) 414-6600 Fax: (916) 414-6713

In Reply Refer To:

July 20, 2017

Consultation Code: 08ESMF00-2017-SLI-2659

Event Code: 08ESMF00-2017-E-07297

Project Name: Elliot Creek Storm Damage Repair Project

Subject: List of threatened and endangered species that may occur in your proposed project location, and/or may be affected by your proposed project

To Whom It May Concern:

The enclosed species list identifies threatened, endangered, proposed and candidate species, as well as proposed and final designated critical habitat, under the jurisdiction of the U.S. Fish and Wildlife Service (Service) that may occur within the boundary of your proposed project and/or may be affected by your proposed project. The species list fulfills the requirements of the Service under section 7(c) of the Endangered Species Act (Act) of 1973, as amended (16 U.S.C. 1531 et seq.).

Please follow the link below to see if your proposed project has the potential to affect other species or their habitats under the jurisdiction of the National Marine Fisheries Service:

http://www.nwr.noaa.gov/protected_species/species_list/species_lists.html

New information based on updated surveys, changes in the abundance and distribution of species, changed habitat conditions, or other factors could change this list. Please feel free to contact us if you need more current information or assistance regarding the potential impacts to federally proposed, listed, and candidate species and federally designated and proposed critical habitat. Please note that under 50 CFR 402.12(e) of the regulations implementing section 7 of the Act, the accuracy of this species list should be verified after 90 days. This verification can be completed formally or informally as desired. The Service recommends that verification be completed by visiting the ECOS-IPaC website at regular intervals during project planning and implementation for updates to species lists and information. An updated list may be requested through the ECOS-IPaC system by completing the same process used to receive the enclosed list.

The purpose of the Act is to provide a means whereby threatened and endangered species and the ecosystems upon which they depend may be conserved. Under sections 7(a)(1) and 7(a)(2) of the Act and its implementing regulations (50 CFR 402 et seq.), Federal agencies are required to

utilize their authorities to carry out programs for the conservation of threatened and endangered species and to determine whether projects may affect threatened and endangered species and/or designated critical habitat.

A Biological Assessment is required for construction projects (or other undertakings having similar physical impacts) that are major Federal actions significantly affecting the quality of the human environment as defined in the National Environmental Policy Act (42 U.S.C. 4332(2) (c)). For projects other than major construction activities, the Service suggests that a biological evaluation similar to a Biological Assessment be prepared to determine whether the project may affect listed or proposed species and/or designated or proposed critical habitat. Recommended contents of a Biological Assessment are described at 50 CFR 402.12.

If a Federal agency determines, based on the Biological Assessment or biological evaluation, that listed species and/or designated critical habitat may be affected by the proposed project, the agency is required to consult with the Service pursuant to 50 CFR 402. In addition, the Service recommends that candidate species, proposed species and proposed critical habitat be addressed within the consultation. More information on the regulations and procedures for section 7 consultation, including the role of permit or license applicants, can be found in the "Endangered Species Consultation Handbook" at:

<http://www.fws.gov/endangered/esa-library/pdf/TOC-GLOS.PDF>

Please be aware that bald and golden eagles are protected under the Bald and Golden Eagle Protection Act (16 U.S.C. 668 et seq.), and projects affecting these species may require development of an eagle conservation plan (http://www.fws.gov/windenergy/eagle_guidance.html). Additionally, wind energy projects should follow the wind energy guidelines (<http://www.fws.gov/windenergy/>) for minimizing impacts to migratory birds and bats.

Guidance for minimizing impacts to migratory birds for projects including communications towers (e.g., cellular, digital television, radio, and emergency broadcast) can be found at: <http://www.fws.gov/migratorybirds/CurrentBirdIssues/Hazards/towers/towers.htm>; <http://www.towerkill.com>; and <http://www.fws.gov/migratorybirds/CurrentBirdIssues/Hazards/towers/comtow.html>.

We appreciate your concern for threatened and endangered species. The Service encourages Federal agencies to include conservation of threatened and endangered species into their project planning to further the purposes of the Act. Please include the Consultation Tracking Number in the header of this letter with any request for consultation or correspondence about your project that you submit to our office.

Attachment(s):

- Official Species List
-

Official Species List

This list is provided pursuant to Section 7 of the Endangered Species Act, and fulfills the requirement for Federal agencies to "request of the Secretary of the Interior information whether any species which is listed or proposed to be listed may be present in the area of a proposed action".

This species list is provided by:

Sacramento Fish And Wildlife Office

Federal Building

2800 Cottage Way, Room W-2605

Sacramento, CA 95825-1846

(916) 414-6600

This project's location is within the jurisdiction of multiple offices. Expect additional species list documents from the following office:

Ventura Fish And Wildlife Office

2493 Portola Road, Suite B

Ventura, CA 93003-7726

(805) 644-1766

Project Summary

Consultation Code: 08ESMF00-2017-SLI-2659
Event Code: 08ESMF00-2017-E-07297
Project Name: Elliot Creek Storm Damage Repair Project
Project Type: TRANSPORTATION
Project Description: San Mateo Hwy 1 PM 0.3

Project Location:

Approximate location of the project can be viewed in Google Maps:

<https://www.google.com/maps/place/37.063290282196135N122.31553211667025W>



Counties: San Mateo, CA | Santa Cruz, CA

Endangered Species Act Species

There is a total of 16 threatened, endangered, or candidate species on your species list. Species on this list should be considered in an effects analysis for your project and could include species that exist in another geographic area. For example, certain fish may appear on the species list because a project could affect downstream species. See the "Critical habitats" section below for those critical habitats that lie wholly or partially within your project area. Please contact the designated FWS office if you have questions.

Mammals

NAME	STATUS
Southern Sea Otter (<i>Enhydra lutris nereis</i>) No critical habitat has been designated for this species. Species profile: https://ecos.fws.gov/ecp/species/8560	Threatened

Birds

NAME	STATUS
California Least Tern (<i>Sterna antillarum browni</i>) No critical habitat has been designated for this species. Species profile: https://ecos.fws.gov/ecp/species/8104	Endangered
Marbled Murrelet (<i>Brachyramphus marmoratus</i>) Population: U.S.A. (CA, OR, WA) There is a final critical habitat designated for this species. Your location overlaps the designated critical habitat. Species profile: https://ecos.fws.gov/ecp/species/4467	Threatened
Short-tailed Albatross (<i>Phoebastria (=Diomedea) albatrus</i>) No critical habitat has been designated for this species. Species profile: https://ecos.fws.gov/ecp/species/433	Endangered
Western Snowy Plover (<i>Charadrius alexandrinus nivosus</i>) Population: Pacific Coast population DPS-U.S.A. (CA, OR, WA), Mexico (within 50 miles of Pacific coast) There is a final critical habitat designated for this species. Your location overlaps the designated critical habitat. Species profile: https://ecos.fws.gov/ecp/species/8035	Threatened

Reptiles

NAME	STATUS
Green Sea Turtle (<i>Chelonia mydas</i>) Population: East Pacific DPS No critical habitat has been designated for this species. Species profile: https://ecos.fws.gov/ecp/species/6199	Threatened
San Francisco Garter Snake (<i>Thamnophis sirtalis tetrataenia</i>) No critical habitat has been designated for this species. Species profile: https://ecos.fws.gov/ecp/species/5956	Endangered

Amphibians

NAME	STATUS
<p>California Red-legged Frog (<i>Rana draytonii</i>)</p> <p>There is a final critical habitat designated for this species. Your location overlaps the designated critical habitat.</p> <p>Species profile: https://ecos.fws.gov/ecp/species/2891</p>	Threatened
<p>California Tiger Salamander (<i>Ambystoma californiense</i>)</p> <p>Population: U.S.A. (Central CA DPS)</p> <p>There is a final critical habitat designated for this species. Your location is outside the designated critical habitat.</p> <p>Species profile: https://ecos.fws.gov/ecp/species/2076</p>	Threatened

Fishes

NAME	STATUS
<p>Delta Smelt (<i>Hypomesus transpacificus</i>)</p> <p>There is a final critical habitat designated for this species. Your location is outside the designated critical habitat.</p> <p>Species profile: https://ecos.fws.gov/ecp/species/321</p>	Threatened
<p>Steelhead (<i>Oncorhynchus (=Salmo) mykiss</i>)</p> <p>Population: Northern California DPS</p> <p>There is a final critical habitat designated for this species. Your location overlaps the designated critical habitat.</p> <p>Species profile: https://ecos.fws.gov/ecp/species/1007</p>	Threatened
<p>Tidewater Goby (<i>Eucyclogobius newberryi</i>)</p> <p>There is a final critical habitat designated for this species. Your location overlaps the designated critical habitat.</p> <p>Species profile: https://ecos.fws.gov/ecp/species/57</p>	Endangered

Insects

NAME	STATUS
<p>San Bruno Elfin Butterfly (<i>Callophrys mossii bayensis</i>)</p> <p>No critical habitat has been designated for this species.</p> <p>Species profile: https://ecos.fws.gov/ecp/species/3394</p>	Endangered

Flowering Plants

NAME	STATUS
Ben Lomond Spineflower (<i>Chorizanthe pungens</i> var. <i>hartwegiana</i>) No critical habitat has been designated for this species. Species profile: https://ecos.fws.gov/ecp/species/7498	Endangered
Ben Lomond Wallflower (<i>Erysimum teretifolium</i>) No critical habitat has been designated for this species. Species profile: https://ecos.fws.gov/ecp/species/7429	Endangered

Conifers and Cycads

NAME	STATUS
Santa Cruz Cypress (<i>Cupressus abramsiana</i>) No critical habitat has been designated for this species. Species profile: https://ecos.fws.gov/ecp/species/1678	Threatened

Critical habitats

There are 5 critical habitats wholly or partially within your project area.

NAME	STATUS
California Red-legged Frog (<i>Rana draytonii</i>)	Final designated
Marbled Murrelet (<i>Brachyramphus marmoratus</i>)	Final designated
Steelhead (<i>Oncorhynchus</i> (= <i>Salmo</i>) <i>mykiss</i>)	Final designated
Tidewater Goby (<i>Eucyclogobius newberryi</i>)	Final designated
Western Snowy Plover (<i>Charadrius alexandrinus nivosus</i>)	Final designated



United States Department of the Interior



FISH AND WILDLIFE SERVICE

Ventura Fish And Wildlife Office

2493 Portola Road, Suite B

Ventura, CA 93003-7726

Phone: (805) 644-1766 Fax: (805) 644-3958

In Reply Refer To:

July 20, 2017

Consultation Code: 08EVEN00-2017-SLI-0543

Event Code: 08EVEN00-2017-E-01191

Project Name: Elliot Creek Storm Damage Repair Project

Subject: List of threatened and endangered species that may occur in your proposed project location, and/or may be affected by your proposed project

To Whom It May Concern:

The enclosed list identifies species listed as threatened and endangered, species proposed for listing as threatened or endangered, designated and proposed critical habitat, and species that are candidates for listing that may occur within the boundary of the area you have indicated using the U.S. Fish and Wildlife Service's (Service) Information Planning and Conservation System (IPaC). The species list fulfills the requirements under section 7(c) of the Endangered Species Act (Act) of 1973, as amended (16 U.S.C. 1531 et seq.). Please note that under 50 CFR 402.12(e) of the regulations implementing section 7 of the Act, the species list should be verified after 90 days. We recommend that verification be completed by visiting the IPaC website at regular intervals during project planning and implementation for updates to species lists following the same process you used to receive the enclosed list. Please include the Consultation Tracking Number in the header of this letter with any correspondence about the species list.

Due to staff shortages and excessive workload, we are unable to provide an official list more specific to your area. Numerous other sources of information are available for you to narrow the list to the habitats and conditions of the site in which you are interested. For example, we recommend conducting a biological site assessment or surveys for plants and animals that could help refine the list.

If a Federal agency is involved in the project, that agency has the responsibility to review its proposed activities and determine whether any listed species may be affected. If the project is a major construction project*, the Federal agency has the responsibility to prepare a biological assessment to make a determination of the effects of the action on the listed species or critical habitat. If the Federal agency determines that a listed species or critical habitat is likely to be adversely affected, it should request, in writing through our office, formal consultation pursuant to section 7 of the Act. Informal consultation may be used to exchange information and resolve conflicts with respect to threatened or endangered species or their critical habitat prior to a

written request for formal consultation. During this review process, the Federal agency may engage in planning efforts but may not make any irreversible commitment of resources. Such a commitment could constitute a violation of section 7(d) of the Act.

Federal agencies are required to confer with the Service, pursuant to section 7(a)(4) of the Act, when an agency action is likely to jeopardize the continued existence of any proposed species or result in the destruction or adverse modification of proposed critical habitat (50 CFR 402.10(a)). A request for formal conference must be in writing and should include the same information that would be provided for a request for formal consultation. Conferences can also include discussions between the Service and the Federal agency to identify and resolve potential conflicts between an action and proposed species or proposed critical habitat early in the decision-making process. The Service recommends ways to minimize or avoid adverse effects of the action. These recommendations are advisory because the jeopardy prohibition of section 7(a)(2) of the Act does not apply until the species is listed or the proposed critical habitat is designated. The conference process fulfills the need to inform Federal agencies of possible steps that an agency might take at an early stage to adjust its actions to avoid jeopardizing a proposed species.

When a proposed species or proposed critical habitat may be affected by an action, the lead Federal agency may elect to enter into formal conference with the Service even if the action is not likely to jeopardize or result in the destruction or adverse modification of proposed critical habitat. If the proposed species is listed or the proposed critical habitat is designated after completion of the conference, the Federal agency may ask the Service, in writing, to confirm the conference as a formal consultation. If the Service reviews the proposed action and finds that no significant changes in the action as planned or in the information used during the conference have occurred, the Service will confirm the conference as a formal consultation on the project and no further section 7 consultation will be necessary. Use of the formal conference process in this manner can prevent delays in the event the proposed species is listed or the proposed critical habitat is designated during project development or implementation.

Candidate species are those species presently under review by the Service for consideration for Federal listing. Candidate species should be considered in the planning process because they may become listed or proposed for listing prior to project completion. Preparation of a biological assessment, as described in section 7(c) of the Act, is not required for candidate species. If early evaluation of your project indicates that it is likely to affect a candidate species, you may wish to request technical assistance from this office.

Only listed species receive protection under the Act. However, sensitive species should be considered in the planning process in the event they become listed or proposed for listing prior to project completion. We recommend that you review information in the California Department of Fish and Wildlife's Natural Diversity Data Base. You can contact the California Department of Fish and Wildlife at (916) 324-3812 for information on other sensitive species that may occur in this area.

[*A Biological Assessment is required for construction projects (or other undertakings having

similar physical impacts) that are major Federal actions significantly affecting the quality of the human environment as defined in the National Environmental Policy Act (42 U.S.C. 4332(2)(c)). For projects other than major construction activities, the Service suggests that a biological evaluation similar to a Biological Assessment be prepared to determine whether the project may affect listed or proposed species and/or designated or proposed critical habitat. Recommended contents of a Biological Assessment are described at 50 CFR 402.12.]

Attachment(s):

- Official Species List

Official Species List

This list is provided pursuant to Section 7 of the Endangered Species Act, and fulfills the requirement for Federal agencies to "request of the Secretary of the Interior information whether any species which is listed or proposed to be listed may be present in the area of a proposed action".

This species list is provided by:

Ventura Fish And Wildlife Office

2493 Portola Road, Suite B
Ventura, CA 93003-7726
(805) 644-1766

This project's location is within the jurisdiction of multiple offices. Expect additional species list documents from the following office:

Sacramento Fish And Wildlife Office

Federal Building
2800 Cottage Way, Room W-2605
Sacramento, CA 95825-1846
(916) 414-6600

Project Summary

Consultation Code: 08EVEN00-2017-SLI-0543
Event Code: 08EVEN00-2017-E-01191
Project Name: Elliot Creek Storm Damage Repair Project
Project Type: TRANSPORTATION
Project Description: San Mateo Hwy 1 PM 0.3

Project Location:

Approximate location of the project can be viewed in Google Maps:

<https://www.google.com/maps/place/37.063290282196135N122.31553211667025W>



Counties: San Mateo, CA | Santa Cruz, CA

Endangered Species Act Species

There is a total of 22 threatened, endangered, or candidate species on your species list. Species on this list should be considered in an effects analysis for your project and could include species that exist in another geographic area. For example, certain fish may appear on the species list because a project could affect downstream species. See the "Critical habitats" section below for those critical habitats that lie wholly or partially within your project area. Please contact the designated FWS office if you have questions.

Mammals

NAME	STATUS
Southern Sea Otter (<i>Enhydra lutris nereis</i>) No critical habitat has been designated for this species. Species profile: https://ecos.fws.gov/ecp/species/8560	Threatened

Birds

NAME	STATUS
California Least Tern (<i>Sterna antillarum browni</i>) No critical habitat has been designated for this species. Species profile: https://ecos.fws.gov/ecp/species/8104	Endangered
Least Bell's Vireo (<i>Vireo bellii pusillus</i>) There is a final critical habitat designated for this species. Your location is outside the designated critical habitat. Species profile: https://ecos.fws.gov/ecp/species/5945	Endangered
Marbled Murrelet (<i>Brachyramphus marmoratus</i>) Population: U.S.A. (CA, OR, WA) There is a final critical habitat designated for this species. Your location overlaps the designated critical habitat. Species profile: https://ecos.fws.gov/ecp/species/4467	Threatened
Southwestern Willow Flycatcher (<i>Empidonax traillii extimus</i>) There is a final critical habitat designated for this species. Your location is outside the designated critical habitat. Species profile: https://ecos.fws.gov/ecp/species/6749	Endangered
Western Snowy Plover (<i>Charadrius alexandrinus nivosus</i>) Population: Pacific Coast population DPS-U.S.A. (CA, OR, WA), Mexico (within 50 miles of Pacific coast) There is a final critical habitat designated for this species. Your location overlaps the designated critical habitat. Species profile: https://ecos.fws.gov/ecp/species/8035	Threatened

Reptiles

NAME	STATUS
San Francisco Garter Snake (<i>Thamnophis sirtalis tetrataenia</i>) No critical habitat has been designated for this species. Species profile: https://ecos.fws.gov/ecp/species/5956	Endangered

Amphibians

NAME	STATUS
<p>California Red-legged Frog (<i>Rana draytonii</i>)</p> <p>There is a final critical habitat designated for this species. Your location overlaps the designated critical habitat.</p> <p>Species profile: https://ecos.fws.gov/ecp/species/2891</p>	Threatened
<p>California Tiger Salamander (<i>Ambystoma californiense</i>)</p> <p>Population: U.S.A. (Central CA DPS)</p> <p>There is a final critical habitat designated for this species. Your location is outside the designated critical habitat.</p> <p>Species profile: https://ecos.fws.gov/ecp/species/2076</p>	Threatened

Fishes

NAME	STATUS
<p>Tidewater Goby (<i>Eucyclogobius newberryi</i>)</p> <p>There is a final critical habitat designated for this species. Your location overlaps the designated critical habitat.</p> <p>Species profile: https://ecos.fws.gov/ecp/species/57</p>	Endangered

Insects

NAME	STATUS
<p>Mount Hermon June Beetle (<i>Polyphylla barbata</i>)</p> <p>No critical habitat has been designated for this species.</p> <p>Species profile: https://ecos.fws.gov/ecp/species/3982</p>	Endangered
<p>Ohlone Tiger Beetle (<i>Cicindela ohlone</i>)</p> <p>No critical habitat has been designated for this species.</p> <p>Species profile: https://ecos.fws.gov/ecp/species/8271</p>	Endangered
<p>Smith's Blue Butterfly (<i>Euphilotes enoptes smithi</i>)</p> <p>No critical habitat has been designated for this species.</p> <p>Species profile: https://ecos.fws.gov/ecp/species/4418</p>	Endangered
<p>Zayante Band-winged Grasshopper (<i>Trimerotropis infantilis</i>)</p> <p>There is a final critical habitat designated for this species. Your location is outside the designated critical habitat.</p> <p>Species profile: https://ecos.fws.gov/ecp/species/1036</p>	Endangered

Flowering Plants

NAME	STATUS
<p>Ben Lomond Spineflower (<i>Chorizanthe pungens</i> var. <i>hartwegiana</i>) No critical habitat has been designated for this species. Species profile: https://ecos.fws.gov/ecp/species/7498</p>	Endangered
<p>Ben Lomond Wallflower (<i>Erysimum teretifolium</i>) No critical habitat has been designated for this species. Species profile: https://ecos.fws.gov/ecp/species/7429</p>	Endangered
<p>Marsh Sandwort (<i>Arenaria paludicola</i>) No critical habitat has been designated for this species. Species profile: https://ecos.fws.gov/ecp/species/2229</p>	Endangered
<p>Menzies' Wallflower (<i>Erysimum menziesii</i>) No critical habitat has been designated for this species. Species profile: https://ecos.fws.gov/ecp/species/2935</p>	Endangered
<p>Santa Cruz Tarplant (<i>Holocarpha macradenia</i>) There is a final critical habitat designated for this species. Your location overlaps the designated critical habitat. Species profile: https://ecos.fws.gov/ecp/species/6832</p>	Threatened
<p>Scotts Valley Polygonum (<i>Polygonum hickmanii</i>) There is a final critical habitat designated for this species. Your location is outside the designated critical habitat. Species profile: https://ecos.fws.gov/ecp/species/3222</p>	Endangered
<p>Scotts Valley Spineflower (<i>Chorizanthe robusta</i> var. <i>hartwegii</i>) There is a final critical habitat designated for this species. Your location is outside the designated critical habitat. Species profile: https://ecos.fws.gov/ecp/species/7108</p>	Endangered

Conifers and Cycads

NAME	STATUS
<p>Santa Cruz Cypress (<i>Cupressus abramsiana</i>) No critical habitat has been designated for this species. Species profile: https://ecos.fws.gov/ecp/species/1678</p>	Threatened

Critical habitats

There are 5 critical habitats wholly or partially within your project area.

NAME	STATUS
California Red-legged Frog (<i>Rana draytonii</i>)	Final designated
Marbled Murrelet (<i>Brachyramphus marmoratus</i>)	Final designated
Santa Cruz Tarplant (<i>Holocarpha macradenia</i>)	Final designated
Tidewater Goby (<i>Eucyclogobius newberryi</i>)	Final designated
Western Snowy Plover (<i>Charadrius alexandrinus nivosus</i>)	Final designated

Elliot Creek Storm Damage Project
Official NMFS Species List for 6 Quadrangles
January 5, 2017 and June 14, 2017

Quad Name **Ano Nuevo ***

Quad Number **37122-A3**

ESA Anadromous Fish

SONCC Coho ESU (T) -
CCC Coho ESU (E) - **X**
CC Chinook Salmon ESU (T) -
CVSR Chinook Salmon ESU (T) -
SRWR Chinook Salmon ESU (E) -
NC Steelhead DPS (T) -
CCC Steelhead DPS (T) - **X**
SCCC Steelhead DPS (T) -
SC Steelhead DPS (E) -
CCV Steelhead DPS (T) -
Eulachon (T) -
sDPS Green Sturgeon (T) - **X**

ESA Anadromous Fish Critical Habitat

SONCC Coho Critical Habitat -
CCC Coho Critical Habitat - **X**
CC Chinook Salmon Critical Habitat -
CVSR Chinook Salmon Critical Habitat -
SRWR Chinook Salmon Critical Habitat -
NC Steelhead Critical Habitat -
CCC Steelhead Critical Habitat - **X**
SCCC Steelhead Critical Habitat -
SC Steelhead Critical Habitat -
CCV Steelhead Critical Habitat -

Eulachon Critical Habitat -
sDPS Green Sturgeon Critical Habitat - **X**

ESA Marine Invertebrates

Range Black Abalone (E) - **X**
Range White Abalone (E) -

ESA Marine Invertebrates Critical Habitat

Black Abalone Critical Habitat - **X**

ESA Sea Turtles

East Pacific Green Sea Turtle (T) - **X**
Olive Ridley Sea Turtle (T/E) - **X**
Leatherback Sea Turtle (E) - **X**
North Pacific Loggerhead Sea Turtle (E) - **X**

ESA Whales

Blue Whale (E) - **X**
Fin Whale (E) - **X**
Humpback Whale (E) - **X**
Southern Resident Killer Whale (E) - **X**
North Pacific Right Whale (E) - **X**
Sei Whale (E) - **X**
Sperm Whale (E) - **X**

ESA Pinnipeds

Guadalupe Fur Seal (T) - **X**

Essential Fish Habitat

Coho EFH - **X**
Chinook Salmon EFH -
Groundfish EFH - **X**
Coastal Pelagics EFH - **X**

Highly Migratory Species EFH - **X**

MMPA Species (See list at left)

ESA and MMPA Cetaceans/Pinnipeds

See list at left and consult Monica DeAngelis

monica.deangelis@noaa.gov

562-980-3232

MMPA Cetaceans - **X**

MMPA Pinnipeds - **X**

Quad Name **Pigeon Point**

Quad Number **37122-B4**

ESA Anadromous Fish

SONCC Coho ESU (T) -

CCC Coho ESU (E) - **X**

CC Chinook Salmon ESU (T) -

CVSR Chinook Salmon ESU (T) -

SRWR Chinook Salmon ESU (E) -

NC Steelhead DPS (T) -

CCC Steelhead DPS (T) - **X**

SCCC Steelhead DPS (T) -

SC Steelhead DPS (E) -

CCV Steelhead DPS (T) -

Eulachon (T) -

sDPS Green Sturgeon (T) - **X**

ESA Anadromous Fish Critical Habitat

SONCC Coho Critical Habitat -

CCC Coho Critical Habitat - **X**

CC Chinook Salmon Critical Habitat -

CVSR Chinook Salmon Critical Habitat -

SRWR Chinook Salmon Critical Habitat -

NC Steelhead Critical Habitat -

CCC Steelhead Critical Habitat - X
SCCC Steelhead Critical Habitat -
SC Steelhead Critical Habitat -
CCV Steelhead Critical Habitat -
Eulachon Critical Habitat -
sDPS Green Sturgeon Critical Habitat - X

ESA Marine Invertebrates

Range Black Abalone (E) - X
Range White Abalone (E) -

ESA Marine Invertebrates Critical Habitat

Black Abalone Critical Habitat - X

ESA Sea Turtles

East Pacific Green Sea Turtle (T) - X
Olive Ridley Sea Turtle (T/E) - X
Leatherback Sea Turtle (E) - X
North Pacific Loggerhead Sea Turtle (E) - X

ESA Whales

Blue Whale (E) - X
Fin Whale (E) - X
Humpback Whale (E) - X
Southern Resident Killer Whale (E) - X
North Pacific Right Whale (E) - X
Sei Whale (E) - X
Sperm Whale (E) - X

ESA Pinnipeds

Guadalupe Fur Seal (T) - X

Essential Fish Habitat

Coho EFH - X
Chinook Salmon EFH -
Groundfish EFH - X
Coastal Pelagics EFH - X
Highly Migratory Species EFH - X

MMPA Species (See list at left)

ESA and MMPA Cetaceans/Pinnipeds

**See list at left and consult Monica DeAngelis
monica.deangelis@noaa.gov
562-980-3232**

MMPA Cetaceans - X
MMPA Pinnipeds - X

Quad Name **Franklin Point**

Quad Number **37122-B3**

ESA Anadromous Fish

SONCC Coho ESU (T) -
CCC Coho ESU (E) - X
CC Chinook Salmon ESU (T) -
CVSR Chinook Salmon ESU (T) -
SRWR Chinook Salmon ESU (E) -
NC Steelhead DPS (T) -
CCC Steelhead DPS (T) - X
SCCC Steelhead DPS (T) -
SC Steelhead DPS (E) -
CCV Steelhead DPS (T) -

Eulachon (T) -

sDPS Green Sturgeon (T) - **X**

ESA Anadromous Fish Critical Habitat

SONCC Coho Critical Habitat -

CCC Coho Critical Habitat - **X**

CC Chinook Salmon Critical Habitat -

CVSR Chinook Salmon Critical Habitat -

SRWR Chinook Salmon Critical Habitat -

NC Steelhead Critical Habitat -

CCC Steelhead Critical Habitat - **X**

SCCC Steelhead Critical Habitat -

SC Steelhead Critical Habitat -

CCV Steelhead Critical Habitat -

Eulachon Critical Habitat -

sDPS Green Sturgeon Critical Habitat - **X**

ESA Marine Invertebrates

Range Black Abalone (E) - **X**

Range White Abalone (E) -

ESA Marine Invertebrates Critical Habitat

Black Abalone Critical Habitat - **X**

ESA Sea Turtles

East Pacific Green Sea Turtle (T) - **X**

Olive Ridley Sea Turtle (T/E) - X

Leatherback Sea Turtle (E) - X

North Pacific Loggerhead Sea Turtle (E) - X

ESA Whales

Blue Whale (E) - X

Fin Whale (E) - X

Humpback Whale (E) - X

Southern Resident Killer Whale (E) - X

North Pacific Right Whale (E) - X

Sei Whale (E) - X

Sperm Whale (E) - X

ESA Pinnipeds

Guadalupe Fur Seal (T) - X

Essential Fish Habitat

Coho EFH - X

Chinook Salmon EFH -

Groundfish EFH - X

Coastal Pelagics EFH - X

Highly Migratory Species EFH - X

MMPA Species (See list at left)

ESA and MMPA Cetaceans/Pinnipeds
See list at left and consult Monica DeAngelis
monica.deangelis@noaa.gov
562-980-3232

MMPA Cetaceans - **X**

MMPA Pinnipeds - **X**

Quad Name **Big Basin**

Quad Number **37122-B2**

ESA Anadromous Fish

SONCC Coho ESU (T) -

CCC Coho ESU (E) - **X**

CC Chinook Salmon ESU (T) -

CVSR Chinook Salmon ESU (T) -

SRWR Chinook Salmon ESU (E) -

NC Steelhead DPS (T) -

CCC Steelhead DPS (T) - **X**

SCCC Steelhead DPS (T) -

SC Steelhead DPS (E) -

CCV Steelhead DPS (T) -

Eulachon (T) -

sDPS Green Sturgeon (T) -

ESA Anadromous Fish Critical Habitat

SONCC Coho Critical Habitat -

CCC Coho Critical Habitat -

X

CC Chinook Salmon Critical Habitat -

CVSR Chinook Salmon Critical Habitat -

SRWR Chinook Salmon Critical Habitat -

NC Steelhead Critical Habitat -

CCC Steelhead Critical Habitat -

X

SCCC Steelhead Critical Habitat -

SC Steelhead Critical Habitat -

CCV Steelhead Critical Habitat -

Eulachon Critical Habitat -

sDPS Green Sturgeon Critical Habitat -

ESA Marine Invertebrates

Range Black Abalone (E) -

Range White Abalone (E) -

ESA Marine Invertebrates Critical Habitat

Black Abalone Critical Habitat -

ESA Sea Turtles

East Pacific Green Sea Turtle (T) -

Olive Ridley Sea Turtle (T/E) -

Leatherback Sea Turtle (E) -

North Pacific Loggerhead Sea Turtle (E) -

ESA Whales

Blue Whale (E) -

Fin Whale (E) -

Humpback Whale (E) -

Southern Resident Killer Whale (E) -

North Pacific Right Whale (E) -

Sei Whale (E) -

Sperm Whale (E) -

ESA Pinnipeds

Guadalupe Fur Seal (T) -

Essential Fish Habitat

Coho EFH -

X

Chinook Salmon EFH -

Groundfish EFH -

Coastal Pelagics EFH -

Highly Migratory Species EFH -

MMPA Species (See list at left)

ESA and MMPA Cetaceans/Pinnipeds

See list at left and consult Monica DeAngelis

monica.deangelis@noaa.gov

562-980-3232

MMPA Cetaceans -

MMPA Pinnipeds -

Quad Name **Davenport**

Quad Number **37122-A2**

ESA Anadromous Fish

SONCC Coho ESU (T) -

CCC Coho ESU (E) -

X

CC Chinook Salmon ESU (T) -

CVSR Chinook Salmon ESU (T) -

SRWR Chinook Salmon ESU (E) -

NC Steelhead DPS (T) -

CCC Steelhead DPS (T) -

X

SCCC Steelhead DPS (T) -

SC Steelhead DPS (E) -

CCV Steelhead DPS (T) -

Eulachon (T) -

sDPS Green Sturgeon (T) -

X

ESA Anadromous Fish Critical Habitat

SONCC Coho Critical Habitat -

CCC Coho Critical Habitat -

X

CC Chinook Salmon Critical Habitat -

CVSR Chinook Salmon Critical Habitat -

SRWR Chinook Salmon Critical Habitat -

NC Steelhead Critical Habitat -

CCC Steelhead Critical Habitat -

X

SCCC Steelhead Critical Habitat -

SC Steelhead Critical Habitat -

CCV Steelhead Critical Habitat -

Eulachon Critical Habitat -

sDPS Green Sturgeon Critical Habitat - **X**

ESA Marine Invertebrates

Range Black Abalone (E) - **X**

Range White Abalone (E) -

ESA Marine Invertebrates Critical Habitat

Black Abalone Critical Habitat - **X**

ESA Sea Turtles

East Pacific Green Sea Turtle (T) - **X**

Olive Ridley Sea Turtle (T/E) - **X**

Leatherback Sea Turtle (E) - **X**

North Pacific Loggerhead Sea Turtle (E) - **X**

ESA Whales

Blue Whale (E) - **X**

Fin Whale (E) - **X**

Humpback Whale (E) - **X**

Southern Resident Killer Whale (E) - **X**

North Pacific Right Whale (E) - **X**

Sei Whale (E) - **X**

Sperm Whale (E) - X

ESA Pinnipeds

Guadalupe Fur Seal (T) - X

Essential Fish Habitat

Coho EFH - X

Chinook Salmon EFH -

Groundfish EFH - X

Coastal Pelagics EFH - X

Highly Migratory Species EFH - X

MMPA Species (See list at left)

ESA and MMPA Cetaceans/Pinnipeds

See list at left and consult Monica DeAngelis

monica.deangelis@noaa.gov

562-980-3232

MMPA Cetaceans - X

MMPA Pinnipeds - X

Quad Name **Santa Cruz OE W**

Quad Number **36122-H2**

ESA Anadromous Fish

SONCC Coho ESU (T) -

CCC Coho ESU (E) - X

CC Chinook Salmon ESU (T) -

CVSR Chinook Salmon ESU (T) -

SRWR Chinook Salmon ESU (E) -

NC Steelhead DPS (T) -

CCC Steelhead DPS (T) - **X**

SCCC Steelhead DPS (T) -

SC Steelhead DPS (E) -

CCV Steelhead DPS (T) -

Eulachon (T) -

sDPS Green Sturgeon (T) - **X**

ESA Anadromous Fish Critical Habitat

SONCC Coho Critical Habitat -

CCC Coho Critical Habitat - **X**

CC Chinook Salmon Critical Habitat -

CVSR Chinook Salmon Critical Habitat -

SRWR Chinook Salmon Critical Habitat -

NC Steelhead Critical Habitat -

CCC Steelhead Critical Habitat - **X**

SCCC Steelhead Critical Habitat -

SC Steelhead Critical Habitat -

CCV Steelhead Critical Habitat -

Eulachon Critical Habitat -

sDPS Green Sturgeon Critical Habitat - **X**

ESA Marine Invertebrates

Range Black Abalone (E) - **X**

Range White Abalone (E) -

ESA Marine Invertebrates Critical Habitat

Black Abalone Critical Habitat - **X**

ESA Sea Turtles

East Pacific Green Sea Turtle (T) - **X**

Olive Ridley Sea Turtle (T/E) - **X**

Leatherback Sea Turtle (E) - **X**

North Pacific Loggerhead Sea Turtle (E) - **X**

ESA Whales

Blue Whale (E) - **X**

Fin Whale (E) - **X**

Humpback Whale (E) - **X**

Southern Resident Killer Whale (E) - **X**

North Pacific Right Whale (E) - **X**

Sei Whale (E) - **X**

Sperm Whale (E) - **X**

ESA Pinnipeds

Guadalupe Fur Seal (T) - **X**

Essential Fish Habitat

Coho EFH - **X**

Chinook Salmon EFH -

Groundfish EFH - **X**

Coastal Pelagics EFH - **X**

Highly Migratory Species EFH - **X**

MMPA Species (See list at left)

ESA and MMPA Cetaceans/Pinnipeds

See list at left and consult Monica DeAngelis

monica.deangelis@noaa.gov

562-980-3232

MMPA Cetaceans - **X**

MMPA Pinnipeds - **X**

MMPA Species

Click on blue text "MMPA Species" above

Consult Monica DeAngelis

monica.deangelis@noaa.gov

562-980-3232

Species	MMPA Status	ESA Status
Baird's Beaked Whale	<i>MMPA Depleted</i>	
Blue Whale	<i>MMPA Depleted</i>	<i>E</i>
Cuvier's Beaked Whale	MMPA Protection	
Dwarf Sperm Whale	MMPA Protection	
False Killer Whale	MMPA Protection	
Fin Whale	<i>MMPA Depleted</i>	<i>E</i>

Gray Whale (Western North Pacific)	<i>MMPA Depleted</i>	<i>E</i>
Gray Whale (Eastern North Pacific)	MMPA Protection	
Hubb's Beaked Whale	MMPA Protection	
Humpback Whale	<i>MMPA Depleted</i>	<i>E</i>
Killer Whale (Southern Resident)	<i>MMPA Depleted</i>	<i>E</i>
Killer Whale	<i>MMPA Depleted</i>	
Minke Whale	MMPA Protection	
North Pacific Right Whale	<i>MMPA Depleted</i>	<i>E</i>
Pygmy Sperm Whale	MMPA Protection	
Sei Whale	<i>MMPA Depleted</i>	<i>E</i>
Short Finned Pilot Whale	MMPA Protection	
Sperm Whale	<i>MMPA Depleted</i>	<i>E</i>
Stejneger's Beaked Whale	MMPA Protection	
Dall's Porpoise	MMPA Protection	
Harbor Porpoise	MMPA Protection	
Northern Right Whale Dolphin	MMPA Protection	
Pacific White Sided Dolphin	MMPA Protection	
Risso's Dolphin	MMPA Protection	
Short Beaked Common Dolphin	MMPA Protection	
Striped Dolphin	MMPA Protection	
California Sea Lion	MMPA Protection	
Guadalupe Fur Seal	<i>MMPA Depleted</i>	<i>T</i>
Northern Elephant Seal	MMPA Protection	

Northern Fur Seal

MMPA Depleted

Pacific Harbor Seal

MMPA Protection

Steller Sea Lion

MMPA Protection

Appendix D Wetland Delineation and Rare Plant Survey Memo

M e m o r a n d u m

*Making Conservation
a California Way of Life*

To: RACHEL COTRONEO
CH2M HILL

Date: June 20, 2017

File: SM-04-0J210
0413000444
*Elliot Creek Storm
Damage*

From: ELIZABETH LEYVAS
Environmental Planner (Natural Sciences)
Office of Biological Sciences and Permits
D4 Oakland Office

Subject: WETLAND DELINEATION AND RARE PLANT MEMO

Project Description:

The California Department of Transportation (Caltrans) proposes to stabilize a slope with rock slope protection (RSP), add two new drainage inlets and dikes, and correct a sag point in the road. This will occur on State Route 1 (SR 1) at Post Mile 0.3 over Elliot Creek in San Mateo County. The purpose of the project is to correct existing storm damage and to prevent future erosion. This project is needed to enhance driver safety and to prevent future erosion. Major project components include: 1) placing 1500 square feet (0.048 acres) of rock slope protection (RSP) on the bluff west of the project site; 2) installing two drainage inlets and dikes along the southbound direction; 3) correcting a sag point in the road by digging down to a maximum of five feet across both lanes of traffic; 4) repairing/resurfacing the existing roadway as needed; 5) place soil over RSP two feet high (3,000 cubic feet); and 6) revegetate disturbed soil.

Rock slope protection will be installed to repair erosion adjacent to the roadway and will permanently impact 0.048 acres on the southbound side of SR 1. Staging encompasses approximately 0.09 acres of soil and will be located about 250 feet south of this area on the southbound side of SR 1. All work will be conducted during the day, over a period of 40 working days (eight weeks). A one-lane road closure will be used to accommodate traffic flow during construction.

Biological Setting:

The project area lies on a bluff within the fog belt of the California coast, and is subject to storm water runoff from SR 1. It is about 20 feet above a culverted creek (Elliot Creek) and is not near

the water table. The nearest wetland aside from this culverted creek is 0.5 miles north. This area is characterized as coastal bluff scrub and Monterey pine forest. Primary land use is for California state parks and agriculture.

Rare Plant and Wetland Delineation:

A field visit was conducted on April 27th 2017, at which time conditions were clear and temperatures were in the mid 60's. Caltrans biologists Elizabeth Leyvas and Mita Nagarkar surveyed areas within the project footprint including the staging area, the shoulders of the road, and the slope (approximately 0.25 acres total). The primary purpose of the survey was to assess the potential for rare plants to occur in the project area, and to determine presence of jurisdictional wetlands. Vegetation was characterized by coastal bluff scrub, non-native ice plants, Monterey pine, and dense growth of poison oak and non-native grasses. No rare plants were seen during the site visit. The California Department of Fish and Wildlife (CDFW) database searches in the California Natural Diversity Database (CNDDDB), as well as records from the Calflora database are consistent with our survey. Rare plants are unlikely to appear onsite.

It was determined that no hydrophytic vegetation, hydric soils, or wetland hydrology was present within the project footprint and that Elliot Creek was the only jurisdictional water within the biological study area (BSA). Soil pits were not dug, due to the lack of hydrophytic vegetation. The USDA Web Soil Survey shows no hydric rating for soils present in this location. The vegetation onsite was consistent with coastal bluff scrub, and the dominant tree type was Monterey pine. The California Coastal Commission [California Code of Regulations Title 14 (14 CCR)] only requires a one parameter standard for wetlands. Based on our site visit, we assume no U.S. Army Corps of Engineers (ACOE) or CCC jurisdictional wetlands are present within the BSA. However, Elliot Creek within the BSA is jurisdictional to both agencies. This jurisdictional section of Elliot Creek is culverted and will be avoided; all work will be done above the bank of Elliot Creek.

Conclusions:

A wetland delineation was not performed due to the lack of evidence of qualifying characteristics. The project site is approximately 0.25 acres that encompasses staging, RSP, and areas along the shoulder, is not a wetland. Rare plants are unlikely to appear onsite.

References:

California Natural Diversity Database (CNDDDB) Rare Find 5. 2017. California Department of Fish and Wildlife. 2016-2017. Available:

<https://www.wildlife.ca.gov/Data/CNDDDB/Maps-and-Data>.

Calflora: Information on California plants for education, research and conservation. [web application]. 2017. Berkeley, California: The Calflora Database [a non-profit organization]. Available: <http://www.calflora.org/> (Accessed: April 26, 2017).

Plant List

Family	Scientific Name	Common Name	Status
Aizoaceae	<i>Carpobrotus edulis</i>	iceplant	invasive
Anacardiaceae	<i>Toxicodendron diversilobum</i>	poison oak	native
Apiaceae	<i>Conium maculatum</i>	poison hemlock	invasive
Asteraceae	<i>Artemisia californica</i>	California sagebrush	native
Asteraceae	<i>Baccharis pilularis</i>	coyote brush,	native
Asteraceae	<i>Carduus pycnocephalus</i>	Italian thistle	invasive
Asteraceae	<i>Cirsium vulgare</i>	bull thistle	invasive
Asteraceae	<i>Helminthotheca echioides</i>	bristly ox-tongue	invasive
Asteraceae	<i>Matricaria discoidea</i>	pineapple weed	native
Brassicaceae	<i>Raphanus sativus</i>	wild radish	invasive
Crassulaceae	<i>Dudeya farinose</i>	sea lettuce	native
Cucurbitaceae	<i>Marah fabacea</i>	California man-root	native
Cupressaceae	<i>Cupressus macrocarpa</i>	Monterey cypress	non-native
Fabaceae	<i>Vicia sativa ssp. sativa</i>	garden vetch	non-native
Fagaceae	<i>Notholithocarpus densiflorus</i>	tanoak	native
Geraniaceae	<i>Geranium dissectum</i>	cut leaved geranium	invasive
Geraniaceae	<i>Geranium molle</i>	crane's bill geranium	non-native
Lysimachia	<i>Lysimachia arvensis</i>	scarlet pimpernel	non-native
Oxalidaceae	<i>Oxalis pes-caprae</i>	Bermuda buttercup	invasive
Papaveraceae	<i>Eschscholzia californica</i>	California poppy	native
Pinus	<i>Pinus attenuata</i>	knobcone pine	native
Pinus	<i>Pinus radiata</i>	Monterey pine	invasive/1B.1
Plantaginaceae	<i>Plantago lanceolate</i>	English plantain	invasive
Poaceae	<i>Avena fatua</i>	wild oat	invasive

Poaceae	<i>Briza maxima</i>	rattlesnake grass	invasive
Poaceae	<i>Bromus diandrus</i>	ripgut brome	invasive
Poaceae	<i>Holcus lanatus</i>	velvet grass	invasive
Polygonaceae	<i>Rumex sp.</i>	dock	
Rosaceae	<i>Heteromeles arbutifolia</i>	Christmas berry/ Toyon	native
Rosaceae	<i>Rubus ursinus</i>	California blackberry	native



County of San Mateo - Planning and Building Department

ATTACHMENT F

NEPA/CEQA RE-VALIDATION FORM

DIST./CO./RTE.	4/SM/1
PM/PM	0.3, 0.6
E.A. or Fed-Aid Project No.	0J210
Other Project No. (specify)	0413000444
PROJECT TITLE	Elliot Creek Slope Repair (and Finney Creek)
ENVIRONMENTAL APPROVAL TYPE	CE/CE
DATE APPROVED	October 2017
REASON FOR CONSULTATION (23 CFR 771.129)	<i>Check reason for consultation:</i> <input type="checkbox"/> Project proceeding to next major federal approval <input checked="" type="checkbox"/> Change in scope, setting, effects, mitigation measures, requirements <input type="checkbox"/> 3-year timeline (EIS only) <input type="checkbox"/> N/A (Re-Validation for CEQA only)
DESCRIPTION OF CHANGED CONDITIONS	Additional location Finney Creek added to project scope.

NEPA CONCLUSION - VALIDITY

Based on an examination of the changed conditions and supporting information: [Check ONE of the three statements below, regarding the validity of the original document/determination (23 CFR 771.129). If document is no longer valid, indicate whether additional public review is warranted and whether the type of environmental document will be elevated.]

- The original environmental document or CE remains valid. No further documentation will be prepared.
- The original environmental document or CE is in need of updating; further documentation has been prepared and is included on the continuation sheet(s) or is attached. With this additional documentation, the original ED or CE remains valid.
 Additional public review is warranted (23 CFR 771.111(h)(3)) Yes No
- The original document or CE is no longer valid.
 Additional public review is warranted (23 CFR 771.111(h)(3)) Yes No
 Supplemental environmental document is needed. Yes No
 New environmental document is needed. Yes No (If "Yes," specify type: _____)

CONCURRENCE WITH NEPA CONCLUSION

I concur with the NEPA conclusion above.

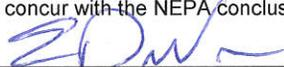

Signature: Environmental Branch Chief Date: 2/20/18 Signature: Project Manager/DLAE Date: 2/20/18

CEQA CONCLUSION: (Only mandated for projects on the State Highway System.)

Based on an examination of the changed conditions and supporting information, the following conclusion has been reached regarding appropriate CEQA documentation: (Check ONE of the five statements below, indicating whether any additional documentation will be prepared, and if so, what kind. If additional documentation is prepared, attach a copy of this signed form and any continuation sheets.)

- Original document remains valid. No further documentation is necessary.
- Only minor technical changes or additions to the previous document are necessary. An addendum has been or will be prepared and is included on the continuation sheets or will be attached. It need not be circulated for public review. (CEQA Guidelines, §15164)
- Changes are substantial, but only minor additions or changes are necessary to make the previous document adequate. A Supplemental environmental document will be prepared, and it will be circulated for public review. (CEQA Guidelines, §15163)
- Changes are substantial, and major revisions to the current document are necessary. A Subsequent environmental document will be prepared, and it will be circulated for public review. (CEQA Guidelines, §15162) (Specify type of subsequent document, e.g., Subsequent FEIR)
- The CE is no longer valid. New CE is needed. Yes No

CONCURRENCE WITH CEQA CONCLUSION

I concur with the CEQA conclusion above.

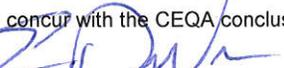

Signature: Environmental Branch Chief Date: 2/20/18 Signature: Project Manager/DLAE Date: 2/20/18

NEPA/CEQA RE-VALIDATION FORM

CONTINUATION SHEET(S)

Address only changes or new information since approval of the original document and only those areas that are applicable. Use the list below as section headings as they apply to the project change(s). Use as much or as little space as needed to adequately address the project change(s) and the associated impacts, minimization, avoidance and/or mitigation measures, if any.

Changes in project design, e.g., scope change; a new alternative; change in project alignment

Deficient drainage has created excessive ponding and slope erosion on the eastside of State Route 1 at PM 0.6, at Finney Creek. Due to the proximity of Finney Creek to Elliot Creek, this location was added to the project following the PDT meeting held on November 21, 2017. DAF Report No. CYC-CT4-1-225-0 dated May 30, 2012 initiated a storm damage project at Finney Creek, located 0.3 miles north of Elliot Creek. The proposed repairs include upgrading the drainage system with the following:

1. Capping the entrance of the existing down drain
2. Installation of three 18-inch diameter drain inlets connecting the inlets in the northbound direction
3. Re-construction of a concrete-lined dike
4. Installation of a down drain and rock pad at the discharge point into Finny Creek.

Changes in environmental setting, e.g., new development affecting traffic or air quality;

There are no changes to the environmental setting since the original document approval.

Changes in environmental circumstances, e.g., a new law or regulation; change in the status of a listed species.

There have been no changes in environmental circumstances since project approval.

Changes to environmental impacts of the project, e.g., a new type of impact, or a change in the magnitude of an existing impact.

Cultural Resources: No impacts are expected to occur to archeological or historical resources within the project area.

Staging Area: An approximately 60 feet by 20 feet (0.03 acre) ruderal roadside area approximately 30 feet north of the work area will be used for staging and equipment storage.

Vegetation Removal: The project proposes to clear an area measuring 30 feet by 50 feet located on the bluff on the west side of SR 1. The vegetation will be removed using hand tools followed by heavy equipment. Trees smaller than 12 inches in diameter at breast height (dbh) will be removed. Native vegetation that is removed will be reused at the end of the project within the work area.

Visual Resources: No new impacts will occur by additional project scope. Same avoidance measures as originally disclosed will apply to the new project location.

Biological Resources: The Project would potentially result in impacts to the following resources: Federally threatened California red-legged frog (*Rana draytonii*) (CRLF) and its associated habitat and critical habitat Federally endangered San Francisco Garter Snake (*Thamnophis sirtalis tetrataenia*) (SFGS) and its associated habitat Federally threatened marbled murrelet (*Brachyramphus marmoratus*) (MAMU) and its associated habitat California

NEPA/CEQA RE-VALIDATION FORM

species of special concern San Francisco Dusky-Footed Woodrat (*Neotoma fuscipes annectens*) and its associated habitat (SF DFWR). The new scope will add an additional 0.6 acre to be temporarily disturbed for a total of 0.078 acre. 0.01 acre of permanent impacts will be added with the additional project scope for a total of 0.035 acre.

Changes to avoidance, minimization, and/or mitigation measures since the environmental document was approved.

VISUAL

1. Any new concrete structures that are visible along the slopes shall be stained to blend with coastal landscape.
2. Any exposed metal piping will be stained with Natina Steel to blend into the natural surroundings.

WATER QUALITY

1. Temporary Construction Site Best Management Practices (BMPs), such as silt fence, fiber roll, check dam, drainage inlet protection, concrete wash-out, street sweeping, and construction entrance will be deployed for sediment control and material management. These BMPs are representative of those which may be recommended during the subsequent PS&E phase.
2. Groundwater characterization should take place during the design phase.
3. A WPCP will be required.

COASTAL PERMIT

The project is inside of the California Coastal Zone and therefore it is under the jurisdiction of the California Coastal Commission (CCC). An application was submitted to San Mateo County, who was designated coastal jurisdiction of this area by CCC on February 13, 2018.

BIOLOGY

An amended biological opinion from the United States Fish and Wildlife was provided in January 2018 with the following conditions:

1. An USFWS approved biological monitor will be onsite during all work that could reasonably result in take of the CRLF or SFGS. The monitor will have authority to stop work if activities result in take of these special status species. Resident engineer will be immediately informed.
2. The Contractor shall comply with the conservation measures 1-25 outlined in the biological opinion from USFWS. Measures are discussed in further detail in the attached environmental commitment record.

Changes to environmental commitments since the environmental document was approved, e.g., the addition of new conditions in permits or approvals. When this applies, append a revised Environmental Commitments Record (ECR) as one of the Continuation Sheets.

Please see attached ECR for updated commitments.



County of San Mateo - Planning and Building Department

ATTACHMENT G



United States Department of the Interior



In Reply Refer to:
08ESMF00-
2017-F-3006-
R001-1

FISH AND WILDLIFE SERVICE
Sacramento Fish and Wildlife Office
2800 Cottage Way, Suite W-2605
Sacramento, California 95825-1846

JAN 19 2018

Ms. JoAnn Cullom
California Department of Transportation
Environmental Division, MS-8E
111 Grand Avenue
Oakland, California 94612

Subject: Reinitiation of Formal Consultation on the State Route 1 Elliot Creek and
Finney Creek Storm Damage Project, San Mateo County, California (Caltrans
EA 0J210)

Dear Ms. Cullom:

This letter is in response to the California Department of Transportation's (Caltrans) December 19, 2017, request to reinitiate formal consultation with the U.S. Fish and Wildlife Service (Service) on the proposed State Route (SR) 1 Elliot Creek Storm Damage Project in San Mateo County, California. Your request was received by the Service on December 19, 2017. Our original biological opinion on the effects of the project was issued on September 20, 2017 (Service File #08ESMF00-2017-F-3006-1). The requested reinitiation was triggered by the addition of proposed work activities at the intersection of SR 1 and Finney Creek and therefore changing the name of the project to the SR 1 Elliot Creek and Finney Creek Storm Damage Project. In response, we are issuing this amended biological opinion to address the additional proposed activities and expanded action area.

At issue are the proposed project's effects on the federally threatened California red-legged frog (*Rana draytonii*) and its critical habitat, and the federally endangered San Francisco garter snake (*Thamnophis sirtalis tetrataenia*). Critical habitat has not been designated for the San Francisco garter snake. This response is provided under the authority of the Endangered Species Act of 1973, as amended (16 U.S.C. § 1531 et seq.)(Act), and in accordance with the implementing regulations pertaining to interagency cooperation (50 CFR 402).

Fixing America's Surface Transportation Act (FAST Act) was signed into law on December 4, 2015. Providing funding from 2016 to 2020, the FAST Act includes provisions to promote streamlined and accelerated project delivery. Caltrans is approved to participate in the FAST Act project delivery program through the National Environmental Policy Act (NEPA) Assignment Memorandum of Understanding (MOU). The MOU allows Caltrans to assume the Federal Highway Administration's (FHWA) responsibilities under NEPA as well as FHWA's consultation and coordination responsibilities under federal environmental laws for most highway projects in California. Caltrans is exercising this authority as the nexus for section 7 consultation under the Act on this project.

The federal action we are consulting on includes repair of a section of eroding coastal bluff and roadway settlement near Post Mile (PM) 0.3 at the crossing of Elliot Creek and erosion and roadway settlement near PM 0.6 at the crossing of Finney Creek in order to maintain the integrity of the SR 1 roadway and minimize effects to the surrounding landscape. We reviewed your August 2017

Biological Assessment (BA) in preparation of the September 20, 2017 biological opinion and provided additional information for this reinitiation regarding the proposed activities associated with Finney Creek for our review and requested concurrence with the findings presented therein. These findings conclude that, similar to the proposed Elliot Creek work, the proposed actions at Finney Creek may affect and are likely to adversely affect the California red-legged frog and the San Francisco garter snake, and that the associated actions would not result in an adverse modification of California red-legged frog critical habitat.

In considering your request, we based our evaluation on the following: (1) the September 20, 2017 biological opinion; (2) a revised project description received on December 28, 2017; (3) the December 19, 2017, request for reinitiation; and (4) other information available to the Service.

The remainder of this document provides our revised biological opinion on the effects of the proposed project on the California red-legged frog, its critical habitat, and the San Francisco garter snake.

Consultation History

January 23, 2017	The Service received Caltrans' initial project introduction and request for technical assistance.
April 27, 2017	The Service visited the proposed project site with Caltrans to gather project information and offer technical assistance.
May 4, 2017	The Service sent Caltrans an e-mail message with technical assistance related to the recent site visit.
July 19, 2017	The Service and Caltrans exchanged e-mail messages concerning the placement of cover over the proposed RSP.
August 17, 2017	The Service received a copy of Caltrans' August 17, 2017 request for consultation along with an August 2017 BA.
August 21, 2017	The Service sent Caltrans an e-mail message concerning our review of the August 2017 BA. The message included a request for additional information and clarification. The message was the equivalent of a 30-day letter.
August 21, 2017	The Service received an e-mail message from Caltrans in response to our August 21, 2017 request for additional information. The provided information completed the consultation package
September 20, 2017	The Service issued a biological opinion for the originally proposed project (Service File #08ESMF00-2017-F-3006-1).
December 6, 2017	The Service received an e-mail message from Caltrans which included a draft revised project description which included revisions to the proposed Elliot Creek location work and the addition of the proposed Finney Creek location work.

- December 19, 2017 The Service received Caltrans' December 19, 2017, request to reinstate consultation.
- December 22, 2017 The Service received revised project information from Caltrans via an e-mail attachment.
- December 28, 2017 The Service received final revised project information from Caltrans via an e-mail attachment.

BIOLOGICAL OPINION

Description of the Action

The proposed project includes stormwater-related repairs at two locations on SR 1, just south of Ano Nuevo State Park. The two locations are in association with SR 1 creek crossings. The southern work segment is located in the vicinity of PM 0.3, near the culverted crossing of Elliot Creek. The northern work segment is located in the vicinity of PM 0.6, near the culverted crossing of Finney Creek. Sheet flow, surface runoff, and saturated soils have resulted in issues at both locations which compromise the integrity of the roadway and present issues for travel safety.

Throughout this overall area, SR1 is a two-lane highway (one lane in each direction). Access will be gained directly from SR 1. Construction is expected to begin in July 2018. No night work is expected. Temporarily disturbed areas will be restored to pre-construction conditions, and any remaining excavated soil if any will be disposed of at an approved disposal site or upland location. A traffic management plan would be prepared prior to construction. The project activities will be contained within the Caltrans right-of-way (ROW). All construction-related materials will be removed after completion of construction activities.

The proposed activities are described below by location.

Elliot Creek

The proposed activities at the PM 0.3, Elliot Creek location include repair of an eroding embankment, repair of pavement settlement, maintenance of the roadway integrity, and improving driver safety. The issues are and the associated repairs will be primarily on the west side of the roadway and include the following:

1. Excavation of an approximately 0.03 acre slip-out and placement of 1,140 square feet (0.03 acre) of rock slope protection (RSP) on the bluff west of Post Mile 0.3;
2. The placement of at least 1 foot of soil over the RSP (1,140 cubic feet);
3. Installation of two drain inlets and a dike in the southbound direction;
4. Correction of a recurring sag point in the roadway caused by repeated settlement; and
5. Revegetation of disturbed soil using hydro-seed.

A 0.087 acre equipment staging area will be used approximately 240 feet south of the slip-out within a pre-existing, compact soil pullout. Access will be gained directly from SR 1. Staging and access will include temporary k-rail barriers, lane closures, and signage. Construction equipment will likely include the use of a mini excavator, backhoe, front end loader, jack hammer, saw cutter, skid steer

loader, asphalt paver, pavement roller, forklift, water truck, dump truck, truck-mounted drill, Styrofoam injector, and small asphalt pavement grinder. A one-lane road closure will be used to accommodate traffic flow during construction.

Repair of the slip-out will include excavation of the eroded area on the west side of SR 1. The area to be excavated comprises approximately 0.030 acre (30 by 50 feet). An additional 0.014 acre area surrounding the excavation will be used for work space, resulting in an approximately 0.044 acre area of disturbance. Prior to the excavation, the vegetative cover in this area will be removed using hand tools followed by the use of heavy equipment. Trees smaller than 12 inches in diameter at breast height (dbh) will be removed. Some of the removed woody material will be reserved and used to as cover debris that will be replaced over the RSP cap. The excavation will extend at least a foot deep and may extend up to 5 feet depending on conditions observed during the action. This loose material will be replaced with RSP for stability. RSP placement will include construction of a footing trench at the base of the excavated area. RSP fabric will be laid down and then ¼ ton rock will be mechanically put in place to approximately 2 feet below the top of grade. A perforated pipe will be installed at the base of the RSP, within the footing trench, to capture water and direct it through a down drain. The spaces between the rocks will be filled with native soil (from the excavation) and the RSP will be capped off with at least 1 foot of native soil to match the surrounding landscape contour.

The project will also include the construction of features off the southbound shoulder to capture and redirect sheet flow away from the affected area. This will include a 2-foot wide earthen berm and a 60-foot long asphalt concrete dike paralleling the highway. The dike will direct water towards two new drain inlets whose 15-inch by 48-foot-long corrugated steel pipe down drain will extend down the embankment and discharge into Elliot Creek.

Settling of the adjacent road segment due to the intrusion of storm water under the roadway has created a sag in SR 1 that further contributes to drainage issues. Rather than reconstructing the road, Caltrans will repair this approximately 24 by 30 foot area (0.017 acre) by drilling holes in the pavement to fill voids at varying depths with Styrofoam. Depending on the roadway conditions at the time of construction, this section may also be resurfaced.

The soil-covered RSP area and temporary work zones with bare soil will be hydro-seeded using a native plant erosion control mix. Additionally, large woody native vegetation cut and cleared at the start of excavation will be placed on top of the soil to act as natural ground cover.

Finney Creek

Deficient drainage has created issues with excessive ponding and slope erosion on the eastside of the roadway at the PM 0.6, Finney Creek location. The proposed repairs include upgrading the drainage system with the following:

1. Capping the entrance of the existing down drain;
2. Installation of three 18-inch diameter drain inlets connecting the inlets in the northbound direction;
3. Re-construction of a concrete-lined dike; and
4. Installation of a down drain and rock pad at the discharge point into Finney Creek.

An approximately 60 by 20 foot (0.03 acre) ruderal roadside area approximately 30 feet north of the work area will be used for staging and equipment storage.

Vegetation will be cleared from a 16 by 30 foot area located on the eastside of the roadway for a down drain and rock pad installation. The down drain will be installed above the original ground and the 6 by 6 foot rock pad will be placed using mechanical and hand tools. The surrounding ground will be compacted and leveled prior to placement and the equipment used will likely include a mini loader, water truck, and a dump truck. The down drain and rock pad area will be hydroseeded with native seed material following construction.

A 2 by 2 foot area will also be cleared to cap the entrance of an existing failing down drain. The vegetation will be removed using hand tools followed by heavy equipment. Trees with less than 6 inches dbh will be removed and some of the woody material will be reserved and used to as ground cover.

The three new drain inlets will be installed along the eastern road shoulder and will connect with the down drain to direct stormwater to the rock pad and ultimately, Finney Creek. The concrete dike will be re-established.

Conservation Measures

Caltrans proposes to reduce adverse effects to the California red-legged frog and San Francisco garter snake by implementing the following measures:

1. A Service-Approved Biological Monitor. The names and qualifications of proposed biological monitor(s) will be submitted to the Service for approval prior to the start of construction. The Service-Approved Biological Monitors will keep a copy of this amended biological opinion in their possession when onsite. Through communication with the Resident Engineer, the Service-Approved Biological Monitor will be onsite during all work that could reasonably result in take of the California red-legged frog or San Francisco garter snake. The Service-Approved Biological Monitor will have the authority to stop work that may result in the unauthorized take of special-status species. If the Service-Approved Biological Monitor exercises this authority, the Service will be notified by telephone and e-mail message within one (1) working day.
2. Worker Environmental Awareness Training. Construction personnel will attend a mandatory environmental education program delivered by the Service-Approved Biological Monitor prior to taking part in site construction, including vegetation clearing. The program will focus on the conservation measures that are relevant to an employee's personal responsibility and will include an explanation as how to best avoid take of the California red-legged frog and San Francisco garter snake. At a minimum, the training will include a description of species; how they might be encountered within the project area; their status and protection; and the relevant *Conservation Measures* and *Terms and Conditions* of the biological opinion. A fact sheet conveying this information will be prepared and distributed to all construction and project personnel. Distributed materials will include cards with distinctive photographs of California red-legged frog and San Francisco garter snake, as well as compliance reminders and relevant contact information. Documentation of the training, including sign-in sheets, will be kept on file and made available to the Service upon request.
3. Pre-Construction Surveys. Pre-construction surveys for the California red-legged frog and San Francisco garter snake will be conducted by the Service-Approved Biological Monitor no more than 20 calendar days prior to any initial ground disturbance and immediately prior

to ground-disturbing activities (including vegetation removal) within upland habitat identified for the species in the August 2017 BA and the December 19, 2017reinitiation. These efforts will consist of walking surveys of the project limits and, if possible, accessible adjacent areas within at least 50 feet of the project limits. The Service-Approved Biological Monitor will investigate potential cover sites when it is feasible and safe to do so. This includes thorough investigation of mammal burrows, rocky outcrops, appropriately sized soil cracks, tree cavities, and debris. Native vertebrates found in the cover sites within the project limits will be documented and relocated to an adequate cover site in the vicinity. Safety permitting, the Service-Approved Biological Monitor will investigate areas of disturbed soil for signs of California red-legged frogs and San Francisco garter snakes within 30 minutes following initial disturbance of the given area.

4. Discovery of Listed Species. The Service-Approved Biological Monitor will be present during all activities that could reasonably result in take of the California red-legged frog or San Francisco garter snake. If at any point a listed species is discovered during these activities, the Service-Approved Biological Monitor through the Resident Engineer or their designee, will halt all work within 50 feet of the animal until the it has either been captured and moved or has moved sufficiently from harm's way on its own volition.
5. Protocol for Species Observation: The Service-Approved Biological Monitor (s) will have the authority to halt work through coordination with the Resident Engineer in the event that a listed species is observed in the action area. The Resident Engineer will keep construction activities suspended in any construction area where the biologist has determined that a potential take of the species could occur. Work will resume after observed listed individuals leave the site voluntarily, the biologist determines that no wildlife is being harassed or harmed by construction activities, or the wildlife is removed by the biologist to a release site using Service-approved handling techniques.
6. Handling of Listed Species. If a listed species is discovered, the Resident Engineer and Service-Approved Biological Monitor will be immediately informed.
 - a. If a California red-legged frog or San Francisco garter snake is discovered in a construction zone, work will be halted immediately within 50 feet until the animal leaves the site or is captured and relocated by the Service-Approved Biological Monitor.
 - b. The Service will be notified within one (1) working day if a California red-legged frog or San Francisco garter snake is discovered within the construction site.
 - c. The captured California red-legged frog or San Francisco garter snake will be released within appropriate habitat outside of the construction area but nearby the capture location. The release habitat will be determined by the Service-Approved Biological Monitor.
 - d. The Service-Approved Biological Monitor will take precautions to prevent introduction of amphibian diseases in accordance with the *Revised Guidance on Site Assessments and Field Surveys for the California Red-legged Frog* (Service 2005).
7. Injured Animals. Injured California red-legged frogs and San Francisco garter snakes will be cared for by a Service-Approved Biological Monitor(s) or a licensed veterinarian, if necessary. Any deceased California red-legged frogs or San Francisco garter snakes will be

preserved according to standard museum techniques and will be held in a secure location. The Service and the California Department of Fish and Wildlife (CDFW) will be notified within one (1) working day of the discovery of a death or an injury to any listed species resulting from project-related activities or if a listed species is observed at a construction site. Notification will include the date, time, and location of the incident or the finding of a deceased or injured animal, clearly indicated on a U.S. Geological Survey 7.5-minute quadrangle and other maps at a finer scale, as requested by the Service or CDFW, and any other pertinent information.

8. Seasonal Avoidance. Construction actions will be scheduled to minimize effects on listed species and habitats. Except for vegetation clearing necessary to minimize effects on nesting birds, all construction-related activities will be conducted between April 15th and October 31st to avoid the period when the San Francisco garter snake may be overwintering in uplands and California red-legged frog are most active.
9. Incident Weather Restriction. No work will occur during or within 24 hours following a rain event exceeding 0.2-inch as measured by the National Oceanic and Atmospheric Association National Weather Service for the Soquel, CA (SOQC1) base station available at: <http://www.wrh.noaa.gov/mtr/versprod.php?pil=RR5&sid=RSA>. The Service and CDFW approval to continue work during or within 24 hours of a rain event will be considered on a case-by-case basis.
10. Construction Boundary Fencing. Before the start of construction. The project footprint boundary will be clearly delineated using high-visibility orange fencing as necessary. Construction work areas will include the active construction site and all areas providing support for the project, including areas used for vehicle parking, equipment and material storage and staging, and access roads. The fencing will remain in place throughout the duration of construction activities, and will be inspected regularly and fully maintained at all times. The final project plans will show all locations where boundary fencing will be installed and will provide installation specifications. The bid solicitation package special provisions will clearly describe acceptable fencing material and prohibited construction-related activities, including vehicle operation, material and equipment storage, access roads and other surface-disturbing activities.
11. Wildlife Exclusion Fencing. Silt fencing or other wildlife exclusion fencing will be installed in conjunction with the construction boundary fencing around the perimeter of the project footprint to allow California red-legged frogs and San Francisco garter snakes to leave but not re-enter the work area. This fence will be installed prior to any work within the project footprint. Exclusion fencing will be at least 3 feet high with the lower 6 inches of the fence buried in the ground. The fence will be pulled taut at each support to prevent folds or snags. Fencing will be installed and maintained in good working condition until completion of the project. The integrity of the fence will be inspected daily, as will the inside and outside boundaries for the California red-legged frog and San Francisco garter snake.
12. Vegetation Removal. Vegetation removal will be limited to the designated work areas needed for access and workspace. Where possible, vegetation removal in temporary work areas will be cut above soil level to promote revegetative growth of established plants following construction.
13. Staging. Construction access, staging, storage, and parking areas will be located within Caltrans ROW on compacted soil and paved surfaces.

14. Night Lighting. No construction is expected to occur at night, however, if any lighting is needed to direct traffic, all lighting will be directed downwards, towards the travel way from sensitive resources or habitats.
15. Vehicle and Equipment Checks. Before moving construction equipment or vehicles into the project site, operators will check underneath those that have been parked onsite for more than 30 minutes and will notify the Service-Approved Biological Monitor if any reptile or amphibian is observed.
16. Proper Use of Erosion Control Devices. To avoid California red-legged frogs and San Francisco garter snakes from becoming entangled, trapped or injured, erosion control materials that use plastic or synthetic mono-filament netting will not be used within the action area.
17. Avoidance of Entrapment. To prevent inadvertent entrapment of animals during construction, all excavated, steep-walled holes or trenches more than 1 foot deep will be covered at the close of each working day by plywood or similar materials. Before such holes or trenches are filled they must be thoroughly inspected for trapped animals. All replacement pipes, culverts, or similar structures stored in the project area overnight will be inspected before they are subsequently moved, capped and/or buried.
18. Migratory Bird Treaty Act. To minimize and avoid take of migratory birds, their nests, and their young, Caltrans will conduct vegetation and tree trimming between September 30 and January 30 before project construction. This work will be limited to vegetation and trees that are within the project footprint. No grubbing or other ground disturbing actions will occur at this time. Upon completion of vegetation and tree trimming, Caltrans will install storm water and erosion control best management practices (BMPs). A Service-Approved Biological Monitor with appropriate construction and species experience will conduct nest and bird surveys and other wildlife surveys before and during tree cutting. All work will be conducted under a Regional Water Board approved Water Pollution Control Plan or Storm Water Pollution Protection Plan. Vegetation will be cleared only where necessary and will be cut above soil level. This will allow plants that reproduce vegetatively to resprout after construction.

During the nesting season, pre-construction surveys for nesting birds will be conducted by a qualified biologist no more than 72 hours prior to the start of construction activities. If work is to occur within 300 feet of active raptor nests or 50 feet of active passerine nests, a non-disturbance buffer will be established at a distance sufficient to minimize disturbance based on the nest location, topography, cover, the species' sensitivity to disturbance, and the intensity/type of potential disturbance. All clearing and grubbing of woody vegetation will be performed by hand or using light construction equipment, such as backhoes and excavators.

19. Poison Control. Pesticides and herbicides will not be used.
20. Invasive Species Management. To reduce the spread of invasive non-native plant species and minimize the potential decrease of palatable vegetation for wildlife species, Caltrans will comply with Executive Order 13112. The purpose of this order is to prevent the introduction of invasive species and provide for their control to minimize economic, ecological, and human health impacts. In the event that high- or medium-priority noxious weeds, as defined by the California Department of Food and Agriculture or the California

Invasive Plant Council, are disturbed or removed during construction-related activities, the contractor will contain the plant material associated with these noxious weeds and will dispose of it in a manner that will not promote the spread of the species. The contractor will be responsible for obtaining all permits, licenses, and environmental clearances for properly disposing materials. Areas subject to noxious weed removal or disturbance will be replanted with fast-growing native grasses or a native erosion control seed mixture. If seeding is not possible, the area will be covered to the extent practicable with heavy black plastic solarization material until completion of construction. All earthmoving equipment, as well as seeding equipment to be used during project construction would be thoroughly cleaned before arriving on the project site.

21. Construction Site BMP's. The following site restrictions will be implemented to avoid or minimize impacts on special-status species and their habitats:
- a. Construction staging, storage, and parking areas will be located within the Caltrans ROW as described in the August 2017 BA and the December 19, 2017 reinitiation. The number and size of staging and work areas will be limited to the minimum necessary to construct the project and will be limited to existing paved surfaces or areas of compacted soil.
 - b. Routes and boundaries of roadwork will be clearly marked before the start of construction or grading.
 - c. To the maximum extent practicable, any borrow material will be certified to be nontoxic and weed free.
 - d. All food and food-related trash items will be enclosed in sealed trash containers and will be properly disposed off-site.
 - e. No pets belonging to project personnel will be allowed in the action area during construction.
 - f. No firearms will be allowed in the project footprint except for those carried by authorized security personnel, or local, State or Federal law enforcement officials.
 - g. A Spill Response Plan will be prepared. Hazardous materials (e.g., fuels, oils, solvents) will be stored in sealable containers in a designated location that is at least 100 feet from any hydrologic features.
 - h. All equipment will be properly maintained and free of leaks. Servicing of vehicles and construction equipment, including fueling, cleaning, and maintenance, will occur at least 100 feet from any hydrologic features unless it is an existing gas station.
22. Implementation of Water Quality/Erosion Control BMP's. Erosion control BMPs will be developed and implemented to minimize any wind or water-related erosion, in compliance with the requirements of the Regional Water Quality Control Board. Protective measures will include, at a minimum:
- a. No discharge of pollutants from vehicle and equipment cleaning will be allowed into any storm drains or watercourses.
 - b. Vehicle and equipment fueling and maintenance operations will be kept at least 50 feet

away from watercourses, except at established commercial gas stations or established vehicle maintenance facilities.

- c. Concrete wastes will be collected in washouts, and water from curing operations will be collected and disposed. Neither will be allowed into watercourses.
 - d. Spill containment kits will be maintained on-site at all times during construction operations and/ or staging or fueling of equipment.
 - e. Dust control measures will include use of water trucks and dust palliatives to control dust in excavation-and-fill areas, covering temporary access road entrances and exits with rock (rocking), and covering temporary stockpiles when weather conditions require.
 - f. Coir rolls or straw wattles that do not contain plastic or synthetic monofilament netting will be installed along or at the base of slopes during construction, to capture sediment.
 - g. Graded areas will be protected from erosion using a combination of silt fences and fiber rolls along toes of slopes or along edges of designated staging areas, and erosion control netting (e.g., jute or coir) will be used as appropriate on sloped areas. Erosion control materials that use plastic or synthetic monofilament netting will not be used within the BSA. This will include products that use photodegradable or biodegradable synthetic netting, which can take several months to decompose. Acceptable materials will include natural fibers, such as jute, coconut, twine or other similar fibers.
23. Replant, Reseed, and Restore Disturbed Areas. In areas of soil disturbance, any native topsoil will be removed and stored in a suitable location until project completion. Caltrans will restore temporarily disturbed areas to the preconstruction function and values to the maximum extent practicable. Exposed slopes and bare ground will be reseeded with native grasses and shrubs (using a hydro-seed mix) to stabilize and prevent erosion.
24. Service Access. If requested, before, during, or upon completion of groundbreaking and construction activities, Caltrans will allow access by Service personnel into the project footprint to inspect the project and its activities.
25. Reporting. Caltrans will submit post-construction compliance reports prepared by the Service-Approved Biological Monitor to the Service within 60 calendar days following completion of project activities or within 60 calendar days of any break in construction activity lasting more than 60 calendar days. This report will detail (1) dates that relevant project activities occurred; (2) pertinent information concerning the success of the project in implementing avoidance and minimization measures for listed species; (3) an explanation of failure to meet such measures, if any; (4) known project effects on listed species, if any; (5) occurrences of incidental take of any listed species; (6) documentation of employee environmental education; and (7) other pertinent information.

Action Area

The action area is defined in 50 CFR § 402.02, as “all areas to be affected directly or indirectly by the federal action and not merely the immediate area involved in the action.” For the proposed project, the action area encompasses a 0.63-acre construction footprint (0.53 acre for the Elliot Creek location + 0.10 acre for the Finney Creek location) plus a 300 foot habitat buffer to account for noise, vibration, and visual disturbance.

Analytical Framework for the Jeopardy Determinations

Section 7(a)(2) of the Endangered Species Act requires that federal agencies ensure that any action they authorize, fund, or carry out is not likely to jeopardize the continued existence of listed species. “Jeopardize the continued existence of” means to engage in an action that reasonably would be expected, directly or indirectly, to reduce appreciably the likelihood of both the survival and recovery of a listed species in the wild by reducing the reproduction, numbers, or distribution of that species (50 CFR § 402.02).

The jeopardy analysis in this biological opinion considers the effects of the proposed federal action, and any cumulative effects, on the range wide survival and recovery of the listed species. It relies on four components: (1) the *Status of the Species*, which describes the range wide condition of the species, the factors responsible for that condition, and its survival and recovery needs; (2) the *Environmental Baseline*, which analyzes the condition of the species in the action area, the factors responsible for that condition, and the relationship of the action area to the survival and recovery of the species; (3) the *Effects of the Action*, which determines the direct and indirect impacts of the proposed federal action and the effects of any interrelated or interdependent activities on the species; and (4) the *Cumulative Effects*, which evaluates the effects of future, non-federal activities in the action area on the species.

Analytical Framework for the Adverse Modification Determination

Section 7(a)(2) of the Act requires that federal agencies insure that any action they authorize, fund, or carry out is not likely to destroy or to adversely modify designated critical habitat. A final rule revising the regulatory definition of “destruction or adverse modification” (DAM) was published on February 11, 2016 (81 FR 7214). The final rule became effective on March 14, 2016. The revised definition states: “Destruction or adverse modification means a direct or indirect alteration that appreciably diminishes the value of critical habitat for the conservation of a listed species. Such alterations may include, but are not limited to, those that alter the physical or biological features essential to the conservation of a species or that preclude or significantly delay development of such features.”

The DAM analysis in this biological opinion relies on four components: (1) the *Status of Critical Habitat*, which describes the range-wide condition of the critical habitat in terms of the key components (i.e., essential habitat features, primary constituent elements, or physical and biological features) that provide for the conservation of the California red-legged frog, the factors responsible for that condition, and the intended value of the critical habitat overall for the conservation/recovery of the California red-legged frog; (2) the *Environmental Baseline*, which analyzes the condition of the critical habitat in the action area, the factors responsible for that condition, and the value of the critical habitat in the action area for the conservation/recovery of the California red-legged frog; (3) the *Effects of the Action*, which determines the direct and indirect impacts of the proposed federal action and the effects of any interrelated and interdependent activities on the key components of critical habitat that provide for the conservation of the California red-legged frog, and how those impacts are likely to influence the conservation value of the affected critical habitat; and (4) *Cumulative Effects*, which evaluate the effects of future non-federal activities that are reasonably certain to occur in the action area on the key components of critical habitat that provide for the conservation of the California red-legged frog and how those impacts are likely to influence the conservation value of the affected critical habitat.

For purposes of making the DAM determination, the Service evaluates if the effects of the proposed federal action, taken together with cumulative effects, are likely to impair or preclude the capacity of

critical habitat in the action area to serve its intended conservation function to an extent that appreciably diminishes the range-wide value of critical habitat for the conservation of the California red-legged frog. The key to making that finding is understanding the value (i.e., the role) of the critical habitat in the action area for the conservation/recovery of the California red-legged frog based on the *Environmental Baseline* analysis.

Status of the Species and Critical Habitat

California Red-Legged Frog

Listing Status: The California red-legged frog was listed as a threatened species on May 23, 1996 (Service 1996). Critical habitat was designated for this species on April 13, 2006 (Service 2006) and revisions to the critical habitat designation were published on March 17, 2010 (Service 2010). At this time, the Service recognized the taxonomic change from *Rana aurora draytonii* to *Rana draytonii* (Shaffer *et al.* 2010). A recovery plan was published for the California red-legged frog on September 12, 2002 (Service 2002).

Description: The California red-legged frog is the largest native frog in the western United States (Wright and Wright 1949), ranging from 1.5 to 5.1 inches in length (Stebbins 2003). The abdomen and hind legs of adults are largely red, while the back is characterized by small black flecks and larger irregular dark blotches with indistinct outlines on a brown, gray, olive, or reddish background color. Dorsal spots usually have light centers (Stebbins 2003), and dorsolateral folds are prominent on the back. Larvae (tadpoles) range from 0.6 to 3.1 inches in length, and the background color of the body is dark brown and yellow with darker spots (Storer 1925).

Distribution: The historic range of the California red-legged frog extended from the vicinity of Elk Creek in Mendocino County, California, along the coast inland to the vicinity of Redding in Shasta County, California, and southward to northwestern Baja California, Mexico (Fellers 2005; Jennings and Hayes 1985; Hayes and Krempels 1986). The species was historically documented in 46 counties but the taxa now remains in 238 streams or drainages within 23 counties, representing a loss of 70 percent of its former range (Service 2002). California red-legged frogs are still locally abundant within portions of the San Francisco Bay area and the Central California Coast. Isolated populations have been documented in the Sierra Nevada, northern Coast, and northern Transverse Ranges. The species is believed to be extirpated from the southern Transverse and Peninsular Ranges, but is still present in Baja California, Mexico (CDFW 2017).

Status and Natural History: California red-legged frogs predominately inhabit permanent water sources such as streams, lakes, marshes, natural and manmade ponds, and ephemeral drainages in valley bottoms and foothills up to 4,921 feet in elevation (Jennings and Hayes 1994, Bulger *et al.* 2003, Stebbins 2003). However, they also inhabit ephemeral creeks, drainages and ponds with minimal riparian and emergent vegetation. California red-legged frogs also can be found in disturbed areas such as channelized creeks and drainage ditches in urban and agricultural areas. For example, an adult California red-legged frog was observed in a shallow isolated pool on North Slough Creek in the American Canyon area of Napa County (C. Gaber, PG&E, pers. comm., 2008). This frog location was surrounded by vineyard development. Another adult California red-legged frog was observed under debris in an unpaved parking lot in a heavily industrial area of Burlingame (P. Kobernus, Coast Ridge Ecology, pers. comm., 2008). This frog was likely utilizing a nearby drainage ditch. Caltrans also has discovered California red-legged frog adults, tadpoles, and egg masses within a storm drainage system within a major cloverleaf intersection of Millbrae Avenue and SR 101 in a heavily developed area of San Mateo County (Caltrans 2007). California red-legged frog has the potential to persist in disturbed areas as long as those locations provide at least one or more of their life history requirements.

California red-legged frogs breed from November to April, although earlier breeding records have been reported in southern localities. Breeding generally occurs in still or slow-moving water often associated with emergent vegetation, such as cattails, tules, or overhanging willows (Storer 1925, Hayes and Jennings 1988). Female frogs deposit egg masses on emergent vegetation so that the egg mass floats on or near the surface of the water (Hayes and Miyamoto 1984).

Habitat includes nearly any area within 1-2 miles of a breeding site that stays moist and cool through the summer including vegetated areas with coyote brush, California blackberry thickets, and root masses associated with willow and California bay trees (Fellers 2005). Sheltering habitat for California red-legged frogs potentially includes landscape features that provide cover, such as animal burrows, boulders or rocks, organic debris such as downed trees or logs, and industrial debris. Agricultural features such as drains, watering troughs, spring boxes, abandoned sheds, or hay stacks may also be used. Incised stream channels with portions narrower and depths greater than 18 inches also may provide important summer sheltering habitat. Accessibility to sheltering habitat is essential for the survival of California red-legged frogs within a watershed, and can be a factor limiting frog population numbers and survival.

California red-legged frogs do not have a distinct breeding migration (Fellers 2005). Adults are often associated with permanent bodies of water. Some individuals remain at breeding sites year-round, while others disperse to neighboring water features. Dispersal distances are typically less than 0.5-mile, with a few individuals moving up to 1-2 miles (Fellers 2005). Movements are typically along riparian corridors, but some individuals, especially on rainy nights, move directly from one site to another through normally inhospitable habitats, such as heavily grazed pastures or oak-grassland savannas (Fellers 2005).

In a study of California red-legged frog terrestrial activity in a mesic area of the Santa Cruz Mountains, Bulger *et al.* (2003) categorized terrestrial use as migratory and non-migratory. The latter occurred from one to several days and was associated with precipitation events. Migratory movements were characterized as the movement between aquatic sites and were most often associated with breeding activities. Bulger *et al.* (2003) reported that non-migrating frogs typically stayed within 200 feet of aquatic habitat 90 percent of the time and were most often associated with dense vegetative cover, *i.e.*, California blackberry, poison oak and coyote brush. Dispersing frogs in northern Santa Cruz County traveled distances from 0.25 mile to more than 2 miles without apparent regard to topography, vegetation type, or riparian corridors (Bulger *et al.* 2003).

In a study of California red-legged frog terrestrial activity in a xeric environment in eastern Contra Costa County, Tatarian (2008) noted that 57 percent of frogs fitted with radio transmitters in the Round Valley study area stayed at their breeding pools, whereas 43 percent moved into adjacent upland habitat or to other aquatic sites. Her study reported a peak seasonal terrestrial movement occurring in the fall months associated with the first 0.2 inch of precipitation and tapering off into spring. Upland movement activities ranged from 3 to 233 feet, averaging 80 feet, and were associated with a variety of refugia including grass thatch, crevices, cow hoof prints, ground squirrel burrows at the base of trees or rocks, logs, and under man-made structures; others were associated with upland sites lacking refugia (Tatarian 2008). The majority of terrestrial movements lasted from 1 to 4 days; however, one adult female was reported to remain in upland habitat for 50 days (Tatarian 2008). Upland refugia closer to aquatic sites were used more often and were more commonly associated with areas exhibiting higher object cover, *e.g.*, woody debris, rocks, and vegetative cover. Subterranean cover was not significantly different between occupied upland habitat and non-occupied upland habitat.

California red-legged frogs are often prolific breeders, laying their eggs during or shortly after large rainfall events in late winter and early spring (Hayes and Miyamoto 1984). Egg masses containing 2,000-5,000 eggs are attached to vegetation below the surface and hatch after 6-14 days (Storer 1925, Jennings and Hayes 1994). In coastal lagoons, the most significant mortality factor in the pre-hatching stage is water salinity (Jennings *et al.* 1992). Eggs exposed to salinity levels greater than 4.5 parts per thousand resulted in 100 percent mortality (Jennings and Hayes 1990). Increased siltation during the breeding season can cause asphyxiation of eggs and small larvae. Larvae undergo metamorphosis 3.5-7 months following hatching and reach sexual maturity at 2 - 3 years of age (Storer 1925; Wright and Wright 1949; Jennings and Hayes 1985, 1990, 1994). Of the various life stages, larvae probably experience the highest mortality rates, with less than 1 percent of eggs laid reaching metamorphosis (Jennings *et al.* 1992). California red-legged frogs may live 8 to 10 years (Jennings *et al.* 1992). Populations can fluctuate from year to year; favorable conditions allow the species to have extremely high rates of reproduction and thus produce large numbers of dispersing young and a concomitant increase in the number of occupied sites. In contrast, the animal may temporarily disappear from an area when conditions are stressful (*e.g.*, during periods of drought, disease, etc.).

The diet of California red-legged frogs is highly variable and changes with the life history stage. The diet of the larvae is not well studied, but is likely similar to that of other ranid frogs, which feed on algae, diatoms, and detritus by grazing on the surface of rocks and vegetation (Fellers 2005; Kupferberg 1996a, 1996b, 1997). Hayes and Tennant (1985) analyzed the diets of California red-legged frogs from Cañada de la Gaviota in Santa Barbara County during the winter of 1981 and found invertebrates (comprising 42 taxa) to be the most common prey item consumed; however, they speculated that this was opportunistic and varied based on prey availability. They ascertained that larger frogs consumed larger prey and were recorded to have preyed on Pacific chorus frogs, three-spined stickleback, and, to a limited extent, California mice, which were abundant at the study site (Hayes and Tennant 1985, Fellers 2005). Although larger vertebrate prey was consumed less frequently, it represented over half of the prey mass eaten by larger frogs suggesting that such prey may play an energetically important role in their diets (Hayes and Tennant 1985). Juvenile and subadult/adult frogs varied in their feeding activity periods; juveniles fed for longer periods throughout the day and night, while subadult/adults fed nocturnally (Hayes and Tennant 1985). Juveniles were significantly less successful at capturing prey and all life history stages exhibited poor prey discrimination, feeding on several inanimate objects that moved through their field of view (Hayes and Tennant 1985).

Recovery Plan: The recovery plan for the California red-legged frog identifies eight recovery units (Service 2002). The establishment of these recovery units is based on the determination that various regional areas of the species' range are essential to its survival and recovery. The status of the California red-legged frog was considered within the small scale recovery units as opposed to their overall range. These recovery units are delineated by major watershed boundaries as defined by U.S. Geological Survey hydrologic units and the limits of its range. The goal of the recovery plan is to protect the long-term viability of all extant populations within each recovery unit. Within each recovery unit, core areas have been delineated and represent contiguous areas of moderate to high California red-legged frog densities that are relatively free of exotic species such as bullfrogs. The goal of designating core areas is to protect metapopulations. Thus when combined with suitable dispersal habitat, will allow for the long term viability within existing populations. The management strategy identified within the Recovery Plan will allow for the recolonization of habitats within and adjacent to core areas that are naturally subjected to periodic localized extinctions, thus assuring the long-term survival and recovery of California red-legged frogs

Threats: Habitat loss, non-native species introduction, and urban encroachment are the primary factors that have adversely affected the California red-legged frog throughout its range. Several researchers in central California have noted the decline and eventual local disappearance of California and northern red-legged frogs in systems supporting bullfrogs (Jennings and Hayes 1990, Twedt 1993), red swamp crayfish, signal crayfish, and several species of warm water fish including sunfish, goldfish, common carp, and mosquitofish (Moyle 1976, Barry 1992, Hunt 1993, Fisher and Schaffer 1996). This has been attributed to predation, competition, and reproduction interference. Twedt (1993) documented bullfrog predation of juvenile northern red-legged frogs, and suggested that bullfrogs could prey on subadult California red-legged frogs as well. Bullfrogs may also have a competitive advantage over California red-legged frogs. For instance, bullfrogs are larger and possess more generalized food habits (Bury and Whelan 1984). In addition, bullfrogs have an extended breeding season (Storer 1933) during which an individual female can produce as many as 20,000 eggs (Emlen 1977). Furthermore, bullfrog larvae are unpalatable to predatory fish (Kruse and Francis 1977). Bullfrogs also interfere with California red-legged frog reproduction by eating adult male California red-legged frogs. Both California and northern red-legged frogs have been observed in amplexus (mounted on) with both male and female bullfrogs (Jennings and Hayes 1990, Jennings 1993, Twedt 1993). Thus bullfrogs are able to prey upon and out-compete California red-legged frogs, especially in sub-optimal habitat.

The urbanization of land within and adjacent to California red-legged frog habitat has also affected the threatened amphibian. These declines are attributed to channelization of riparian areas, enclosure of the channels by urban development that blocks dispersal, and the introduction of predatory fishes and bullfrogs. Diseases may also pose a significant threat, although the specific effects of disease on the California red-legged frog are not known. Pathogens are suspected of causing global amphibian declines (Davidson *et al.* 2003). Chytridiomycosis and ranaviruses are a potential threat because these diseases have been found to adversely affect other amphibians, including the listed species (Davidson *et al.* 2003; Lips *et al.* 2006). Mao *et al.* (1999 cited in Fellers 2005) reported northern red-legged frogs infected with an iridovirus, which was also presented in sympatric threespine sticklebacks in northwestern California. Non-native species, such as bullfrogs and non-native tiger salamanders that live within the range of the California red-legged frog have been identified as potential carriers of these diseases (Garner *et al.* 2006). Human activities can facilitate the spread of disease by encouraging the further introduction of non-native carriers and by acting as carriers themselves (*i.e.*, contaminated boots, waders or fishing equipment). Human activities can also introduce stress by other means, such as habitat fragmentation, that results in the listed species being more susceptible to the effects of disease.

Negative effects to wildlife populations from roads and pavement may extend some distance from the actual road. The phenomenon can result from any of the effects already described in this Biological Opinion, such as vehicle-related mortality, habitat degradation, and invasive exotic species. Forman and Deblinger (1998, 2000) described the area affected as the “road effect” zone. Along a four-lane road in Massachusetts, they determined that this zone extend for an average of approximately 980 feet to either side of the road for an average total zone width of approximately 1,970 feet. They describe the boundaries of this zone as asymmetric and in some areas diminished wildlife use attributed to road effects was detected greater than 0.6 mile from Massachusetts Route 2. The “road-zone” effect can also be subtle. Van der Zande *et al.* (1980) reported that lapwings and black-tailed godwits feeding at 1,575-6,560 feet from roads were disturbed by passing vehicles. The heart rate, metabolic rate and energy expenditure of female bighorn sheep increase near roads (MacArthur *et al.* 1979). Trombulak and Frissell (2000) described another type of “road-zone” effect due to contaminants. Heavy metal concentrations from vehicle exhaust were greatest within 66 feet of roads, but elevated levels of metals in both soil and plants were detected at 660 feet of roads. The “road-zone” apparently varies with habitat type and traffic volume. Based on responses by birds,

Forman (2000) estimated the effect zone along primary roads of 1,000 feet in woodlands, 1,197 feet in grasslands, and 2,657 feet in natural lands near urban areas. Along secondary roads with lower traffic volumes, the effect zone was 656 feet. The “road-zone” effect with regard to California red-legged frogs has not been adequately investigated.

The necessity of moving between multiple habitats and breeding ponds means that many amphibian species, such as the California red-legged frog, are especially vulnerable to roads and well-used large paved areas in the landscape. Van Gelder (1973) and Cooke (1995) have examined the effect of roads on amphibians and found that because of their activity patterns, population structure, and preferred habitats, aquatic breeding amphibians are more vulnerable to traffic mortality than some other species. Large, high-volume highways pose a nearly impenetrable barrier to amphibians and result in mortality to individual animals as well as significantly fragmenting habitat. Hels and Buchwald (2001) found that mortality rates for anurans on high traffic roads are higher than on low traffic roads. Vos and Chardon (1998) found a significant negative effect of road density on the occupation probability of ponds by the moor frog (*Rana arvalis*) in the Netherlands. In addition, incidents of very large numbers of road-killed frogs are well documented (*e.g.*, Ashley and Robinson 1996), and studies have shown strong population level effects of traffic density (Carr and Fahrig 2001) and high traffic roads on these amphibians (Van Gelder 1973; Vos and Chardon 1998). Most studies regularly count road kills from slow moving vehicles (Hansen 1982; Rosen and Lowe 1994; Drews 1995; Mallick *et al.* 1998) or by foot (Munguira and Thomas 1992). These studies assume that every victim is observed, which may be true for large conspicuous mammals, but it certainly is not true for small animals, such as the California red-legged frog. Amphibians appear especially vulnerable to traffic mortality because they readily attempt to cross roads, are slow-moving and small, and thus cannot easily be avoided by drivers (Carr and Fahrig 2001).

Critical Habitat Status for the California Red-Legged Frog

Critical habitat is defined in Section 3 of the Act as: (1) The specific areas within the geographical area occupied by a species, at the time it is listed in accordance with the Act, on which are found those physical or biological features (a) essential to the conservation of the species and (b) that may require special management considerations or protection; and (2) specific areas outside the geographical area occupied by a species at the time it is listed, upon a determination that such areas are essential for the conservation of the species. In determining which areas to designate as critical habitat, the Service considers those physical and biological features that are essential to a species' conservation and that may require special management considerations or protection (50 CFR 424.12(b)).

The Service designated critical habitat for the California red-legged frog on April 13, 2006 (71 FR 19244) (Service 2006a) and a revised designation to the critical habitat was published on March 17, 2010 (75 FR 12816) (Service 2010).

The PCE's defined for the California red-legged frog provide aquatic habitat for breeding and non-breeding activities and upland habitat for shelter, foraging, predator avoidance, and dispersal across its range. The PCE's and, therefore, the resulting physical and biological features essential for the conservation of the species were determined from studies of California red-legged frog ecology. Based on the above needs and our current knowledge of the life history, biology, and ecology of the species, and the habitat requirements for sustaining the essential life-history functions of the species, the Service determined that the PCE's essential to the conservation of the California red-legged frog are:

1. Aquatic Breeding Habitat. Standing bodies of fresh water (with salinities less than 7.0 parts per thousand), including: natural and manmade (*e.g.*, stock) ponds, slow-moving streams or

pools within streams, and other ephemeral or permanent water bodies that typically become inundated during winter rains and hold water for a minimum of 20 weeks in all but the driest of years.

2. Non-Breeding Aquatic Habitat. Freshwater and wetted riparian habitats, as described above, that may not hold water long enough for the subspecies to hatch and complete its aquatic life cycle but that do provide for shelter, foraging, predator avoidance, and aquatic dispersal for juvenile and adult California red-legged frogs. Other wetland habitats that would be considered to meet these elements include, but are not limited to: plunge pools within intermittent creeks; seeps; quiet water refugia during high water flows; and springs of sufficient flow to withstand the summer dry period.
3. Upland Habitat. Upland areas adjacent to or surrounding breeding and non-breeding aquatic and riparian habitat up to a distance of 1 mile in most cases and comprised of various vegetational series such as grasslands, woodlands, wetland, or riparian plant species that provide the frog shelter, forage, and predator avoidance. Upland features are also essential in that they are needed to maintain the hydrologic, geographic, topographic, ecological, and edaphic features that support and surround the wetland or riparian habitat. These upland features contribute to the filling and drying of the wetland or riparian habitat and are responsible for maintaining suitable periods of pool inundation for larval frogs and their food sources, and provide breeding, non-breeding, feeding, and sheltering habitat for juvenile and adult frogs (e.g., shelter, shade, moisture, cooler temperatures, a prey base, foraging opportunities, and areas for predator avoidance). Upland habitat should include structural features such as boulders, rocks and organic debris (e.g., downed trees, logs), as well as small mammal burrows and moist leaf litter.
4. Dispersal Habitat. Accessible upland or riparian dispersal habitat within designated units and between occupied locations within a minimum of 1 mile of each other that allow for movement between such sites. Dispersal habitat includes various natural habitats and altered habitats such as agricultural fields, which do not contain barriers (e.g., heavily traveled road without bridges or culverts) to dispersal. Dispersal habitat does not include moderate- to high-density urban or industrial developments with large expanses of asphalt or concrete, nor does it include large reservoirs over 50 acres in size, or other areas that do not contain those features identified by PCE's 1, 2, or 3 as essential to the conservation of the subspecies.

With the revised designation of critical habitat, the Service intends to conserve the geographic areas containing the physical and biological features that are essential to the conservation of the species, through the identification of the appropriate quantity and spatial arrangement of the PCE's sufficient to support the life-history functions of the species. Because not all life-history functions require all the PCE's, not all areas designated as critical habitat will contain all the PCE's. Refer to the final designation of critical habitat for California red-legged frog for additional information (75 FR 12816).

San Francisco Garter Snake

For the most recent comprehensive assessment of the San Francisco garter snake's range-wide status, please refer to the species' 2006 *5-Year Review* (Service 2006b). The *5-Year Review* does not include the threat, recovery, survey data, and other relevant updates for the species since its issuance. Since that time, actions have been implemented that have resulted in additional adverse effects to the species. In association with those actions, conservation measures have been implemented for the purpose of minimizing those adverse effects and in some cases, conserving, restoring, or enhancing

San Francisco garter snake habitat. While the threats posed by habitat destruction and modification as well as other factors including curtailment of habitat or range; overutilization for commercial, recreational, scientific, or educational purposes; and disease or predation are ongoing, to date no project has proposed a level of effects for which the Service has issued a biological opinion of jeopardy for the species.

Environmental Baseline

The action area is located along the Central Pacific Coast, situated between the Pacific Ocean and the Santa Cruz Mountains. The area experiences a moderate climate which includes cool and moist fog throughout the summer. The local landscape is characterized by steep to rolling topography vegetated by open grasslands, forests, woodlands, scrub, and riparian corridors.

There is little development in the local area. The project is located entirely within the Caltrans ROW, which is bordered to the east by private land utilized for row crops and grazing. Elliot and Finney Creeks are neighboring drainages, separated by a ridgeline. Big Basin Redwoods State Park is located approximately 0.37 mile east of the proposed Elliot Creek location footprint and 0.56 mile east of the Finney Creek location and includes the majority of both creeks' watersheds. An additional segment of the Big Basin Redwoods State Park is located approximately 0.32 mile down the coast line from the Elliot Creek location. Ano Nuevo State Park is located approximately 0.13 mile north, up the coast line from the footprint of the proposed Finney Creek location.

There are numerous drainages in the general vicinity, flowing westward down from the Santa Cruz Mountains. Nearby named creeks include Ano Nuevo Creek, approximately 0.33 mile north of the Finney Creek location; as well as Waddell Creek, approximately 1.4 miles south of the Elliot Creek location.

California Red-Legged Frog

The action area is located within the range of the California red-legged frog. A map depicting the species' range is included in the Service's online profile for the species at <http://ecos.fws.gov/speciesProfile/profile/speciesProfile.action?spcode=D02D>.

The proposed project is within California Red-Legged Frog Recovery Unit 5 (Central Coast) (Service 2002). The action area is located within Core Area #21 (South San Francisco Bay) of that Recovery Unit (Service 2002). The conservation needs for the South San Francisco Bay Core Area are: (1) protect existing populations, (2) control non-native predators, increase connectivity between populations, (3) reduce erosion, (4) implement guidelines for recreation activities to reduce impacts, (5) implement forest practice guidelines, and (6) reduce impacts of urbanization. This core area is described in the recovery plan as an important source population for the species.

Caltrans did not conduct standardized or protocol frog or other wildlife surveys in the action area or a wildlife movement analysis to support their baseline analysis for the project. However, occurrence of the listed frog has been well documented in the nearby area, particularly within the nearby Ano Nuevo and Big Basin Redwoods State Parks where there is active management for the benefit of the listed frog (California State Parks 2008 and 2013). The California red-legged frog is relatively abundant within this segment of the Coast Range. Compared to other portions of their historic range, habitat loss and degradation has been low to moderate in the project vicinity.

There may be seasonal habitat features within Elliot Creek and Finney Creek, and other nearby drainages such as backwater or plunge pools that are conducive to successful California red-legged frog breeding in favorable years. A large number of California red-legged frogs have been

documented within the Waddell Creek system (CNDDDB occurrence 471, CDFW 2017) in land managed by Big Basin Redwoods State Park and their larvae are likely developing within the creek or other nearby aquatic habitat. Breeding is also occurring in a pond adjacent to the Ano Nuevo State Park visitor center, approximately 0.62 mile from the Finney Creek location and approximately 0.96 mile from the Elliot Creek location (CNDDDB occurrence 573, CDFW 2017). The Coastways Reservoir is located approximately 0.17 mile north of the Finney Creek location and approximately 0.49 mile north of the Elliot Creek location with frog breeding potential. The reservoir is within the Coastways Ranch, an organic berry and kiwi farm.

The California red-legged frog has the potential to be encountered in upland habitat throughout the action area. Although the majority of individuals likely reside nearby freshwater aquatic features; cool temperatures, summer fog, and vegetative shade make upland areas hospitable for frog occupation throughout the year in this area for refuge, movement, and foraging. Frogs may be encountered both in the open or taking cover under vegetation, in burrows or soil cracks, under various debris, and under staged equipment or construction materials.

SR 1 is likely a fragmenting feature for upland connectivity, not due to physical barriers but from road mortality. Although most crossing attempts are likely successful, over time the compounded mortality can have a significant effect on population viability as the integrity of the larger population is disrupted and the recovery goals for the species in the South San Francisco Bay Core Recovery Unit are compromised.

There are a few local cross culverts under SR 1 but it is uncertain if they are suitable to provide safe passage for the California red-legged frog. Although frogs may be washed down through it, the SR 1 Elliot Creek and Finney Creek culverts do not appear to be conducive to intentional movement. The Elliot Creek culvert outlet is suspended and empties into a dissipation area before dropping in a falls over the bluff to the beach below. Local movements across SR 1 would most likely take place over the road surface, exposing them to risk. Without a road mortality study or movement analysis it is difficult to determine the “hot spots” for red-legged frog movement across SR 1, and hence where increased road mortality risk would occur. Little roadkill data is available for this section of SR 1 on the University of California at Davis Road Ecology Center’s online California Roadkill Observation System (<http://www.wildlifecrossing.net/california/>).

The road effects zone applies to the California red-legged frog and in this case, SR 1 is a permeable barrier to east and west movement due to road mortality. This baseline condition likely creates a risk for California red-legged frog that diminishes with distance from the SR 1 travel corridor and surrounding roads. Beyond road mortality, risks can also include adverse effects generated from traffic related noise, exhaust, head lighting, heavy metal and other solid deposition, toxic liquid discharges, and discarded waste. Chemicals also leach from pavement and are transported into the local environment. Paved surfaces absorb and reflect heat, creating elevated heat “islands”. It is also likely that noxious weeds are introduced or spread to the SR 1 ROW and surrounding environment through deposition from passing vehicles.

Adult California red-legged frogs are highly mobile and have been documented to move more than 2 miles over upland habitat. The frog habitat within the action area has direct connectivity with suitable habitat adjacent to the project site and is well within the feasible movement distance to potential breeding locations. Vertical barriers can limit or prevent passage but California red-legged frogs are not adverse to steep topography and could move back and forth between the action area and nearby ponds in the vicinity by way of the grassland, row crops, woodland, riparian, and scrub habitat as well as several ephemeral drainages.

The Service believes that the California red-legged frog is reasonably certain to occur within the action area due to: (1) the project being located within the species' range and current distribution; (2) suitable upland habitat within the action area; (3) local abundance and recorded occurrences nearby; (4) all the elements needed to support the species' life history are located within 0.17-mile of the action area; (5) the lack of significant disturbance or history of significant threats to the species in the general vicinity; (6) the ability of the animal to move long distances; (7) active monitoring, management, and conservation for the species in nearby public lands; and (8) the biology and ecology of the animal.

California Red-Legged Frog Critical Habitat

All 1.06 acres of the project footprint is within California red-legged frog critical habitat unit SCZ-1. Also known as the North Coastal Santa Cruz County Unit, SCZ-1 is comprised of approximately 72,255 acres along the Santa Cruz County coast line and the southwest end of San Mateo County. The unit overlays federal (226 acres), State (20,562 acres), and private (51,460 acres) lands. SCZ-1 is currently occupied by the California red-legged frog and was mapped based on frog occurrences. The unit contains high-quality California red-legged frog habitat, representing all four PCEs. The unit also provides connectivity between occupied sites along the coast and further inland.

As stated in the designation, the physical and biological features essential to the conservation of California red-legged frog in the SCZ-1 unit may require special management considerations or protection due to water diversions, which may alter aquatic habitats and thereby result in the direct or indirect loss of egg masses, juveniles, or adults.

San Francisco Garter Snake

The action area is within the historic range of the San Francisco garter snake. A map depicting the species' range is included in the Service's online profile for the species at <https://ecos.fws.gov/ecp0/profile/speciesProfile?sId=5956#currentRange>.

Although the Service acknowledges the difficulty in estimating the listed snakes' current population, the individuals that occupy Ano Nuevo State Park are identified as one the six "significant" populations in the species' recovery plan (Service 1985). One of the objectives of the recovery plan is to monitor and manage the park for the listed snake. As mentioned in the previous section for the California red-legged frog, both Ano Nuevo and Big Basin Redwoods support a stable population of San Francisco garter snakes and actively manage for its conservation (California State Parks 2008 and 2013). As described in the species' *5-Year Review*, Ano Nuevo State Park may contain one of the largest known San Francisco garter snake populations (Service 2006b). It has been concluded that the high densities of the snake in Ano Nuevo State Park are likely due to an abundance of freshwater wetlands and suitable upland foraging habitats available for their prey.

The California red-legged frog is a noted prey item for the San Francisco garter snake and the CNDDDB includes co-occurrence records of the two species, where their ranges overlap. Such is the case of the occurrences described in the California red-legged frog section in Ano Nuevo and Big Basin Redwoods State Parks (CNDDDB occurrences 14 and 30, CDFW 2017). Sean Barry described the Coastways Reservoir, referenced in the California red-legged frog section, approximately 0.17 mile north of the Finney Creek location and approximately 0.49 mile north of the Elliot Creek location as the site of a likely San Francisco garter snake population (CNDDDB occurrence 73, CDFW 2017).

Based on what is known about this species' life history, evidence suggests that San Francisco garter snakes typically stay within 0.6 mile of aquatic habitat (Service 2006b). However, individuals do disperse through upland habitat and likely spend more time foraging away from aquatic habitat

during the dry season as their frog prey metamorphose and wetlands and other ephemeral water sources dry up. Upland travel is also important for individuals to disperse to other suitable habitats. Therefore, the listed snake may be encountered in the project footprint dispersing or in search of prey (which includes the California red-legged frog).

The San Francisco garter snake experiences the same road-related risks described for the California red-legged frog. As noted in the snake's 5-year review, the San Francisco garter snake likely uses roads for thermoregulation, placing it at greater risk of vehicle collision (Service 2006b). The species has been observed basking on roads and road kill carcasses have been found at Ano Nuevo State Park (Service 2006b).

The Service believes that the San Francisco garter snake is likely to be present within the action area due to: (1) the project being located within the species' range and current distribution; (2) suitable upland habitat within the action area; (3) local abundance and recorded occurrences nearby; (4) all the elements needed to support the species' life history are located within the action area; (5) the lack of significant disturbance or history of significant threats to the species in the general vicinity; (6) active monitoring, management, and conservation for the species in nearby public lands; and (7) the biology and ecology of the animal.

Effects of the Action

The direct effects of the proposed project are those effects occurring within the action area during construction of the proposed project. For this project the direct effects are primarily associated with the excavation of the slip out and all other ground work outside the paved area. The effects of disturbance were analyzed based on the term of the habitat loss, restoration potential, and the associated changes to functional value. As a result, habitat loss was characterized as permanent or temporary. The majority of the 0.63-acre project footprint is located on existing pavement and compact road shoulder. According to the August 2017 BA and December 22, 2017, e-mail message, ground disturbance will amount to approximately 0.04 acre of non-pavement or compact soil landscape (0.03 acre at the Elliot Creek location + 0.01 acre at the Finney Creek location), encompassing the slip-out repair in addition to the berm, dike, down drain, and rock pad construction. This area is vegetated with annual vegetation and woody shrubs (primarily poison oak). Although the slip-out at the Elliot Creek location will be excavated and filled with RSP, it will be capped with native topsoil and hydroseeded. The dikes at both locations will be lined with asphalt concrete. Hydroseed will be applied to the earthen berm at the Elliot Creek location and all other disturbed areas that will remain as exposed landscape. This work will involve modification of the baseline topography, but with the exception of the dike, the area is likely to provide vegetative cover in less than one year following initial disturbance. Permanent effects would likely be limited to the dikes due to the introduction on an impervious surface. However, the dikes will be narrow and will likely fill with sediment and overhanging vegetation within less than 5 years. The dikes are not expected to create a movement barrier or limit the California red-legged frog's ability use of the surrounding upland habitat.

Indirect effects are the effects of the proposed project generally occurring later in time after construction has been completed (*e.g.*, degradation of habitat due to the spread of invasive plant species; barriers to dispersal due to the installation of retaining walls). An interrelated activity is an activity that is part of the proposed project and depends on the proposed project for its justification. An interdependent activity is an activity that has no independent utility apart from the action under consultation.

California Red-Legged Frog and San Francisco Garter Snake

Caltrans proposes to minimize construction related effects by implementing the *Conservation Measures* included in the project description section of this biological opinion. Effective implementation of *Conservation Measures* will likely minimize adverse effects to the California red-legged frog and San Francisco garter snake during construction. The proposed project has the potential to result in a variety of adverse effects to these two species, combined in the following section based on the similarities.

The California red-legged frog and San Francisco garter snake could be encountered throughout the hardscape and landscape areas of the project footprint where they risk injury under staged and moving equipment/vehicles and ground disturbing activities.

Educating project personnel will encourage compliance with the conservation measures and increase the possibility that California red-legged frogs and San Francisco garter snakes in the work area will be identified and addressed appropriately for avoidance. Worker education is limited by the effectiveness of the presentation and the willingness of the construction personnel to participate in compliance.

Pre-construction surveys by a Service-Approved Biological Monitor will assist in clearing California red-legged frogs and San Francisco garter snakes from the work area prior to the introduction of a potential construction-related threat. Biological clearance of work areas prior to the start of each day's work and during construction will increase the chances of identifying frogs and snakes in the work area that would be susceptible to injury. Biological clearance of work areas is limited by the experience of the biologist, the complexity and abundance of potential cover sites, the small size and inconspicuous nature of the species, and the challenges of completing a thorough clearance given the construction schedule, the steepness of the topography, and the presence of poison oak vegetation.

Despite being "cleared" prior to construction, California red-legged frogs and San Francisco garter snakes may move into the work site undetected and could be adversely affected by the activities occurring within.

Monitoring and covering steep-walled excavations should minimize the potential for the two listed species to be affected by predation, desiccation, entombment, or starvation. Proper trash disposal is often difficult to enforce and is a common non-compliance issue. Improperly disposed edible trash could attract predators, such as raccoons, crows, and ravens, to the site, which could subsequently prey on the California red-legged frog and San Francisco garter snake. Trapped red-legged frogs may also be vulnerable to predation from the San Francisco garter snake.

If unrestricted, biologists, construction workers, and in-creek equipment traveling to the action area from other project sites may transmit diseases by introducing contaminated equipment. The chance of a disease being introduced into a new area is greater today than in the past due to the increasing occurrences of disease throughout amphibian populations in California and the United States. It is possible that chytridiomycosis, caused by chytrid fungus, may exacerbate the effects of other diseases on amphibians or increase the sensitivity of the amphibian to environmental changes (*e.g.*, water pH) that reduce normal immune response capabilities (Bosch *et al.* 2001, Weldon *et al.* 2004). Infection is an obvious threat to the California red-legged frog but can also adversely affect the San Francisco garter snake by eliminating its amphibian prey.

Discovery, capture, and relocation of individual California red-legged frogs and San Francisco garter snakes may avoid injury or mortality due to construction activities; however, capturing and handling animals may result in stress and/or inadvertent injury during handling, containment, and transport.

California red-legged frogs, San Francisco garter snakes, and their prey could also be affected by contamination due to chemical or sediment discharge. Exposure pathways could include inhalation, dermal contact, direct ingestion, or secondary ingestion of contaminated soil, plants or prey species. Exposure to contaminants could cause short- or long-term morbidity, possibly resulting in reduced productivity or mortality. However, Caltrans proposes to reduce these risks by limiting the equipment used in the stream bed to hand tools, implementing BMPs that consist of refueling, oiling, or cleaning of vehicles and equipment a minimum of 50 feet from riparian and aquatic areas (or utilizing pads or other catchments to avoid potential discharges in cases where equipment cannot be moved); installing coir rolls, straw wattles and/or silt fencing to capture sediment and prevent runoff or other harmful chemicals from entering the aquatic habitat; and locating staging, storage and parking areas away from aquatic habitat.

Caltrans' commitment to use erosion control devices other than mono-filament should be effective in avoiding the associated risk of entrapment that can result in death by predation, starvation, or desiccation (Stuart *et al.* 2001).

The completed project is unlikely to increase the local risk of California red-legged frog and San Francisco garter snake mortality from vehicle collision. The completed project will not provide wildlife with greater access to the roadway or result in the addition of structures such as barriers that may result in greater risk of being stranded in the roadway increasing their risk of being killed. Likewise, the road effects zone described in the baseline section is unlikely to change.

Repairing the slip out will assist in stabilizing the bluff. Given the planned restoration, which includes capping the RSP with native soil, it is likely that the disturbed area will reach baseline ecological values within five years of construction.

California Red-Legged Frog Critical Habitat

Implementation of the proposed project will involve disturbance of approximately 0.04 acre of non-hardscape, upland habitat. The disturbed upland habitat component (PCE 3) is expected to regain baseline values within 5 years due to capping RSP with native soil and revegetation measures. The dispersal function (PCE 4) of the project footprint will be retained post-construction. The project is not expected to have any effects on aquatic habitat (PCEs 1 and 2). Therefore, the action is not expected to diminish the value of the critical habitat for the California red-legged frog, or prevent critical habitat from sustaining its role in the conservation and recovery of the species.

Cumulative Effects

Cumulative effects include the effects of future State, Tribal, local or private actions that are reasonably certain to occur in the action area considered in this Biological Opinion. Future federal actions that are unrelated to the SR 1 Elliot Creek and Finney Creek Storm Damage Project are not considered in this section because they require separate consultation pursuant to section 7 of the Act. During this consultation, the Service did not identify any future non-federal actions that are reasonably certain to occur in the action area of the proposed project.

Conclusion

After reviewing the current status of the California red-legged frog and San Francisco garter snake, the environmental baseline for the action area, the effects of the proposed SR 1 Elliot Creek and Finney Creek Storm Damage Project, and the cumulative effects, it is the Service's biological opinion that the SR 1 Elliot Creek and Finney Creek Storm Damage Project, as proposed, is not likely to jeopardize the continued existence of the California red-legged frog and San Francisco garter snake. The Service reached this conclusion because the project-related effects to the species, when added to the environmental baseline and analyzed in consideration of all potential cumulative effects, will not rise to the level of precluding recovery or reducing the likelihood of survival of the species based on the following: (1) successful implementation of the described *Conservation Measures* is likely to reduce the potential for proposed project activities to result in the disruption of normal California red-legged frog and San Francisco garter snake behavior or risk of injury; (2) the project will not result in significant habitat loss to either species; and (3) the project will be completed within a short period of time which will limit the risk of adverse construction-related effects and hasten restoration of affected areas.

After reviewing the current status of designated critical habitat for the California red-legged frog, the environmental baseline for the action area, the effects of the proposed SR 1 Elliot Creek and Finney Creek Storm Damage Project, and the cumulative effects, it is the Service's biological opinion that the SR 1 Elliot Creek and Finney Creek Storm Damage Project, as proposed, is not likely to destroy or adversely modify designated critical habitat for the California red-legged frog. The Service reached this conclusion because the project-related effects to the designated critical habitat, when added to the environmental baseline and analyzed in consideration of all potential cumulative effects, will not rise to the level of precluding the function of the critical habitat to serve its intended conservation role for the California red-legged frog. The project will not result in any effects to the defined PCEs of California red-legged frog critical habitat and therefore will not diminish the value of the critical habitat or prevent it from sustaining its role in the conservation of the California red-legged frog.

INCIDENTAL TAKE STATEMENT

Section 9 of the Act and federal regulation pursuant to section 4(d) of the Act prohibit the take of endangered and threatened species, respectively, without special exemption. Take is defined as to harass, harm, pursue, hunt, shoot, wound, kill, trap, capture or collect, or to attempt to engage in any such conduct. Harass is defined by Service regulations at 50 CFR 17.3 as an intentional or negligent act or omission which creates the likelihood of injury to wildlife by annoying it to such an extent as to significantly disrupt normal behavior patterns which include, but are not limited to, breeding, feeding, or sheltering. Harm is defined by the same regulations as an act which actually kills or injures wildlife. Harm is further defined to include significant habitat modification or degradation that results in death or injury to listed species by significantly impairing essential behavior patterns, including breeding, feeding, or sheltering. Incidental take is defined as take that is incidental to, and not the purpose of, the carrying out of an otherwise lawful activity. Under the terms of section 7(b)(4) and section 7(o)(2), taking that is incidental to and not intended as part of the agency action is not considered to be prohibited taking under the Act provided that such taking is in compliance with the terms and conditions of this *Incidental Take Statement*.

In June 2015, the Service finalized new regulations implementing the incidental take provisions of section 7(a)(2) of the Act. The new regulations also clarify the standard regarding when the Service formulates an *Incidental Take Statement* [50 CFR 402.14(g)(7)], from "...if such take may occur" to "...if such take is reasonably certain to occur." This is not a new standard, but merely a clarification

and codification of the applicable standard that the Service has been using and is consistent with case law. The standard does not require a guarantee that take will result; only that the Service establishes a rational basis for a finding of take. The Service continues to rely on the best available scientific and commercial data, as well as professional judgment, in reaching these determinations and resolving uncertainties or information gaps.

The measures described below are non-discretionary, and must be undertaken by the Caltrans so that they become binding conditions of any grant or permit issued to the applicant, as appropriate, for the exemption in section 7(o)(2) to apply. The Caltrans has a continuing duty to regulate the activity covered by this incidental take statement. If the Caltrans (1) fails to assume and implement the terms and conditions or (2) fails to require the applicant to adhere to the terms and conditions of the incidental take statement through enforceable terms that are added to the permit or grant document, the protective coverage of section 7(o)(2) may lapse. In order to monitor the impact of incidental take, Caltrans must report the progress of the action and its impact on the species to the Service as specified in the incidental take statement [50 CFR §402.14(i)(3)].

Amount or Extent of Take

California Red-Legged Frog

The Service anticipates that incidental take of the California red-legged frog will be difficult to detect due to their small size, wariness, and cryptic nature. The project footprint includes vegetative cover, rocks, and debris which provide cover for the California red-legged frog. The proposed work area includes dense scrub upland California red-legged habitat on a slope that will be difficult to survey or inspect following ground disturbance, making the living frogs or their carcasses difficult to find. Furthermore, finding an injured or dead California red-legged frog is unlikely due to their relatively small body size, rapid carcass deterioration, and likelihood that the remains will be removed by a scavenger or indistinguishable amongst the disturbed soil and debris. Losses of the California red-legged frog may also be difficult to quantify due to a lack of baseline survey data and seasonal/annual fluctuations in their numbers due to environmental or human-caused disturbances. There is a risk of harm, harassment, injury and mortality as a result of the proposed construction activities, the temporary loss/degradation of suitable habitat, and capture and relocation efforts; therefore, the Service is authorizing take incidental to the proposed action as: (1) the harassment of all California red-legged frogs within the action area; (2) the capture and relocation of all California red-legged frogs within the 0.63-acre project footprint; and (3) the injury or mortality of one adult or juvenile California red-legged frog.

San Francisco Garter Snake

The Service anticipates that incidental take of the San Francisco garter snake will be difficult to detect due to their small size. The project footprint includes vegetative cover, rocks, and debris which provide cover for the San Francisco garter snake. The proposed work area includes dense scrub upland San Francisco garter snake habitat on a slope that will be difficult to survey or inspect following ground disturbance, making the living snakes or their carcasses difficult to find. Furthermore, finding an injured or dead San Francisco garter snake is unlikely due to their relatively small body size, rapid carcass deterioration, and likelihood that the remains will be removed by a scavenger or indistinguishable amongst the disturbed soil and debris. Losses of the San Francisco garter snake may also be difficult to quantify due to a lack of baseline survey data and seasonal/annual fluctuations in their numbers due to environmental or human-caused disturbances. The Service is authorizing take incidental to the proposed action as: (1) the harassment of all San Francisco garter snakes within the action area and (2) the capture and relocation of all San Francisco garter snakes within the 0.63-acre project footprint.

Upon implementation of the following *Reasonable and Prudent Measures*, the incidental take of the California red-legged frog and San Francisco garter snake associated with the proposed project in proportion to the amount and type of take outlined above will become exempt from the prohibitions described under section 9 of the Act. No other forms of take are exempted under this opinion.

Effect of the Take

In the accompanying biological opinion, the Service determined that this level of anticipated take for the California red-legged frog and San Francisco garter snake is not likely to result in jeopardy to the species.

Reasonable and Prudent Measure

The Service has determined that the following reasonable and prudent measure is necessary and appropriate to minimize the effect of the action on the California red-legged frog and San Francisco garter snake. Caltrans will be responsible for the implementation and compliance with this measure:

1. Minimize the adverse effects to the California red-legged frog, San Francisco garter snake and their habitat in the action area by implementing their proposed project, including the conservation measures as described, with the following terms and conditions.

Terms and Conditions

In order to be exempt from the prohibitions of section 9 of the Act, Caltrans must ensure compliance with the following terms and conditions, which implement the reasonable and prudent measure described above. These terms and conditions are nondiscretionary.

1. The following *Terms and Conditions* implement *Reasonable and Prudent Measure* one (1):
 - a. Caltrans shall include a copy of the all relevant permits within the construction bid package of the proposed project. The Resident Engineer or their designee shall be responsible for implementing the *Conservation Measures* and *Terms and Conditions* of this amended biological opinion.
 - b. Information included in a Service-Approved Biological Monitor request shall include, at a minimum: (1) relevant education; (2) relevant training concerning California red-legged frog and San Francisco garter snake identification, survey techniques, handling individuals of different age classes, and handling of different life stages by a permitted biologist or recognized species expert authorized for such activities by the Service; (3) a summary of field experience conducting requested activities (to include project/research information); (4) a summary of biological opinions under which they were authorized to work with the California red-legged frog and San Francisco garter snake and at what level (such as construction monitoring versus handling), this will also include the names and qualifications of persons under which the work was supervised as well as the amount of work experience on the actual project; (5) a list of Federal Recovery Permits [10(a)1(A)] held or under which they are authorized to work with the California red-legged frog and San Francisco garter snake (to include permit number, authorized activities, and name of permit holder); and (6) any relevant professional references with contact information. No project construction will begin until Caltrans has received written Service approval for biologists to conduct specified activities.

- c. Each California red-legged frog encounter shall be treated on a case-by-case basis in coordination with the Service but general guidance is as follows: (1) leave the non-injured animal if it is not in danger or (2) move the animal to a nearby location if it is in danger.

These two options are further described as follows:

- 1) When a California red-legged frog is encountered in the action area the first priority is to stop all activities in the surrounding area that have the potential to result in the harm, harassment, injury, or death of the individual. Then the monitor needs to assess the situation in order to select a course of action that will minimize adverse effects to the individual. Contact the Service once the site is secure. The contacts for this situation are Ryan Olah (ryan_olah@fws.gov) or John Cleckler (john_cleckler@fws.gov). They can also be reached at (916) 414-6623 and (916) 414-6639, respectively. Contact the Service prior to the start of construction to confirm the status of this contact information.

The first priority is to avoid contact with the animal and allow it to move out of the project footprint and hazardous situation on its own to a safe location. The animal should not be picked up and moved because it is not moving fast enough or it is inconvenient for the construction schedule. This guidance only applies to situations where an animal is encountered on the move during conditions that make their upland travel feasible. This does not apply to animals that are uncovered or otherwise exposed or in areas where there is not sufficient adjacent habitat to support the life history of the California red-legged frog should they move outside the construction footprint.

Avoidance is the preferred option if the animal is not moving and is using aquatic habitat or is within some sort of burrow or other refugia. The area should be well marked for avoidance by construction and a Service-Approved Biological Monitor should be assigned to the area when work is taking place nearby.

- 2) The animal should be captured and moved when it is the only option to prevent its death or injury.

If appropriate habitat is located immediately adjacent to the capture location then the preferred option is short distance relocation to that habitat. This must be coordinated with the Service but the general guidance is the frog should not be moved outside of the area it would have traveled on its own. Captured frogs should be released as close to their capture location as feasible possible for their continued safety. Under no circumstances should a frog be relocated to another property without the owner's written permission. It is Caltrans' responsibility to arrange for that permission.

The release must be coordinated with the Service and will depend on where the individual was found and the opportunities for nearby release. In most situations the release location is likely to be into the mouth of a small burrow or other suitable refugia and in certain circumstances pools without non-native predators may be suitable.

Only Service-Approved Biological Monitor for the project can capture California red-legged frogs. Nets or bare hands may be used to capture California red-legged frogs. Soaps, oils, creams, lotions, repellents, or solvents of any sort cannot be used on hands within 2 hours before and during periods when they are capturing and relocating California red-legged frogs. To avoid transferring disease or pathogens between sites during the course of surveys or handling of amphibians, Service-approved biologists must use the following guidance for disinfecting equipment and clothing. These recommendations are adapted from the *Declining Amphibian Population Task Force's Code* (<http://www.open.ac.uk/daptf/>).

- i. All dirt and debris, including mud, snails, plant material (including fruits and seeds), and algae, must be removed from nets, traps, boots, vehicle tires and all other surfaces that have come into contact with water and/or an amphibian. Cleaned items should be rinsed with fresh water before leaving each site.
- ii. Boots, nets, traps, etc., must then be scrubbed with either a 70 percent ethanol solution, a bleach solution (0.5 to 1.0 cup of bleach to 1.0 gallon of water), QUAT 128 (quaternary ammonium, use 1:60 dilution), or a 6 percent sodium hypochlorite 3 solution and rinsed clean with water between sites. Avoid cleaning equipment in the immediate vicinity of a pond or wetland. All traces of the disinfectant must be removed before entering the next aquatic habitat.
- iii. Used cleaning materials (liquids, etc.) must be disposed of safely, and if necessary, taken back to the lab for proper disposal.
- iv. Service-approved biologists must limit the duration of handling and captivity. While in captivity, California red-legged frogs shall be kept in a cool, dark, moist, aerated environment, such as a clean and disinfected bucket or plastic container with a damp sponge. Containers used for holding or transporting should not contain any standing water.

Reporting Requirements

In order to monitor whether the amount or extent of incidental take anticipated from implementation of the project is approached or exceeded, Caltrans shall adhere to the following reporting requirements. Should this anticipated amount or extent of incidental take be exceeded, Caltrans must reinitiate formal consultation as per 50 CFR 402.16.

1. Notification of injured or dead listed species will be made to the Coast-Bay Division Chief of the Endangered Species Program at the Sacramento Fish and Wildlife Office (SFWO) at (916) 414-6623. When an injured or dead individual of the listed species is found, Caltrans shall follow the steps outlined in the following *Disposition of Individuals Taken* section.
2. Sightings of any listed or sensitive animal species should be reported to the CNDDDB (<http://www.dfg.ca.gov/biogeodata/cnddb/>).
3. Construction compliance reports will be addressed to the Coast-Bay Division Chief of the Endangered Species Program at the SFWO.

4. Caltrans shall submit post-construction compliance reports prepared by the Service-approved biologist to the Service within 60 calendar days following completion of each construction season or within 60 calendar days of any break in construction activity lasting more than 60 calendar days. This report shall detail (1) dates that relevant project activities occurred; (2) pertinent information concerning the success of the project in implementing avoidance and minimization measures; (3) an explanation of failure to meet such measures, if any; (4) known project effects on the California red-legged frog and San Francisco garter snake; (5) occurrences of incidental take of any listed species; (6) documentation of employee environmental education; and (7) other pertinent information.

Disposition of Individuals Taken

Injured listed species must be cared for by a licensed veterinarian or other qualified person(s), such as the Service-Approved Biological Monitor. Dead individuals must be sealed in a resealable plastic bag containing a paper with the date and time when the animal was found, the location where it was found, and the name of the person who found it, and the bag containing the specimen frozen in a freezer located in a secure site, until instructions are received from the Service regarding the disposition of the dead specimen. The Service contact person is the Coast-Bay Division Chief of the Endangered Species Program at the SFWO at (916) 414-6623.

CONSERVATION RECOMMENDATIONS

Section 7(a)(1) of the Act directs federal agencies to utilize their authorities to further the purposes of the Act by carrying out conservation programs for the benefit of endangered and threatened species. Conservation recommendations are discretionary agency activities to minimize or avoid adverse effects of a proposed action on listed species or critical habitat, to help implement recovery plans, or to develop information. The Service recommends the following actions:

1. Caltrans District 4 should work with the Service to develop a conservation strategy that would identify the current safe passage potential along Bay Area highways and the areas where safe passage for wildlife could be enhanced or established.
2. Caltrans should assist the Service in implementing recovery actions identified in the *Recovery Plan for the California Red-legged Frog* (Service 2002) and *Recovery Plan for the San Francisco Garter Snake* (Service 1985).
3. Caltrans should consider participating in the planning for a regional habitat conservation plan for the California red-legged frog, San Francisco garter snake, other listed species, and at-risk species.
4. Caltrans should consider establishing functioning preservation and creation conservation banking systems to further the conservation of the California red-legged frog and San Francisco garter snake. Such banking systems also could be utilized for other required mitigation (i.e., seasonal wetlands, riparian habitats, etc.) where appropriate. Efforts should be made to preserve habitat along roadways in association with wildlife crossings.

In order for the Service to be kept informed of actions minimizing or avoiding adverse effects or benefiting listed species or their habitats, the Service requests notification of the implementation of any conservation recommendations.

REINITIATION--CLOSING STATEMENT

This concludes reinitiation of formal consultation on the SR 1 Elliot Creek and Finney Creek Storm Damage Project. As provided in 50 CFR §402.16, subsequent reinitiation of formal consultation is required and shall be requested by the federal agency or by the Service where discretionary federal agency involvement or control over the action has been retained or is authorized by law and: (a) if the amount or extent of taking specified in the incidental take statement is exceeded; (b) if new information reveals effects of the action that may affect listed species or critical habitat in a manner or to an extent not previously considered; (c) if the identified action is subsequently modified in a manner that causes an effect to the listed species or critical habitat that was not considered in this amended biological opinion; or (d) if a new species is listed or critical habitat designated that may be affected by the identified action.

If you have questions concerning this reinitiation or implementation of its measures, please contact John Cleckler, Caltrans Liaison, john_cleckler@fws.gov, (916) 414-6639 or Ryan Olah, Coast-Bay Division Chief, ryan_olah@fws.gov, (916) 414-6623, at the letterhead address, by telephone, or by e-mail.

Sincerely,



Jennifer M. Norris, Ph.D.
Field Supervisor

cc:

Robert Stanley, California Department of Fish and Wildlife, Napa, California
Gregory Pera and Elizabeth Leyvas, Caltrans District 4, Oakland, California

Literature Cited

- Ashley, E. P., and J. E. Robinson. 1996. Road mortality of amphibians, reptiles and other wildlife on the Long Point Causeway, Lake Erie, Ontario. *Canadian Field Naturalist* 110:403–412.
- Barry, S. 1992. Letter to Marvin L. Plenert, Regional Director, U.S. Fish and Wildlife Service, Portland, Oregon, regarding proposed listing.
- Bosch, J., I. Martinez-Solano, and M. Garcíaparis. 2001. Evidence of a chytrid fungus infection involved in the decline of the common midwife toad (*Alytes obstetricans*) in protected areas of central Spain. *Biological Conservation* 97:331–337.
- Bulger, J. B., N. J. Scott, Jr., and R. B. Seymour. 2003. Terrestrial activity and conservation of adult California red-legged frogs *Rana aurora draytonii* in coastal forests and grasslands. *Biological Conservation* 110:85–95.
- Bury, R. B., and J. A. Whelan. 1984. Ecology and Management of the Bullfrog. Fish and Wildlife Service/Resource Publication 155. 23 pages.
- Buza, L., A. Young, and P. Thrall. 2000. Genetic erosion, inbreeding and reduced fitness in fragmented populations of the endangered tetraploid pea *Swainsona recta*. *Biological Conservation* 93:177–186.
- California Department of Fish and Wildlife (CDFW). 2017. California Natural Diversity Data Base (CNDDB) RAREFIND. Natural Heritage Division, Sacramento, California.
- California Department of Transportation (Caltrans). 2007. Biological assessment for the restoration of the hydraulic capacity of the Cowan Storm Drain Canal within the U.S. Highway 101/Millbrae Avenue Interchange. EA 3A0400. December 2007. Caltrans District 4, Oakland, California.
- California State Parks. 2008. Ano Nuevo State Park Final General Plan and Environmental Impact Report. October 31, 2008. Sacramento, California. 423 pages.
- _____. 2013. Big Basin Redwoods State Park Final General Plan and Environmental Impact Report. May 17, 2013. Sacramento, California. 444 pages.
- Carr, L. W., and L. Fahrig. 2001. Effect of road traffic on two amphibian species of differing vagility. *Conservation Biology* 15:1,071–1,078.
- Cooke, A. S. 1995. Road mortality of common toads (*Bufo bufo*) near a breeding site, 1974–1994. *Amphibia-Reptilia* 16:87–90.
- Davidson, E. W., M. Parris, J. Collins, J. Longcore, A. P. Pessier, and J. Brunner. 2003. Pathogenicity and transmission of Chytridiomycosis in tiger salamanders (*Ambystoma tigrinum*). *Copeia* 2003(3):601–607.
- Drews, C. 1995. Road kills of animals by public traffic in Mikumi National Park, Tanzania, with notes on baboon mortality. *African Journal of Ecology* 33:89–100.

- Emlen, S. T. 1977. "Double clutching" and its possible significance in the bullfrog. *Copeia* 1977(4):749–751.
- Fellers, G. 2005. *Rana draytonii* Baird and Girard, 1852b California red-legged frog. Pages 552–554 in M. Lannoo (editor). Amphibian declines the conservation status of United States species. University of California Press. Berkeley, California.
- Fisher, R. N., and H. B. Schaffer. 1996. The Decline of Amphibians in California's Great Central Valley. *Conservation Biology* 10(5):1,387–1,397.
- Forman, T. T., and R. D. Deblinger. 1998. The ecological road-effect zone for transportation planning. and a Massachusetts highway example. Pages 78–96 in G. L. Evink, P. Garrett, D. Zeigler, and J. Berry (editors). Proceedings of the international conference on wildlife ecology and transportation. Publication FL-ER-69-98. Florida Department of Transportation, Tallahassee.
- _____. 2000. The Ecological Road-Effect Zone of a Massachusetts (U.S.A) Suburban Highway. *Conservation Biology* 14:36–46.
- Garner, T. W. J., S. Walker, J. Bosch, A. D. Hyatt, A. A. Cunningham, and M. C. Fisher. 2005. Chytrid fungus in Europe. *Emerging Infectious Diseases* 11:1,639–1,641.
- Hansen, L. 1982. Trafikdræbte dyr i Danmark (Road kills in Denmark, in Danish). *Dansk Ornitologisk Forenings Tidsskrift* 76:97–110.
- Hayes, M. P., and M. R. Jennings. 1988. Habitat correlates of distribution of the California red-legged frog (*Rana aurora draytonii*) and the foothill yellow-legged frog (*Rana boylei*): implications for management. Pages 144–158 in R. Sarzo, K. E. Severson, and D. R. Patton (technical coordinators). Proceedings of the symposium on the management of amphibians, reptiles, and small mammals in North America. United States Department of Agriculture, Forest Service, Rocky Mountain Range and Experiment Station, Fort Collins, Colorado. General Technical Report (RM-166):1–458.
- Hayes, M. P., and D. M. Krempeles. 1986. Vocal sac variation among frogs of the genus *Rana* from western North America. *Copeia* 1986(4):927–936.
- Hayes, M. P., and M. M. Miyamoto. 1984. Biochemical, behavioral and body size differences between *Rana aurora aurora* and *R. a. draytonii*. *Copeia* 1984(4):1,018–1,022.
- Hayes, M. P., and M. R. Tennant. 1985. Diet and feeding behavior of the California red-legged frog, *Rana aurora draytonii* (Ranidae). *Southwestern Naturalist* 30(4):601–605.
- Hels, T., and E. Buchwald. 2001. The effect of road kills on amphibian populations. *Biological Conservation* 99:331–340.
- Hunt, L. 1993. Letter to Marvin L. Plenert, Regional Director, U.S. Fish and Wildlife Service, Portland, Oregon, regarding proposed listing.
- Jennings, M. R. 1993. Letter to Peter C. Sorensen, U.S. Fish and Wildlife Service, Sacramento, California.

- Jennings, M. R., and M. P. Hayes. 1985. Pre-1900 overharvest of California red-legged frogs (*Rana aurora draytonii*): The inducement for bullfrog (*Rana catesbeiana*) introduction. *Herpetological Review* 31(1):94–103.
- _____. 1990. Final report of the status of the California red-legged frog (*Rana aurora draytonii*) in the Pescadero Marsh Natural Preserve. Final report prepared for the California Department of Parks and Recreation, Sacramento, California, through Agreement (4-823-9018). Department of Herpetology, California Academy of Sciences, Golden Gate Park, San Francisco, California. 30 pages.
- _____. 1994. Amphibian and reptile species of special concern in California. California Department of Fish and Game, Rancho Cordova, California. 255 pages.
- Jennings, M. R., M. P. Hayes, and D. C. Holland. 1992. A petition to the U.S. Fish and Wildlife Service to place the California red-legged frog (*Rana aurora draytonii*) and the western pond turtle (*Clemmys marmorata*) on the list of endangered and threatened wildlife and plants. 21 pages.
- Kupferberg, S. J. 1996a. Hydrologic and Geomorphic Factors Affecting Conservation of a River-Breeding Frog (*Rana boylei*). *Ecological applications* 6:1,322–1,344.
- _____. 1996b. The Ecology of Native Tadpoles (*Rana boylei* and *Hyla regilla*) and the Impacts of Invading Bullfrogs (*Rana catesbeiana*) in a Northern California River. PhD dissertation. University of California, Berkeley, California.
- _____. 1997. Bullfrog (*Rana catesbeiana*) Invasion of a California River: The Role of Larval Competition. *Ecology* 78(6):1,736–1,751.
- Lips, K. R., D. E. Green, and R. Papendick. 2003. Chytridiomycosis in wild frogs from southern Costa Rica. *Journal of Herpetology* 37(1):215–218.
- MacArthur, R. A., R. H. Johnston, and V. Geist. 1979. Factors in influencing heart rate in free-ranging bighorn sheep: a physiological approach to the study of wildlife harassment. *Canadian Journal of Zoology* 57:2,010–2,021.
- Mallick, S. A., G. J. Hocking, and M. M. Driessen. 1998. Road-kills of the eastern barred bandicoot (*Perameles gunnii*) in Tasmania: an index of abundance. *Wildlife Research* 25:139–145.
- Moyle, P. B. 1976. Fish Introductions in California: History and Impact on Native Fishes. *Biological Conservation* 9(1):101–118.
- Munguira, M. L., and J. A. Thomas. 1992. Use of road verges by butterfly and moth populations, and the effect of roads on adult dispersal and mortality. *Journal of Applied Ecology* 29:316–329.
- Rosen, P. C., and C. H. Lowe. 1994. Highway mortality of snakes in the Sonoran desert of southern Arizona. *Biological Conservation* 68:143–148.
- Stebbins, R. C. 2003. A field guide to western reptiles and amphibians. Houghton Mifflin Company, Boston, Massachusetts. 533 pages.

- Storer, T. I. 1925. A synopsis of the amphibia of California. University of California Publications in Zoology 27:1–342.
- _____. 1933. Frogs and their commercial use. California Department of Fish and Game 19(3):203–213.
- Stuart, J. M., M. L. Watson, T. L. Brown, and C. Eustice. 2001. Plastic netting: an entanglement hazard to snakes and other wildlife. Herpetological Review 32(3):162–164.
- Tatarian, P. J. 2008. Movement Patterns of California red-legged frogs (*Rana draytonii*) in an Inland California Environment. Herpetological Conservation and Biology 3(2):155–169. November.
- Trombulak, S. C., and C. A. Frissell. 2000. The ecological effects of roads on terrestrial and aquatic communities: a review. Conservation Biology 14:18–30.
- Twedt, B. 1993. A comparative ecology of *Rana aurora* Baird and Girard and *Rana catesbeiana* Shaw at Freshwater Lagoon, Humboldt County, California. Unpublished. Master of Science thesis. Humboldt State University, Arcata, California. 53 pages plus appendix.
- U. S. Fish and Wildlife Service (Service). 1985. Recovery Plan for the San Francisco Garter Snake (*Thamnophis sirtalis tetrataenia*). U.S. Fish and Wildlife Service, Portland, Oregon. 77 pages.
- _____. 1996. Endangered and threatened wildlife and plants; determination of threatened status for the California Red-Legged Frog. **Federal Register** 61:25813-25833.
- _____. 2002. Recovery plan for the California red-legged frog (*Rana aurora draytonii*). Portland, Oregon. 173 pages.
- _____. 2005. Revised Guidance on Site Assessments and Field Surveys for the California Red-legged Frog. August 2005. Portland, Oregon. 26 pages.
- _____. 2006a. Endangered and threatened wildlife and plants; designation of critical habitat for the California red-legged frog (*Rana aurora draytonii*), and special rule exemption associated with final listing for existing routine ranching activities; final rule. **Federal Register** 71(71):19244-19346.
- _____. 2006b. San Francisco Garter Snake (*Thamnophis sirtalis tetrataenia*) 5-Year Review: Summary and Evaluation. September 2006. Sacramento, California. 46 pages.
- _____. 2010. Endangered and threatened wildlife and plants; revised designation of critical habitat for California red-legged frog; final rule. Federal Register 71:190815–12959.
- Van der Zande, A. N., W. J. ter Keurs, and W. J. Van der Weijden. 1980. The impact of roads on the densities of four bird species in an open field habitat - evidence of a long-distance effect. Biological Conservation 18:299–321.
- Van Gelder, J. J. 1973. A quantitative approach to the mortality resulting from traffic in a population of *Bufo bufo* L. Oecologia 13:93–95.
- Vos, C. C., and J. P. Chardon. 1998. Effects of habitat fragmentation and road density on the distribution pattern of the moor frog, *Rana arvalis*. Journal of Applied Ecology 35:44–56.

Weldon, C., du Preez, L. H., Muller, R., Hyatt, A. D., and Speare, R. 2004. Origin of the amphibian chytrid fungus. *Emerging Infectious Diseases* 10:2100-2105.

Wright, A. H., and A. A. Wright. 1949. *Handbook of frogs and toads of the United States and Canada*. Comstock Publishing Company, Inc., Ithaca, New York. 640 pages.

Personal Communication

Gaber, Christine. 2008. Senior Wildlife Biologist, Pacific Gas and Electric, Walnut Creek, California. Personal communication with Chris Nagano, U.S. Fish and Wildlife Service, Sacramento Fish and Wildlife Office, on October 22, 2008.

Kobernus, Patrick. 2008. Wildlife Biologist, Coast Ridge Ecology, San Francisco, California. Personal communication with Michelle Havens, U.S. Fish and Wildlife Service, Sacramento Fish and Wildlife Office, on October 16, 2008.



County of San Mateo - Planning and Building Department

ATTACHMENT H

CALIFORNIA COASTAL COMMISSION

NORTH CENTRAL COAST DISTRICT OFFICE
45 FREMONT STREET, SUITE 2000
SAN FRANCISCO, CA 94105
PHONE: (415) 904-5260
FAX: (415) 904-5400
WEB: WWW.COASTAL.CA.GOV



April 20, 2018

Mr. Mike Schaller
San Mateo County
Planning and Building Department
455 County Center, 2nd Floor
Mail Drop PLN122
Redwood City, CA 94063

RE: San Mateo County PLN2018-00051 (Caltrans), Elliot Creek, Pescadero

Dear Mr. Schaller,

Thank you for forwarding the Planning Permit Application Referral for PLN2018-00051, dated April 6, 2018, which we received on April 11, 2018 for Commission staff review. The applicant is seeking a Coastal Development Permit for the repair of two slip-outs caused by storm water runoff at two locations on State Route 1 (Highway 1). Location 1 (post mile 0.3) is adjacent to the southbound lane in the vicinity of Elliot Creek and Location 2 is adjacent to the northbound lane near Finney Creek. The proposed project includes the repair of a section of the eroding embankment and a section of the roadway adjacent to the slip-out. A non-functioning drainage system at Location 2 is causing excessive surface water ponding will be reconstructed and slope erosion on the east side of the roadway will be repaired.

Biological Resources

The project referral indicates that the proposed project will result in direct permanent impacts to California red-legged frog and San Francisco garter snake habitat in the form of loss of upland habitat suitable for these two species. The referral also states probable impacts could include temporary loss of habitat, harassment for the length of the project, injury, and death of individuals.

Elliot and Finney creeks are located within the proposed project area. The applicant's Biology Impact Form included with the project referral does not state whether or not these creeks are perennial or intermittent streams. The report, however, does indicate that "semi-riparian" habitat occurs in the vicinity of the project. Perennial and intermittent streams and their tributaries are defined by Local Coastal Program (LCP) Policy 7.1 as sensitive habitat; and designated as such under LCP Policy 7.2. Sensitive habitat areas include riparian corridors, wetlands, and other areas that contain or support special status species. The biological form states that wetland field surveys were performed in January and July 2017. The form, however, does not provide any additional information regarding survey results and the proposed project's potential impact to wetlands or the adjacent streams. We recommend that the County require the applicant provide information regarding potential wetland and stream impacts. The County analysis should

consider these potential impacts and require that the applicant avoid, minimize, and mitigate potential wetland impacts. The County analysis should review the proposed project's consistency with LCP Policy 7.14 (Definition of Wetlands), 7.16 (Permitted Uses in Wetlands), and 7.17 (Performance Standards), if applicable.

The removal of vegetation will result in loss of potential habitat for CRLF and SFGS in the form of direct permanent loss (0.027 acre) of upland habitat. There will also be temporary direct effects to ground cover. The applicant identifies indirect effects that include a "lack of natural ground cover" stating it is expected to be short. The applicant's biological impact form additionally states that the vegetation is expected to re-grow and sufficiently cover the disturbed area within one year. A rock dissipater pad will be placed at Finney Creek and the applicant states that no mitigation is anticipated for this proposed work. Upland habitat for CRLF and SFGS does have value in support of these two species. We recommend that all permanent loss of suitable upland habitat for CRLF and SFGS should be mitigated at a minimum ratio of 2:1. The County should also require that the applicant provide mitigation for all temporary impacts associated with the construction activities for the project.

LCP Policy 7.3 prohibits any development or land use that would have a significant, adverse, impact on sensitive habitat areas. This policy also requires that development be sited and designed to prevent impacts that could significantly degrade sensitive habitat. The County should evaluate whether or not the proposed project is consistent with the LCP policies for the protection of sensitive habitats.

Visual Resources and Water Quality

The proposed project site is located within the Cabrillo Highway State Scenic Corridor. The applicant's scenic resource evaluation states that concrete that is visible along the slopes shall be stained to blend with the coastal landscape. The County should require the applicant to provide specific information regarding the material proposed to be used for staining the concrete including what will be used, how it will be applied and maintained over time, what Best Management Practices and measures will be utilized to effectively prevent adverse impacts to the natural environment, including the adjacent creeks and coastal water.

Agriculture

The proposed project site is located within an area zoned as Planned Agriculture (PAD). There are agricultural parcels in the immediate vicinity of the location near Finney Creek. The County analysis should include a discussion of the proposed project's consistency with the LCP policies for the PAD.

Coastal Access

The proposed project site is in the vicinity of the Año Nuevo State Natural Preserve and to the south of Pigeon Point Lighthouse, which are destination points for travelers along Highway 1. LCP Public Works Policies 2.42, 2.43, 2.44, 2.47, and 2.51 regulate road capacity, desired level of service, and protect road capacity for visitors in coastal areas. The primary road access to the coast in San Mateo County is via Highway 1. Studies show that the current volume of traffic on

Mike Schaller, San Mateo County
PLN2018-00051
April 20, 2018
Page 3

Highway 1 exceeds its capacity and that even with substantial investment in transit and highway improvements, congestion will only get worse in the future. This proposed project could temporarily generate additional traffic in the area during construction. The County analysis should evaluate potential traffic impacts during construction and the effectiveness of the applicant's plan for managing traffic.

Please feel free to contact me if you have questions regarding our comments. You can reach me by telephone at 415-904-5260; or in writing at the address listed in the letter head or via e-mail at renee.ananda@coastal.ca.gov.

Sincerely,

A handwritten signature in cursive script that reads "Renee T. Ananda". The signature is written in black ink and is positioned above the typed name.

Renée T. Ananda, Coastal Program Analyst
North Central Coast District



County of San Mateo - Planning and Building Department

ATTACHMENT I

M e m o r a n d u m

*Making Conservation
a California Way of Life*

To: RACHEL COTRONEO
CH2M HILL

Date: June 20, 2017

File: SM-04-0J210
0413000444
*Elliot Creek Storm
Damage*

From: ELIZABETH LEYVAS
Environmental Planner (Natural Sciences)
Office of Biological Sciences and Permits
D4 Oakland Office

Subject: WETLAND DELINEATION AND RARE PLANT MEMO

Project Description:

The California Department of Transportation (Caltrans) proposes to stabilize a slope with rock slope protection (RSP), add two new drainage inlets and dikes, and correct a sag point in the road. This will occur on State Route 1 (SR 1) at Post Mile 0.3 over Elliot Creek in San Mateo County. The purpose of the project is to correct existing storm damage and to prevent future erosion. This project is needed to enhance driver safety and to prevent future erosion. Major project components include: 1) placing 1500 square feet (0.048 acres) of rock slope protection (RSP) on the bluff west of the project site; 2) installing two drainage inlets and dikes along the southbound direction; 3) correcting a sag point in the road by digging down to a maximum of five feet across both lanes of traffic; 4) repairing/resurfacing the existing roadway as needed; 5) place soil over RSP two feet high (3,000 cubic feet); and 6) revegetate disturbed soil.

Rock slope protection will be installed to repair erosion adjacent to the roadway and will permanently impact 0.048 acres on the southbound side of SR 1. Staging encompasses approximately 0.09 acres of soil and will be located about 250 feet south of this area on the southbound side of SR 1. All work will be conducted during the day, over a period of 40 working days (eight weeks). A one-lane road closure will be used to accommodate traffic flow during construction.

Biological Setting:

The project area lies on a bluff within the fog belt of the California coast, and is subject to storm water runoff from SR 1. It is about 20 feet above a culverted creek (Elliot Creek) and is not near

the water table. The nearest wetland aside from this culverted creek is 0.5 miles north. This area is characterized as coastal bluff scrub and Monterey pine forest. Primary land use is for California state parks and agriculture.

Rare Plant and Wetland Delineation:

A field visit was conducted on April 27th 2017, at which time conditions were clear and temperatures were in the mid 60's. Caltrans biologists Elizabeth Leyvas and Mita Nagarkar surveyed areas within the project footprint including the staging area, the shoulders of the road, and the slope (approximately 0.25 acres total). The primary purpose of the survey was to assess the potential for rare plants to occur in the project area, and to determine presence of jurisdictional wetlands. Vegetation was characterized by coastal bluff scrub, non-native ice plants, Monterey pine, and dense growth of poison oak and non-native grasses. No rare plants were seen during the site visit. The California Department of Fish and Wildlife (CDFW) database searches in the California Natural Diversity Database (CNDDDB), as well as records from the Calflora database are consistent with our survey. Rare plants are unlikely to appear onsite.

It was determined that no hydrophytic vegetation, hydric soils, or wetland hydrology was present within the project footprint and that Elliot Creek was the only jurisdictional water within the biological study area (BSA). Soil pits were not dug, due to the lack of hydrophytic vegetation. The USDA Web Soil Survey shows no hydric rating for soils present in this location. The vegetation onsite was consistent with coastal bluff scrub, and the dominant tree type was Monterey pine. The California Coastal Commission [California Code of Regulations Title 14 (14 CCR)] only requires a one parameter standard for wetlands. Based on our site visit, we assume no U.S. Army Corps of Engineers (ACOE) or CCC jurisdictional wetlands are present within the BSA. However, Elliot Creek within the BSA is jurisdictional to both agencies. This jurisdictional section of Elliot Creek is culverted and will be avoided; all work will be done above the bank of Elliot Creek.

Conclusions:

A wetland delineation was not performed due to the lack of evidence of qualifying characteristics. The project site is approximately 0.25 acres that encompasses staging, RSP, and areas along the shoulder, is not a wetland. Rare plants are unlikely to appear onsite.

References:

California Natural Diversity Database (CNDDDB) Rare Find 5. 2017. California Department of Fish and Wildlife. 2016-2017. Available:

<https://www.wildlife.ca.gov/Data/CNDDDB/Maps-and-Data>.

Calflora: Information on California plants for education, research and conservation. [web application]. 2017. Berkeley, California: The Calflora Database [a non-profit organization]. Available: <http://www.calflora.org/> (Accessed: April 26, 2017).

Plant List

Family	Scientific Name	Common Name	Status
Aizoaceae	<i>Carpobrotus edulis</i>	iceplant	invasive
Anacardiaceae	<i>Toxicodendron diversilobum</i>	poison oak	native
Apiaceae	<i>Conium maculatum</i>	poison hemlock	invasive
Asteraceae	<i>Artemisia californica</i>	California sagebrush	native
Asteraceae	<i>Baccharis pilularis</i>	coyote brush,	native
Asteraceae	<i>Carduus pycnocephalus</i>	Italian thistle	invasive
Asteraceae	<i>Cirsium vulgare</i>	bull thistle	invasive
Asteraceae	<i>Helminthotheca echioides</i>	bristly ox-tongue	invasive
Asteraceae	<i>Matricaria discoidea</i>	pineapple weed	native
Brassicaceae	<i>Raphanus sativus</i>	wild radish	invasive
Crassulaceae	<i>Dudeya farinose</i>	sea lettuce	native
Cucurbitaceae	<i>Marah fabacea</i>	California man-root	native
Cupressaceae	<i>Cupressus macrocarpa</i>	Monterey cypress	non-native
Fabaceae	<i>Vicia sativa ssp. sativa</i>	garden vetch	non-native
Fagaceae	<i>Notholithocarpus densiflorus</i>	tanoak	native
Geraniaceae	<i>Geranium dissectum</i>	cut leaved geranium	invasive
Geraniaceae	<i>Geranium molle</i>	crane's bill geranium	non-native
Lysimachia	<i>Lysimachia arvensis</i>	scarlet pimpernel	non-native
Oxalidaceae	<i>Oxalis pes-caprae</i>	Bermuda buttercup	invasive
Papaveraceae	<i>Eschscholzia californica</i>	California poppy	native
Pinus	<i>Pinus attenuata</i>	knobcone pine	native
Pinus	<i>Pinus radiata</i>	Monterey pine	invasive/1B.1
Plantaginaceae	<i>Plantago lanceolate</i>	English plantain	invasive
Poaceae	<i>Avena fatua</i>	wild oat	invasive

Poaceae	<i>Briza maxima</i>	rattlesnake grass	invasive
Poaceae	<i>Bromus diandrus</i>	ripgut brome	invasive
Poaceae	<i>Holcus lanatus</i>	velvet grass	invasive
Polygonaceae	<i>Rumex sp.</i>	dock	
Rosaceae	<i>Heteromeles arbutifolia</i>	Christmas berry/ Toyon	native
Rosaceae	<i>Rubus ursinus</i>	California blackberry	native

M e m o r a n d u m

*Making Conservation
a California Way of Life*

To: Gregory Pera
Caltrans

Date: February 8, 2018

File: SM-04-0J210
0413000444

*Elliot Creek and Finney
Creek Storm Damage
Project*

From: ELIZABETH LEYVAS
Environmental Planner (Natural Sciences)
Office of Biological Sciences and Permits
D4 Oakland Office

Subject: WETLAND DELINEATION AND RARE PLANT MEMO

Project Description:

This MEMO is in addition to the previous MEMO on project EA 04-0J210 Elliot Creek Storm Damage, now Elliot Creek and Finney Creek Storm Damage Project (Project). The California Department of Transportation (Caltrans) proposes to repair a section of the roadway on State Route 1 (SR 1) at Post Mile 0.6 at Finney Creek in San Mateo County, California. The purpose of the Project is to correct existing storm damage. The Project is needed to enhance driver safety and to prevent future erosion. Major Project components are as follows:

- 1) Cap the entrance of the existing down drain;
- 2) Install three drain inlets with 18" APC connecting the inlets in the northbound direction;
- 3) Re-construct the AC dike;
- 4) Install a down drain and rock pad at the discharge point; and
- 5) Revegetate disturbed soil.

A rock pad measuring 6 feet by 6 feet will be installed to dissipate the discharge of water from the three proposed drainage inlets. The rock pad will be about 10 feet east of northbound SR 1 and will permanently impact 0.001 acres of land. Staging and other minor ground disturbance encompass approximately 0.06 acres of soil. Staging (0.03 acres) will be located 30 feet north of the work area on a dirt and grassy area on the shoulder of northbound SR 1. All work at Finney Creek will be conducted during the day, over a period of 5 working days (1 week) and will stay

within the overall Project timeline of 8 weeks. A one-lane road closure will be used to accommodate traffic flow during construction.

Biological Setting:

The project area lies on a bluff within the fog belt of the California coast, and is subject to storm water runoff from SR 1. It is about 20 feet above a culverted creek (Finney Creek) and is not near the water table. The nearest wetland aside from this culverted creek is 0.06 miles west (estuarine and marine wetland/Pacific Ocean) and 0.20 miles north (freshwater emergent wetland and freshwater pond). This area is characterized as coastal bluff scrub and Monterey pine forest. Primary land use is for California state parks and agriculture.

Rare Plant and Wetland Delineation:

A field visit was conducted on November 1st, 2017, at which time conditions were clear and temperatures were in the mid 60's. Caltrans biologist Elizabeth Leyvas surveyed areas within the project footprint including the staging area, the shoulders of the road, and the proposed rock pad area (approximately 0.25 acres total). The primary purpose of the survey was to assess the potential for rare plants to occur in the project area, and to determine presence of jurisdictional wetlands. Vegetation was characterized by coastal bluff scrub, non-native grasses, Monterey pine, and dense growth of poison oak (*Toxicodendron diversilobum*), California blackberry (*Rubus ursinus*), and non-native forbes. No rare plants were seen during the site visit. The California Department of Fish and Wildlife (CDFW) database searches in the California Natural Diversity Database (CNDDDB), as well as records from the Calflora database are consistent with our survey. Soils data from the Web Soils Survey of the United States Department of Agriculture (USDA) were cross-referenced with rare plant habitat and came up consistent with our finding for this area. Rare plants are unlikely to appear onsite.

It was determined that no hydrophytic vegetation, hydric soils, or wetland hydrology was present within the project footprint and that Finney Creek was the only jurisdictional water within the biological study area (BSA). Soil pits were not dug, due to the lack of hydrophytic vegetation. The USDA Web Soil Survey shows no hydric rating for soils present in the work area. The vegetation onsite was consistent with coastal bluff scrub, and the dominant tree type was Monterey pine. The California Coastal Commission [California Code of Regulations Title 14 (14 CCR)] only requires a one parameter standard for wetlands. Based on our site visit, we assume no U.S. Army Corps of Engineers (ACOE) or CCC jurisdictional wetlands are present within the BSA. However, Finney Creek within the BSA is jurisdictional to both agencies. This jurisdictional section of Finney Creek is outside of the work area and will be avoided; all work will be done adjacent to the bank of Finney Creek.

Conclusions:

A wetland delineation was not performed due to the lack of evidence of qualifying characteristics. The project site is approximately 0.10 acres that encompasses staging, rock pad, and areas along the shoulder. It is not a wetland. Rare plants are unlikely to appear onsite.

References:

- California Natural Diversity Database (CNDDDB) Rare Find 5. 2017. California Department of Fish and Wildlife. 2016-2017. Available: <https://www.wildlife.ca.gov/Data/CNDDDB/Maps-and-Data>.
- Calflora: Information on California plants for education, research and conservation. [web application]. 2017. Berkeley, California: The Calflora Database [a non-profit organization]. Available: <http://www.calflora.org/> (Accessed: April 26, 2017).
- Web Soil Survey: Natural Resources Conservation Service. [Web application].2017. United States Department of Agriculture (USDA). Available: <https://websoilsurvey.sc.egov.usda.gov/App/HomePage.htm> (accessed November 6, 2017).

Plant List Finney Creek

Family	Scientific Name	Common Name	Status
Anacardiaceae	<i>Toxicodendron diversilobum</i>	poison oak	native
Asteraceae	<i>Artemisia californica</i>	California sagebrush	native
Asteraceae	<i>Baccharis pilularis</i>	coyote brush,	native
Asteraceae	<i>Carduus pycnocephalus</i>	Italian thistle	invasive
Asteraceae	<i>Helminthotheca echioides</i>	bristly ox-tongue	invasive
Asteraceae	<i>Matricaria discoidea</i>	pineapple weed	native
Brassicaceae	<i>Raphanus sativus</i>	wild radish	invasive
Cupressaceae	<i>Cupressus macrocarpa</i>	Monterey cypress	non-native
Fabaceae	<i>Vicia sativa ssp. sativa</i>	garden vetch	non-native
Fagaceae	<i>Notholithocarpus densiflorus</i>	tanoak	native
Geraniaceae	<i>Geranium dissectum</i>	cut leaved geranium	invasive
Geraniaceae	<i>Geranium molle</i>	crane's bill geranium	non-native
Pinus	<i>Pinus attenuata</i>	knobcone pine	native
Pinus	<i>Pinus radiata</i>	Monterey pine	invasive/1B.1
Plantaginaceae	<i>Plantago lanceolata</i>	English plantain	invasive
Poaceae	<i>Avena fatua</i>	wild oat	invasive
Poaceae	<i>Briza minor</i>	little quaking grass	Non-native
Rosacea	<i>Heteromeles arbutifolia</i>	toyon	native
Rosacea	<i>Rubus ursinus</i>	California blackberry	native