

**COUNTY OF SAN MATEO  
PLANNING AND BUILDING DEPARTMENT**

**DATE:** December 20, 2018

**TO:** Zoning Hearing Officer

**FROM:** Planning Staff

**SUBJECT:** Consideration of three Use Permits, pursuant to Section 6500 of the San Mateo County Zoning Regulations, to install new wireless telecommunication facilities on existing joint utility poles located in the public right-of-way in front of: (1) 2866 Hillside Drive, in the unincorporated Burlingame Hills (BGH) area of San Mateo County (2) 138 Valdeflores Drive, in the unincorporated Burlingame Hills area of San Mateo County and, (3) Adjacent to 176-798 Cañada Road located in the public Right-of-Way in the unincorporated Woodside (WDS) area of San Mateo County.

County File Numbers:

Item 1	PLN 2018-00090
Item 2	PLN 2018-00089
Item 3	PLN 2018-00092

**PROPOSAL**

The applicant proposes to install new wireless telecommunication facilities on existing joint utility poles located in the public right-of-way in front of: (1) 2866 Hillside Drive, (2) 138 Valdeflores Drive in unincorporated Burlingame Hills (Items 1 and 2) and Unincorporated Woodside (Item 3) areas. The new facilities will consist of a 7-foot pole extension, one 4-foot tall cylindrical antenna, and ancillary pole mounted equipment. The new facilities will have an effective height of between 49'-6" to 59.6" above grade where the maximum height allowed in each zoning district ranges from 28 to 36 feet above grade. No grading or tree removal activities are proposed.

**RECOMMENDATION**

That the Zoning Hearing Officer approve the Use Permits, County File Numbers, as listed below, by making the required findings and adopting the conditions of approval listed in Attachment A:

Item 1	PLN 2018-00090	2866 Hillside Drive, BGH
Item 2	PLN 2018-00089	138 Valdeflores Drive, BGH
Item 3	PLN 2018-00092	176-798 Cañada Road, WDS

## **BACKGROUND**

Report Prepared By: Tiare Peña, Project Planner, 650/363-1850

Applicant: Verizon Wireless c/o Modus

Land Owner: San Mateo County Department of Public Works

Pole Owner: Pacific Gas and Electric

Property Details for the Proposed Use Permits

<b>Item 1 – County File Number: PLN 2018-00090</b>	
Location	Public Right-of-Way in front of 2866 Hillside Drive, BGH
APN	Public Right-of-Way adjacent to 027-093-250
Existing Zoning	R-1/S-9 (Single-Family Residential/10,000 sq. ft. minimum lot size)
General Plan Designation	Medium Low Density Residential Urban
Flood Zone	Zone X (area of minimal flood risk): FEMA Panel No. 06081 C0134E; Effective October 16, 2012
Sphere-of-Influence	City of Burlingame

<b>Item 2 – County File Number: PLN 2018-00089</b>	
Location	Public Right-of-Way in front of 138 Valdeflores Drive
APN	Public Right-of-Way adjacent to 027-063-090
Existing Zoning	R-1/S-9 (Single-Family Residential/10,000 sq. ft. minimum lot size)
General Plan Designation	Medium Low Density Residential Urban
Flood Zone	Zone X (area of minimal flood risk): FEMA Panel No. 06081 C0134E; Effective October 16, 2012
Sphere-of-Influence	City of Burlingame

<b>Item 3 – County File Number: PLN 2018-00092</b>	
Location	Public Right-of-Way in front of 176-798 Cañada Road
APN	Public Right-of-Way adjacent to 093-180-030
Existing Zoning	R-1/S-7 (Single-Family Residential/5,000 sq. ft. minimum lot size)
General Plan Designation	Open Space Rural
Flood Zone	Zone X (area of minimal flood risk): FEMA Panel No 06081 C0285E; Effective October 16, 2012
Sphere-of-Influence	Town of Woodside

Environmental Evaluation: All projects are categorically exempt under the provisions of Class 3, Section 15303, of the California Environmental Quality Act (CEQA) Guidelines for the construction of a new small structure and installation of small new equipment and a facility in a small structure.

Setting: Two of the proposed project sites are located on existing utility poles in the public Right-of-Way (ROW) in the unincorporated Burlingame Hills area of San Mateo County. One of the proposed project sites is located on existing utility poles in the unincorporated Woodside area of San Mateo County.

Chronology:

<u>Date</u>	<u>Action</u>
March 26, 2018	- Use Permit applications submitted
May 25, 2018	- Project deemed complete
December 20, 2018	- Zoning Hearing Officer Public Hearing

**DISCUSSION**

A. KEY ISSUES

1. Evaluation/Discussion

The discretionary review authority that local jurisdictions have over the deployment of wireless communication facilities, especially in the public right-of-way, is largely preempted by federal and state law. The County's authority is limited to aesthetic considerations such as consistency with any established local standards and design guidelines. Recently adopted Federal Communications Commission (FCC) regulations may further limit local jurisdictions review authority over these types of facilities.

Federal Law – Health Impacts

Many concerns regarding the establishment of wireless communication facilities relate to potential adverse health impacts generated by the facility's radio frequency emissions. However, federal law (The Wireless Communications Act of 1996) prohibits local jurisdictions from considering perceived health effects when taking an action on a proposed facility. The radio frequency levels are established and regulated by the FCC. In addition, federal law prohibits local jurisdictions from establishing regulations or taking actions which would effectively preclude a wireless communications provider from delivering service.

Public Utility Code

The California Public Utility Code (PUC) contains provisions that limit local jurisdictions' authority to deny proposed wireless communication facilities within the public right-of-way. PUC Section 7901 establishes that phone companies "may construct lines...along and upon any public road or highway..., in such a manner and at such points as not to incommode the public use of the road or highway..."

## Neighborhood Concerns

Concerns from multiple individuals have been received by the Planning Department regarding the proposed facilities. The major concerns raised by the neighborhood include: (1) the health effects of the proposed facilities, (2) how to ensure that the facilities will stay within the emissions limits that were projected in the RF report, (3) the unwanted noise associated with the proposed facilities, (4) the facilities' impact on property values, and (5) the ability (and structural integrity) of the poles themselves to safely support the proposed facilities. A brief response to these concerns are outlined below:

### *Potential Health Effects*

Small cell facilities are designed to concentrate energy toward the horizon with little wasted energy toward the sky or ground. This means that maximum RF exposure only occurs when an individual is extremely close to the wireless antenna. As stated in Section 4.a, worst-case assumptions including the assumption the Verizon equipment will always operate at maximum power, that there will be large RF reflections from ground and nearby structures, and that there will be no signal attenuation from trees, buildings, or other objects were used to calculate the RF exposure levels predicted in the RF reports. These assumptions generally result in overstated RF exposure levels that are 2-10 times greater than what is experienced in the field. Though the County's Wireless Telecommunication Ordinance does not identify RF emissions limits, it does require wireless facilities to maintain compliance with FCC regulations and licensing/registration rules. Section 704 of the Federal Telecommunications Act of 1996 contains provisions for the restriction of such emission limits and states...*no State or local government or instrumentality thereof may regulate the placement, construction, and modification of personal wireless service facilities on the basis of the environmental effects of radio frequency emissions to the extent that such facilities comply with the [Federal Communications] Commission's regulations concerning such emissions.* Though some areas directly in front of the antennas (45-50 feet above grade) may exceed Maximum Permissible Exposure (MPE) limits, wireless facilities are only considered out of compliance with FCC regulations if there are no RF hazard mitigation measures in place (i.e., signage, which these facilities will have). Given this language, the proposed projects comply with all FCC health and safety regulations.

### *RF Limits*

This question was posed to EBI (the RF engineer). EBI stated that they use modeling software that has been approved by the FCC and that their reports are conducted based on worse case scenarios by assuming that the antennas are operating at maximum power and that there is no signal attenuation from trees, buildings, or other objects. Using this predictive modeling, EBI noted that while emissions should never reach the levels

projected in the RF report, the proposed projects meet all FCC exposure standards.

### *Noise*

The proposed facilities will draw power directly from the power lines located on the existing utility poles and will not require a generator or battery to operate or provide emergency power. Furthermore, the proposed antennas are passive devices cooled by natural air flow, do not require cooling fans, and thus do not emit noise. In addition, the construction and maintenance of the proposed facilities will be regulated by the San Mateo County Ordinance Code Section 4.88.360.

### *Property Values*

In response to these concerns, the applicant provided a copy of a study conducted by the Joint Venture of Silicone Valley. This 2012 study explored this issue and found that proximity to a wireless facility had no apparent impact on property values. The study identified 70 wireless facilities located in Palo Alto, Redwood City, Saratoga, and San Jose and evaluated the “list” and “sale” price of all home transactions located within a 1-mile radius of the identified cellular facilities. The study evaluated over 1,600 single-family home transactions and found that homes located within a 1-mile radius from existing wireless facilities sold for 99% to 106% of their listing price and concluded that the relationship between the list and sale price of a home remained the same across multiple cities regardless of their proximity to a cell site.

### *Structural Integrity of the Facility/Safety Concerns*

Public comments raised a concern that the placement of the facilities above the powerlines will add stress and strain to the existing utility poles and pose a safety risk for residents and those who utilize the roadway below. In response to these concerns, the applicant has stated that this bracket and antenna configuration is a standard design for the Bay Area. Prior to its implementation, this design was reviewed by Verizon Wireless’ RF and structural engineers to ensure its structural integrity. The applicant has stated that PG&E has reviewed the project utility poles and has determined that the existing poles can safely support the proposed wireless facilities.

## 2. Compliance with the General Plan

Staff has determined that the proposed projects comply with the all applicable County General Plan policies, specifically:

## Visual Quality Policies

Policy 4.21 (*Utility Structures*) requires minimizing adverse visual impacts generated by utility structures. The project sites are located within the public right-of-way (ROW) along local roads in single-family residential areas. To reduce the visual impacts of the proposed projects, the antennas and mounted equipment, located 49'-6" to 59'-6" above grade, will be painted to match the existing utility poles and shall be constructed of non-reflective materials.

### 3. Compliance with the Zoning Regulations

The proposed project areas are located within the public ROW in the R-1/S-7 (Woodside), R-1/S-9 (Burlingame Hills) Zoning Districts. Zoning district standards, with the exception of height are not applicable to projects located within the public right-of-way.

The maximum height allowed in the R-1/S-7 and R-1/S-9 Zoning Districts is 36 feet. The proposed projects consist of a 7-foot pole extension, one cylindrical cell antenna (approximately 4 feet tall), and ancillary pole mounted equipment. The proposed antennas and extension brackets will exceed the maximum height allowed in the above mentioned zoning districts. General Order No. 95 (GO-95), mandated by the California Public Utility Commission, requires a 6-foot vertical separation between all cellular antennas and the nearest adjacent power supply lines. With power supply lines located at the top of the poles and communication lines located in the middle of the existing utility poles, the applicant has proposed to extend the height of the utility poles by placing a 7-foot<sup>1</sup> extension bracket on top of the existing poles to achieve the required State mandated 6-foot safety separation. With the addition of the brackets and the proposed antennas, an average of 11 feet will be added to the existing utility poles as outlined in the table below:

Item No.	Planning Case No.	Zoning District	Maximum Height Allowed in Zoning District	Existing Pole Height	Proposed Pole and Equipment Height
Item 1	PLN 2018-00090	R-1/S-10	36 ft.	38'8"	49'.11"
Item 2	PLN 2018-00089	R-1/S-9	36 ft.	38'6"	49'-6"
Item 3	PLN 2018-00092	R-1/S-7	36 ft.	56 ft.	59'-6"

Section 6512.2.1.2 (*Development and Design Standards for New Wireless Facilities That Are Not Co-Location Facilities*) of the San Mateo County

<sup>1</sup> The extension brackets only come in 3-, 5-, and 7-foot models.

Zoning Regulations state that, in any Residential (R) District, no monopole or antenna shall exceed the maximum height for structures allowed in that district, except that new equipment on an existing facility in the public ROW shall be allowed to exceed the maximum height for structures allowed in that district by 10% of the height of the existing facility, or by 5 feet, whichever is less.

As outlined in the chart above, the proposed projects will exceed the allowed height for new facilities in the ROW and will not be in compliance with Section 6512.2.1.2. The applicant requests that the proposed projects be permitted to exceed the height criteria outlined in Section 6512.2.1.2 in order to comply with the safety and engineering requirements of GO-95. While the alternative site analyses submitted by the applicant (Attachments C3, D3 and E3) did identify nearby alternative utility poles, these poles either: (1) did not have adequate space to support the proposed equipment or, (2) the equipment would require extension brackets to comply with the GO-95 and thus exceed the height criteria of Section 6512.2.1.2. As illustrated by the alternative analyses, if the additional height is not granted the proposed projects could not be located on any of the nearby utility poles. As small cell facilities are designed to unload traffic from macro sites and only cover a 500- to 700-foot radius, these projects must be located within or in close proximity to identified target areas. Verizon Wireless cannot effectively extend service to these areas if these projects cannot be placed on utility poles within these identified target areas.

The imposition of the County's height regulations in conjunction with the requirements of GO-95 would effectively prohibit the installation of wireless facilities in these identified service areas due to the fact that: (1) no other feasible alternative sites were identified, (2) local jurisdictions cannot require wireless facilities to locate outside of the right-of-way, and (3) local jurisdictions cannot require providers to consider alternatives outside of the right-of-way. When the application of the County's height criteria results in the effective prohibition of wireless facilities, local regulations (i.e., height in this case) are preempted by federal law. In this instance, though the proposed projects will exceed the height limits of their respective zoning district, State (i.e., GO-95) and Federal regulations supersede local regulations.

4. Compliance with the Wireless Telecommunication Facilities Ordinance

Staff has reviewed these projects against the provisions of the Wireless Telecommunications Facilities (WTF) Ordinance and determined that the projects comply with the applicable standards discussed below:

a. Development and Design Standards

**Section 6512.2.A prohibits location in a Sensitive Habitat as defined by Policy 1.8 of the General Plan for facilities proposed outside the Coastal Zone.**

The proposed projects are not located in or near mapped sensitive habitats, as defined by Policy 1.8 of the General Plan.

**Section 6512.2.B prohibits wireless facilities to be located in residential-zoned areas, unless the applicant demonstrates that no other site allows feasible or adequate capacity and coverage. Evidence shall include an alternative site analysis within 2.5 miles of the proposed facility.**

The proposed facilities will be located on existing joint utility poles in the public ROW with the R-1/S-7 and R-1/S-9 Zoning Districts. Small cell technology requires sites to be much closer together than larger macro sites. These sites are not meant to increase the coverage of an area but to assist with unloading traffic from the macro site network to provide increased data speeds and decrease dropped calls for the surrounding residences and transient traffic. As such, small cell facilities are frequently located in residential neighborhoods where data traffic is high. Though the WTF Ordinance requires applicants to demonstrate the need for wireless facilities through the submittal of propagation maps and alternative analyses, wireless providers have a state mandated right to place their facilities in the public ROW (California Public Utilities Code Section 7901), and recent legal developments indicate that wireless providers are not required to consider alternatives outside of the ROW, nor prove the need for their facilities when they are located in the right-of-way. Consequently, the County's ability to request information demonstrating the need for proposed facilities in the public ROW is limited. As such, propagation maps and the 2.5-mile alternative site analyses were not submitted for these projects (see below for further discussion).

**Section 6512.2.C C prohibits wireless telecommunication facilities to be located in areas where co-location on existing facilities would provide equivalent coverage with less environmental impact.**

The small cell technology proposed by the applicant is the least environmentally impactful wireless technology currently available. As small cell technology requires sites to be located in close proximity to one another and closer to targeted service areas, co-locating small cell sites on macro cell towers (which are often located far outside service areas) is often infeasible. As such, a 2.5-mile radius alternative map does not identify feasible alternative locations. Instead of



providing a 2.5-mile radius map, the applicant has identified and researched alternative sites within the required service areas. These alternative site analyses (Attachments C3, D3, and E3) assessed the feasibility of locating the proposed small wireless facilities on nearby joint utility poles. The utility poles identified in the alternative site analyses would either require significant tree trimming, or could not meet GO-95 safety separation standards. As such, the applicant was unable to identify any existing wireless facilities or alternative poles that would allow an opportunity for co-location or provide the necessary coverage to the target area.

**Section 6512.2.D requires wireless telecommunication facilities to be constructed so as to accommodate and be made available for co-location unless technologically infeasible.**

Future co-locations are technically feasible as long as the proposed facilities comply with GO-95 engineering requirements. As pole top mounted facilities cannot accommodate additional wireless facilities in a manner that complies with both PG&E and GO-95 requirements, the applicant does not expect future co-locations given the present equipment configuration of the utility poles.

**Sections 6512.2.E and F seek to minimize and mitigate visual impacts from public views by siting new facilities outside of public view, using natural vegetation for screening, painting equipment to blend with existing landscaping, and designing the facility to blend in with the surrounding environment.**

The proposed facilities include a 4-foot cylindrical antenna attached to a 7-foot pole extension and ancillary equipment boxes mounted onto an existing joint utility pole. The equipment boxes will be located 7 to 18 feet above grade while the top of the antennas will be located between 49'-6" and 59'-6" above grade. To mitigate the visual impact of the proposed projects, the antennas and utility boxes shall be painted a non-reflective brown color to blend-in with the existing utility pole (Condition of Approval No. 4). No trees or vegetation are proposed for removal to accommodate the proposed projects.

**Section 6512.2.G requires that the exterior of wireless telecommunication facilities be constructed of non-reflective materials.**

The proposed facilities shall be constructed of non-reflective materials, and as stated in the section above, shall be painted a non-reflective brown color to blend-in with the existing utility pole.

**Section 6512.2.H requires that wireless telecommunication facilities comply with all the requirements of the underlying zoning district, including, but not limited to setbacks.**

The existing utility poles are situated in the public right-of-way. As discussed in Section 2 above, zoning district standards (with the exception of height) are not applicable to wireless facilities located in the right-of-way.

**Section 6512.2.I.2 requires that no new equipment located on existing facilities in the public right-of-way in any Residential (R) District shall be allowed to exceed the maximum height for structures allowed in that district by 10% of the height of the existing facility, or by 5 feet, whichever is less.**

General Order No. 95 (GO-95) requires a 6-foot vertical safety separation between all wireless facilities and the nearest adjacent powerlines for facilities located on utility poles. Due to the height of the existing utility poles, and the 4-foot height of the antennas, the proposed projects are not in compliance with this section and will exceed the height limits of their respective zoning district. Imposition of the County's height regulations in conjunction with the requirements of GO-95 would effectively prohibit the installation of wireless facilities in these areas. Such a prohibition is preempted by Federal law. Because wireless carriers: (1) have a state mandated right to utilize the public ROW, (2) must abide by a 6-foot safety separation (GO-95), and (3) are not required to consider alternative sites outside the ROW, this is a situation in which State and Federal regulations supersede location regulations (i.e., height criteria). As such, the height of the proposed facilities has been designed to comply with the State's minimum safety requirements for clearance between the proposed equipment and the powerlines and limit the overall height of the structures as much as possible.

**Section 6512.2.J seeks to regulate the size, quantity, and location of accessory buildings required for wireless facilities located in any Residential (R) District.**

No accessory buildings or ground floor equipment boxes are required for these projects. The equipment boxes necessary for these projects are small in size and will be mounted on the existing utility poles.

**Section 6512.2.K requires the overall footprint of a facility to be as minimal as possible and not cover more than 15% in area of the lot or an area greater than 1,600 sq. ft. in residential districts.**

No new ground structures will be built or utilized to support the operation of these wireless telecommunication facilities. All required

utility boxes will be small in size and mounted between 7 to 18 feet above grade on the utility poles.

**Section 6512.2.L prohibits diesel generators as emergency power sources unless electricity, natural gas, solar, wind or other renewable energy sources are not feasible.**

No generators are proposed.

b. Performance Standards

The proposed projects meet the required standards of Section 6512.3 (*Performance Standards for New Wireless Telecommunication Facilities that are Not Co-Location Facilities*) for lighting, licensing, provision of a permanent power source, timely removal of the facility, and visual resource protection. There is no lighting proposed, proper licenses will be obtained from both the Federal Communications Commission (FCC) and the California Public Utilities Commission (CPUC), power for the facilities will be provided by PG&E, visual impacts will be minimal, and conditions of approval will require maintenance and/or removal of the facilities when they are no longer in operation. Furthermore, road access to the proposed project sites is existing and no noise in excess of San Mateo County's Noise Ordinance will be produced.

5. Compliance with the Use Permit Findings

For the use permits to be approved by the Zoning Hearing Officer, the following findings must be made:

- a. **That the establishment, maintenance and/or conducting of the use will not, under the circumstances of this particular case, be detrimental to the public welfare or injurious to property or improvements in said neighborhood.**

The proposed wireless facilities will be unmanned and serviced twice a year by a Verizon technician. As such, the maintenance of these facilities will not generate significant traffic, noise, or be detrimental to the public welfare.

Cellular communication facilities, such as the proposed projects, require the submittal and review radio frequency (RF) reports to ensure that the RF emissions from the proposed antennas do not exceed the Federal Communications Commission's (FCC) public exposure limits. The applicant submitted radio frequency reports prepared by EBI Consulting (EBI), dated January, February, and September of 2018, confirming that the proposed facilities will comply with the prevailing standards for limiting public exposure to

radio frequency energy and thus, will not cause a significant impact on the environment (Attachments C4, D4 and E4). The reports state that the maximum RF exposure experienced at ground level is expected to range from 3.00% to 7.2% of the applicable public exposure limit (see Table 2 below). It should be noted that these results include several “worst-case” assumptions and therefore are expected to overstate actual power density levels from the proposed operation.

Table 2			
Item No.	Planning Case No.	Approximate Location	Radio Frequency Exposure at Ground Level
Item 1	PLN 2018-00090	Hillside Drive, BGH	7.20 %
Item 2	PLN 2018-00089	Valdeflores, Drive, BGH	7.20%
Item 3	PLN 2018-00093	Cañada Road, WDS	3.00%

Though exposure to RF radiation falls within the Maximum Permissible Exposure (MPE) limits for the general public, the facilities do emit RF radiation that exceed these limits along the upper 10-15 feet of their respective poles. However, these exposures occur roughly 45 to 50 feet above ground level and are not accessible to the general public. Though these areas do exceed the MPE limits, a wireless communication facility is only considered to be out of compliance with FCC’s rules and regulations if there are areas that exceed the FCC limits and if there are no RF hazard mitigation measures in place (i.e., warning signs). As recommended by the RF reports, all project poles will be required to post caution signs on the poles (Condition of Approval No. 16) to bring these sites into compliance with the FCC’s rules and regulations. Staff has determined that the proposed projects will not be detrimental to the public welfare, or injurious to property or improvements to the unincorporated Burlingame Hills or Woodside areas of San Mateo County.

**b. That this telecommunication facility is necessary for the public health, safety, convenience or welfare of the community.**

Staff has determined that installation of a cellular facility at these locations will allow for increased clarity, range, and capacity of the existing cellular network and will enhance services for the public. The proposed facilities are the least intrusive option available to expand Verizon Wireless’s network capacity and service coverage in these areas of Burlingame Hills and Woodside. The proposed facilities will use existing utility infrastructure and add small equipment without disturbing the overall character of the neighborhood.

B. ENVIRONMENTAL REVIEW

These projects are categorically exempt pursuant to Section 15303, Class 3, of the California Environmental Quality Act (CEQA) related to the construction of a new, small structure and installation of small new equipment and a facility in a small structure.

C. REVIEWING AGENCIES

Building Inspection Section  
Department of Public Works  
Cal-Fire

**ATTACHMENTS**

- A. Recommended Findings and Conditions of Approval
- B. Vicinity Maps
- C1-C4. PLN 2018-00089 Project Plans, Photo Simulations, Alternative Analysis, Radio Frequency Radiation Reports prepared by EBI Consulting.
- D1-D4. PLN 2018-00090 Project Plans, Photo Simulations, Alternative Analysis, Radio Frequency Radiation Reports prepared by EBI Consulting.
- E1-E4. PLN2018-00092 Project Plans, Photo Simulations, Alternative Utility Pole Sites Radio Frequency Radiation Reports prepared by EBI Consulting.

TP:pac - TGPCC0569\_WPU.DOCX

County of San Mateo  
Planning and Building Department

**RECOMMENDED FINDINGS AND CONDITIONS OF APPROVAL**

Permit or Project File Numbers:

Hearing Date: December 20, 2018

Item 1	PLN 2018-00090
Item 2	PLN 2018-00089
Item 3	PLN 2018-00092

Prepared By: Tiare Peña  
Project Planner

For Adoption By: Zoning Hearing Officer

**RECOMMENDED FINDINGS**

Regarding the Environmental Review, Find:

1. That these projects are categorically exempt from environmental review, per Class 3, Section 15303, of the California Environmental Quality Act (CEQA) Guidelines for construction of a new, small structure and the installation of small new equipment and a facility in a small structure.

Regarding the Use Permit, Find:

2. That the establishment, maintenance, and/or conducting of the use will not, under the circumstances of this particular case, result in a significant adverse impact, or be detrimental to the public welfare or injurious to the property or improvements in said neighborhood because the projects will meet the health and safety standards set by the California Public Utilities Commission (CPUC) and the Federal Communications Commission (FCC). The project has been conditioned to maintain a valid FCC license.
3. That these telecommunications facilities are necessary for the public health, safety, convenience, or welfare of the community. The proposed facilities contribute to an enhanced Verizon wireless network for increased clarity, range, and system capacity, and therefore, are a benefit to both public and private users. The wireless network will be utilized by residents, commuters, and emergency personnel and is considered necessary for public health, safety, convenience, and welfare for the area.

## **RECOMMENDED CONDITIONS OF APPROVAL**

### **Current Planning Section**

1. This approval applies only to the proposal, documents, and plans described in this report and submitted to and approved by the Zoning Hearing Officer on December 20, 2018. Minor revisions or modifications may be approved by the Community Development Director if they are consistent with the intent of and in substantial conformance with this approval.
2. These use permits shall be for the proposed projects only. Any modification or change in intensity of use shall require an amendment to the use permit. Amendments to these use permits require an application for amendment, payment of applicable fees, and consideration at a public hearing prior to any changes to the facilities.
3. These permits shall be valid for ten (10) years until December 20, 2028. If the applicant seeks to renew these permits, renewal shall be applied for six (6) months prior to expiration with the Planning and Building Department and shall be accompanied by the renewal application and fee applicable at that time. Renewal of these permits shall be considered at a public hearing.
4. The applicant shall paint the antennas and associated ancillary boxes a non-reflective brown color to match the existing utility poles. Color verification will be confirmed by the Current Planning Section prior to a final inspection for the building permit.
5. During project construction, the applicant shall, pursuant to Chapter 4.100 of the San Mateo County Ordinance Code, minimize the transport and discharge of stormwater runoff from the construction site into storm drain systems by:
  - a. Stabilizing all denuded areas and maintaining erosion control measures continuously between October 1 and April 30. Stabilizing shall include both proactive measures, such as the placement of hay bales or coir netting, and passive measures, such as revegetating disturbed areas with plants propagated from seed collected in the immediate area.
  - b. Storing, handling, and disposing of construction materials and wastes properly, so as to prevent their contact with stormwater.
  - c. Controlling and preventing the discharge of all potential pollutants, including pavement cutting wastes, paints, concrete, petroleum products, chemicals, wash water or sediments, and non-stormwater discharges to storm drains and watercourses.
  - d. Avoiding cleaning, fueling, or maintaining vehicles on-site, except in a designated area where wash water is contained and treated.

- e. Delineating with field markers clearing limits, easements, setbacks, sensitive or critical areas, buffer zones, trees, and drainage courses.
  - f. Protecting adjacent properties and undisturbed areas from construction impacts using vegetative buffer strips, sediment barriers or filters, dikes, mulching, or other measures as appropriate.
  - g. Performing clearing and earth-moving activities only during dry weather.
  - h. Limiting and timing application of pesticides and fertilizers to prevent polluted runoff.
  - i. Limiting construction access routes and stabilizing designated access points.
  - j. Avoiding tracking dirt or other materials off-site; cleaning off-site paved areas and sidewalks using dry sweeping methods.
  - k. The contractor shall train and provide instruction to all employees and subcontractors regarding the construction best management practices.
6. These permits do not allow for the removal of any trees. Any tree removal will require a separate permitting process.
  7. The applicant shall not enter into a contract with the landowner or lessee which reserves for one company exclusive use of structures on this site for telecommunications facilities.
  8. The wireless telecommunications facilities shall not be lighted or marked unless required by the Federal Communications Commission (FCC) or the Federal Aviation Administration (FAA).
  9. The applicant shall file, receive, and maintain all necessary licenses and registrations from the Federal Communications Commission (FCC), the California Public Utilities Commission (CPUC), and any other applicable regulatory bodies prior to initiating the operation of these facilities. The applicant shall supply the Planning and Building Department with evidence of each of these licenses and registrations. If any required license is ever revoked, the applicant shall inform the Planning and Building Department of the revocation within ten (10) days of receiving notice of such revocation.
  10. The applicant shall paint the antenna, conduit, and equipment boxes a non-reflective brown color to match the utility pole. Two copies of each color sample shall be submitted to the Current Planning Section at the time of application for an encroachment permit. Color verification will be confirmed by the Current Planning Section prior to a final inspection for the encroachment permit.



11. The wireless telecommunication facilities and all equipment associated with it shall be removed in its entirety by the applicant within 90 days if the FCC and/or CPUC license and registration are revoked or the facility is abandoned or no longer needed, and the sites shall be restored to blend with the surrounding area. The owner and/or operator of the wireless telecommunication facilities shall notify the Planning Department upon abandonment of the facility. Restoration shall be completed within two (2) months of the removal of the facility.
12. These wireless telecommunications facilities shall be maintained by the permittee(s) and subsequent owners in a manner that implements visual resource protection requirements of Section 6512.2.E and F above (e.g., painting), as well as all other applicable zoning standards and permit conditions.
13. Noise sources associated with demolition, construction, repair, remodeling, or grading of any real property shall be limited to the hours from 7:00 a.m. to 6:00 p.m., weekdays and 9:00 a.m. to 5:00 p.m., Saturdays. Said activities are prohibited on Sundays, Thanksgiving, and Christmas (San Mateo Ordinance Code Section 4.88.360).
14. If technically practical and without creating any interruption in commercial service caused by electronic magnetic interference (EMI), floor space, tower space and/or rack space for equipment in a wireless telecommunication facility shall be made available to the County for public safety communication use.
15. To reduce the impact of construction and maintenance activities within the public right-of-way and/or on neighboring properties, the applicant shall ensure that no construction-related vehicles impede through traffic along Hillside Drive, Valdeflores Drive and Cañada Road or other public right-of-ways.
16. Caution signs are required to be posted 10-15 feet below the antennas readily visible from any angle of approach to person who might need to work within the project area as recommended by the attached RF reports.
17. If a less visually obtrusive/reduced antenna technology becomes available for use during the life of this project, the applicant shall present a redesign incorporating this technology into the project for review by the Community Development Director and any parties that have expressed an interest.

#### Department of Public Works

18. No proposed construction work within the County right-of-way shall begin until County requirements for the issuance of an encroachment permit, including review of the plans, have been met and an encroachment permit issued. Applicant shall contact a Department of Public Works Inspector 48 hours prior to commencing work in the right-of-way.

TP:pac - TGPCC0569\_WPU.DOCX



**County of San Mateo - Planning and Building Department**

# **ATTACHMENT B**

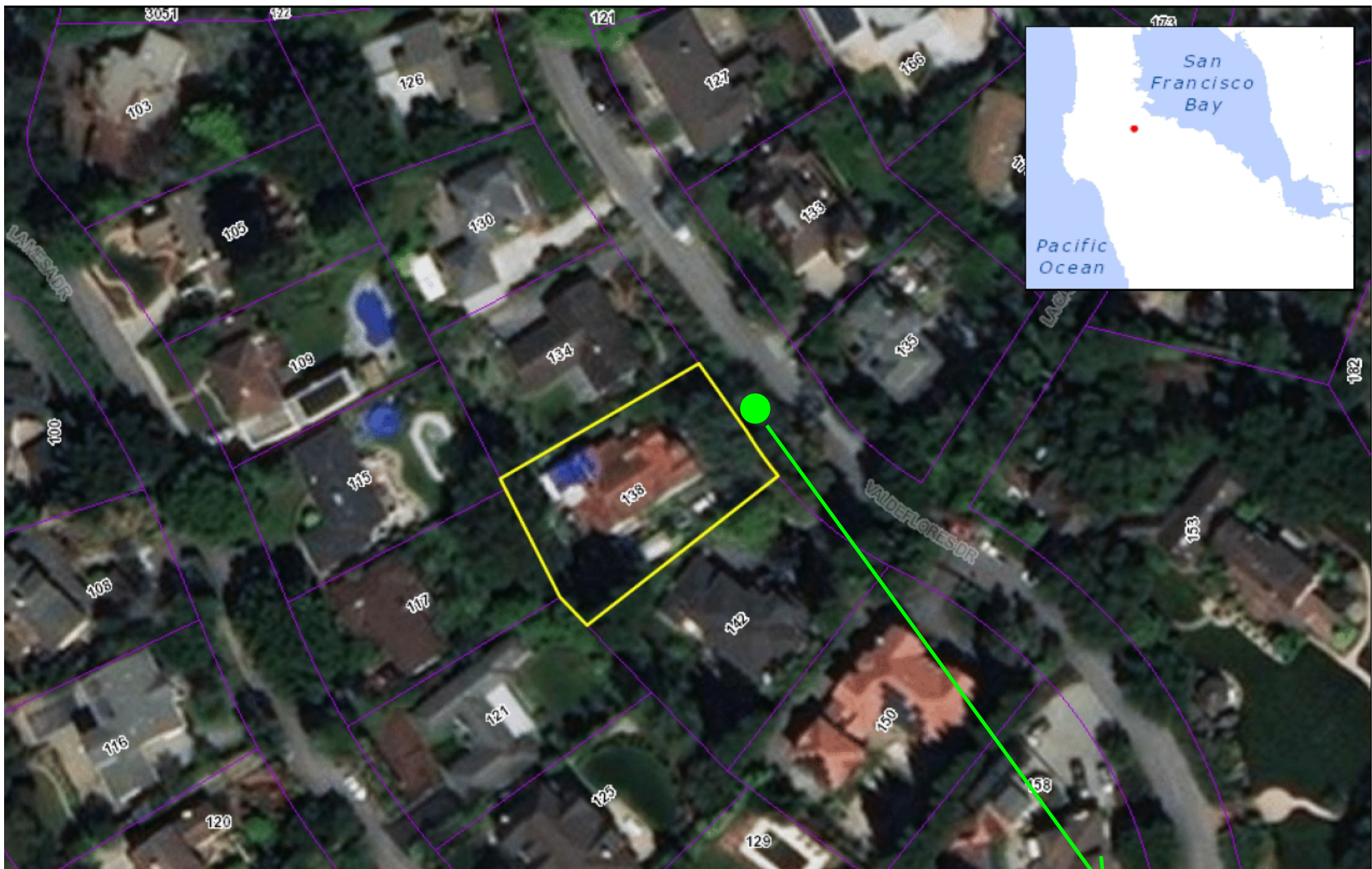

Approximate location of existing utility pole

PLN2018-00089

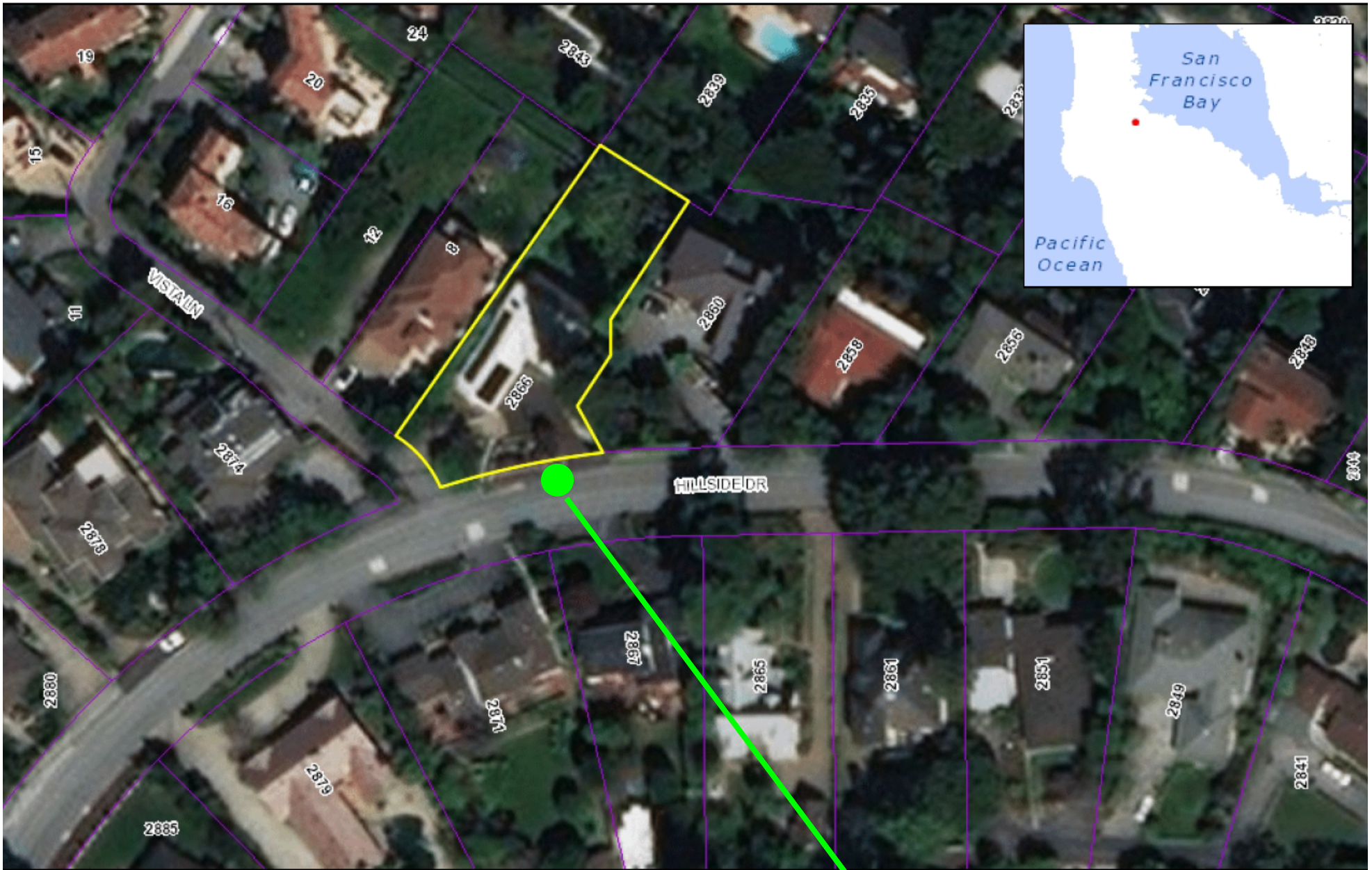

PLN2018-00090

Approximate location of existing utility pole



PLN2018-00092

Approximate location of existing utility pole



**County of San Mateo - Planning and Building Department**

# **ATTACHMENT C-1**



**SITE NAME:** SF BURLINGAME 018  
**PROJECT ID#:** BUR\_018  
**LOCATION:** 438499  
**SITE ADDRESS:** 138 VALDEFLORES DR  
 BURLINGAME, CA 94010  
**COUNTY:** SAN MATEO  
**SITE TYPE:** PG&E POLE TOP



2785 MITCHELL DRIVE, SUITE 9  
 WALNUT CREEK, CA 94598



modus-corp.com

240 STOCKTON STREET, 3RD FLOOR  
 SAN FRANCISCO, CA 94108



borgesarch.com

1478 STONE POINT DRIVE, SUITE 350  
 ROSEVILLE CA 95661  
 916 782 7200 TEL  
 916 773 3037 FAX

**PROJECT DESCRIPTION**

THIS IS AN UNMANNED WIRELESS TELECOMMUNICATION FACILITY FOR VERIZON WIRELESS CONSISTING OF THE INSTALLATION AND OPERATION OF AN ANTENNA AND ASSOCIATED EQUIPMENT ON AN EXISTING UTILITY POLE IN THE PUBLIC RIGHT OF WAY.

**SCOPE OF WORK & SITE COMPLETION CHECKLIST**

- ANTENNA & ASSOCIATED EQUIPMENT BOXES - INSTALL A NEW TELECOMMUNICATION ANTENNA AND EQUIPMENT BOXES ON AN EXISTING WOOD UTILITY POLE ON G095 COMPLIANT STANDOFF BRACKET. INSTALLATION CONSISTS OF (1) CYLINDRICAL ANTENNA, (1) RRUS-32, (1) RRUS-2212 (1) ELECTRICAL METER, (1) LOAD CENTER & DISCONNECT SWITCH, (1) FIBER DEMARCATION BOX.
- CABLING - CABLING TO BE INSTALLED IN A TIDY MANNER WITHOUT EXCESS CABLE LOOPS
- SPACING OF SUPPORT ELEMENTS - SUPPORT EQUIPMENT (E.G. RRUS) TO BE CLUSTERED (VERTICALLY) AS CLOSE AS TECHNICALLY FEASIBLE ON POLE.
- LOGO REMOVAL - ALL EQUIPMENT LOGOS, OTHER THAN THOSE REQUIRED BY REGULATION (E.G. NODE IDENTIFICATION) SHALL BE PAINTED OVER OR REMOVED. RAISED OR DEPRESSED TEXT ON RRUS OR OTHER EQUIPMENT, IF PRESENT, SHALL BE SANDED OFF OR SIMILARLY REMOVED / FILLED.
- SIGNAGE - FCC MANDATED RF WARNING SIGNAGE SHALL FACE OUT TO STREET WHEN PLACED IN FRONT OF, OR NEAR A WINDOW. SIGNAGE SHALL FACE TOWARD A BUILDING IF THERE IS NO WINDOW.
- ALL CABLING, ANTENNAS, AND EQUIPMENT TO BE PAINTED TO MATCH POLE.

**CODE COMPLIANCE**

ALL WORK AND MATERIALS SHALL BE PERFORMED AND INSTALLED IN ACCORDANCE WITH THE CURRENT EDITIONS OF THE FOLLOWING CODES AS ADOPTED BY THE LOCAL GOVERNING AUTHORITIES. NOTHING IN THESE PLANS IS TO BE CONSTRUED TO PERMIT WORK NOT CONFORMING TO THESE CODES.

- 1) 2016 CALIFORNIA ADMINISTRATIVE CODE, CHAPTER 10, PART 1, TITLE 24 CODE OF REGULATIONS
- 2) 2016 CALIFORNIA BUILDING CODE (CBC) WITH CALIFORNIA AMENDMENTS, BASED ON THE 2015 IBC (PART 2, VOL 1-2)
- 3) 2016 CALIFORNIA RESIDENTIAL CODE (CRC) WITH APPENDIX H, PATIO COVERS, BASED ON THE 2015 IRC (PART 2.5)
- 4) 2016 CALIFORNIA GREEN BUILDINGS STANDARDS CODE (CALGREEN) (PART 11) (AFFECTED ENERGY PROVISIONS ONLY)
- 5) 2016 CALIFORNIA FIRE CODE (CFC), BASED ON THE 2015 IFC, WITH CALIFORNIA AMENDMENTS (PART 9)
- 6) 2016 CALIFORNIA MECHANICAL CODE (CMC), BASED ON THE 2015 UMC (PART 4)
- 7) 2016 CALIFORNIA PLUMBING CODE (CPC), BASED ON THE 2015 UPC (PART 5)
- 8) 2016 CALIFORNIA ELECTRICAL CODE (CEC) WITH CALIFORNIA AMENDMENTS, BASED ON THE 2015 NEC (PART 3)
- 9) 2016 CALIFORNIA ENERGY CODE (CEC)
- 10) ANSI / EIA-TIA-222-H
- 11) 2015 NFPA 101, LIFE SAFETY CODE
- 12) 2016 NFPA 72, NATIONAL FIRE ALARM CODE
- 13) 2016 NFPA 13, FIRE SPRINKLER CODE

**DISABLED ACCESS REQUIREMENTS**

FACILITY IS UNMANNED AND NOT FOR HUMAN HABITATION. ACCESSIBILITY REQUIREMENTS ARE NOT REQUIRED. IN ACCORDANCE WITH CALIFORNIA BUILDING CODE, CODE OF REGULATIONS, TITLE 24, PART 2, VOLUME 1, CHAPTER 11B, DIVISION 2, SECTION 11B-203.5

**VICINITY MAP**



**PROJECT INFORMATION**

**Property Information:**  
 Site Name: SF BURLINGAME 018  
 Site Number: BUR\_018  
 Site Address: 138 VALDEFLORES DR  
 BURLINGAME, CA 94010  
 A.P.N. Number: 027-063-270  
 Current Zoning: N/A - PUBLIC RIGHT OF WAY  
 Jurisdiction: CITY OF BURLINGAME  
 Latitude: N 37° 34' 29.76"  
 Longitude: W 122° 23' 27.79"  
 Elevation: +/-481.01' AMSL

**Power Agency:**  
 PG&E  
 1 MARKET STREET, SPEAR TOWER  
 SAN FRANCISCO, CA 94105-1126

**Telephone Agency:**  
 VERIZON WIRELESS  
 525 MARKET STREET  
 SAN FRANCISCO, CA 94105  
 ph: (415) 778-1231

**Property Owner:**  
 N/A - PUBLIC RIGHT OF WAY

**SHEET INDEX**

SHEET NO.	SHEET TITLE
T-1	TITLE SHEET
GN-1	GENERAL NOTES
C-1	SURVEY
A-1	SITE PLAN
A-2	ENLARGED SITE PLAN & ANTENNA PLAN
A-3.1	ELEVATIONS
A-3.2	ELEVATIONS
A-4.1	DETAILS
A-4.2	DETAILS
E-1	SINGLE LINE DIAGRAM & PANEL SCHEDULE
E-2	POLE GROUND & RISER DIAGRAM & DETAILS

**PROJECT TEAM**

**Agent:**  
 Scott Revard  
 Modus-Corporation, Inc.  
 240 Stockton Street, 3rd Floor  
 San Francisco, CA 94108  
 ph: (415) 595-0938  
 email: srevard@modus-corp.com

**Project Manager:**  
 Scott Revard  
 Modus-Corporation, Inc.  
 240 Stockton Street, 3rd Floor  
 San Francisco, CA 94108  
 ph: (415) 595-0938  
 email: srevard@modus-corp.com

**Construction Manager:**  
 Kresston Haynes  
 Modus-Corporation, Inc.  
 240 Stockton Street, 3rd Floor  
 San Francisco, CA 94108  
 ph: (209) 938-7251  
 email: khaynes@modus-corp.com

**Architect / Engineer of Record:**  
 Borges Architectural Group, Inc.  
 1478 Stone Point Drive, Suite 350  
 Roseville, CA 95661  
 contact: Brian K. Winslow  
 ph: (916) 782-7200  
 email: brian@borgesarch.com

**DIRECTIONS FROM VERIZON'S OFFICE**

DIRECTIONS FROM VERIZON WIRELESS'S OFFICE AT 2785 MITCHELL DRIVE, WALNUT CREEK, CA

1. DEPART MITCHELL DR TOWARD N WIGET LN
2. TURN LEFT ONTO N WIGET LN
3. TURN RIGHT ONTO YGNACIO VALLEY RD
4. ROAD NAME CHANGES TO HILLSIDE AVE
5. TAKE RAMP RIGHT FOR CA-24 WEST TOWARD OAKLAND
6. TAKE RAMP RIGHT FOR I-580 WEST TOWARD SACRAMENTO / SAN FRANCISCO
7. TAKE RAMP LEFT FOR I-80 WEST TOWARD SAN FRANCISCO
8. KEEP RIGHT ONTO I-80 W
9. KEEP STRAIGHT ONTO US-101 S
10. AT EXIT 423B, TAKE RAMP RIGHT FOR I-380 WEST TOWARD SAN BRUNO
11. AT EXIT 5B, TAKE RAMP LEFT FOR I-280 SOUTH TOWARD SAN JOSE
12. AT EXIT 39, TAKE RAMP RIGHT AND FOLLOW SIGNS FOR TROUSDALE DR
13. TURN LEFT ONTO TROUSDALE DR, AND THEN IMMEDIATELY TURN RIGHT ONTO SKYLINE BLVD
14. BEAR LEFT ONTO HILLSIDE DR
15. TURN RIGHT ONTO VALDEFLORES DR
16. ARRIVE AT VALDEFLORES DR

SIGNATURE BLOCK		
TITLE	SIGNATURE	DATE
VERIZON PM		
VERIZON CM		
VERIZON RF		
MODUS PM		
MODUS CM		
UTILITIES		
LANDLORD/ PROPERTY OWNER		

**OCCUPANCY AND CONSTRUCTION TYPE**

OCCUPANCY : N/A  
 CONSTRUCTION TYPE: G.O. 128 AND 2009 AASHTO 5TH EDITION STANDARD

**GENERAL CONTRACTOR NOTES**  
 DO NOT SCALE DRAWINGS

THESE DRAWINGS ARE FORMATTED TO BE FULL SIZE AT 36" x 24" (D1). CONTRACTOR SHALL VERIFY ALL PLANS AND EXISTING DIMENSIONS AND CONDITIONS ON THE JOBSITE AND SHALL IMMEDIATELY NOTIFY THE ARCHITECT/ENGINEER IN WRITING OF ANY DISCREPANCIES BEFORE PROCEEDING WITH THE WORK OR MATERIAL ORDERS OR BE RESPONSIBLE FOR THE SAME.



STAMP



DRAWN BY: D.A.G. PROJECT NO.: T-16519-48

CHECK BY: B.K.W.

SHEET TITLE

TITLE SHEET

SHEET NO.

**T-1**

**ABBREVIATIONS:**

A.B.	ANCHOR BOLT	IN. (")	INCH(ES)
ABV.	ABOVE	INT.	INTERIOR
ACCA	ANTENNA CABLE COVER ASSEMBLY	LB.(#)	POUND(S)
ADDL	ADDITIONAL	L.B.	LAG BOLTS
A.F.F.	ABOVE FINISHED FLOOR	L.F.	LINEAR FEET (FOOT)
A.F.G.	ABOVE FINISHED GRADE	L.	LONG(TUDINAL)
ALUM.	ALUMINUM	MAS.	MASONRY
ALT.	ALTERNATE	MAX.	MAXIMUM
ANT.	ANTENNA	M.B.	MACHINE BOLT
APPRX.	APPROXIMATE(LY)	MECH.	MECHANICAL
ARCH.	ARCHITECT(URAL)	MFR.	MANUFACTURER
AWG.	AMERICAN WIRE GAUGE	MIN.	MINIMUM
BLDG.	BUILDING	MISC.	MISCELLANEOUS
BLK.	BLOCK	MTL.	METAL
BLKG.	BLOCKING	(N)	NEW
BM.	BEAM	NO.(#)	NUMBER
B.N.	BOUNDARY NAILING	N.T.S.	NOT TO SCALE
BTCW.	BARE TINNED COPPER WIRE	O.C.	ON CENTER
B.O.F.	BOTTOM OF FOOTING	OPNG.	OPENING
BU	BACK-UP CABINET	(P)	PROPOSED
CAB.	CABINET	P/C	PRECAST CONCRETE
CANT.	CANTILEVER(ED)	PCS	PERSONAL COMMUNICATION SERVICES
C.I.P.	CAST IN PLACE	PLY.	PLYWOOD
CLG.	CEILING	PPC	POWER PROTECTION CABINET
CLR.	CLEAR	PRC	PRIMARY RADIO CABINET
COL.	COLUMN	P.S.F.	POUNDS PER SQUARE FOOT
CONC.	CONCRETE	P.S.I	POUNDS PER SQUARE INCH
CONN.	CONNECTION(OR)	P.T.	PRESSURE TREATED
CONST.	CONSTRUCTION	PWR.	POWER (CABINET)
CONT.	CONTINUOUS	QTY.	QUANTITY
d	DIAMETER	RAD.(R)	RADIUS
DBL.	DOUBLE	REF.	REFERENCE
DEPT.	DEPARTMENT	REINF.	REINFORCEMENT(ING)
D.F.	DOUGLAS FIR	REQD/	REQUIRED
DIA.	DIAMETER	RGS.	RIGID GALVANIZED STEEL
DIAG.	DIAGONAL	SCH.	SCHEDULE
DIM.	DIMENSION	SHT.	SHEET
DWG.	DRAWING(S)	SIM.	SIMILAR
DWL.	DOWEL(S)	SPEC.	SPECIFICATIONS
EA.	EACH	SQ.	SQUARE
EL.	ELEVATION	S.S.	STAINLESS STEEL
ELEC.	ELECTRICAL	STD.	STANDARD
ELEV.	ELEVATOR	STL.	STEEL
EMT.	ELECTRICAL METALLIC TUBING	STRUC.	STRUCTURAL
E.N.	EDGE NAIL	TEMP.	TEMPORARY
ENG.	ENGINEER	THK.	THICK(NESS)
EQ.	EQUAL	T.N.	TOE NAIL
EXP.	EXPANSION	T.O.A.	TOP OF ANTENNA
EXST.(E)	EXISTING	T.O.C.	TOP OF CURB
EXT.	EXTERIOR	T.O.F.	TOP OF FOUNDATION
FAB.	FABRICATION(OR)	T.O.P.	TOP OF PLATE (PARAPET)
F.F.	FINISH FLOOR	T.O.S.	TOP OF STEEL
F.G.	FINISH GRADE	T.O.W.	TOP OF WALL
FIN.	FINISH(ED)	TYP.	TYPICAL
FLR.	FLOOR	U.G.	UNDER GROUND
FDN.	FOUNDATION	U.L.	UNDERWRITERS LABORATORY
F.O.C.	FACE OF CONCRETE	U.N.O.	UNLESS NOTED OTHERWISE
F.O.M.	FACE OF MASONRY	V.I.F.	VERIFY IN FIELD
F.O.S.	FACE OF STUD	W	WIDE (WIDTH)
F.O.W.	FACE OF WALL	w/	WITH
F.S.	FINISH SURFACE	WD.	WOOD
FT. (')	FOOT (FEET)	W.P.	WEATHERPROOF
FTG.	FOOTING	WT.	WEIGHT
G.	GROWTH (CABINET)	C	CENTERLINE
GA.	GAUGE	L	PLATE, PROPERTY LINE
GI.	GALVANIZE(D)		
G.F.I.	GROUND FAULT CIRCUIT INTERRUPTER		
GLB. (GLU-LAM)	GLUE LAMINATED BEAM		
GPS	GLOBAL POSITIONING SYSTEM		
GRND.	GROUND		
HDR.	HEADER		
HGR.	HANGER		
HT.	HEIGHT		
ICGB.	ISOLATED COPPER GROUND BUS		

**SYMBOL LEGEND:**

	BLDG. SECTION		GROUT OR PLASTER
	WALL SECTION		(E) BRICK
	DETAIL		(E) MASONRY
	ELEVATION		CONCRETE
	DOOR SYMBOL		EARTH
	WINDOW SYMBOL		GRAVEL
	TILT-UP PANEL MARK		PLYWOOD
	PROPERTY LINE		SAND
	CENTERLINE		PLYWOOD
	ELEVATION DATUM		SAND
	GRID/COLUMN LINE		PLYWOOD
	KEYNOTE, DIMENSION ITEM		SAND
	KEYNOTE, CONSTRUCTION ITEM		(E) STEEL
	WALL TYPE MARK		MATCH LINE
	ROOM NAME		GROUND CONDUCTOR
	ROOM NUMBER		OVERHEAD SERVICE CONDUCTORS
			TELEPHONE CONDUIT
			POWER CONDUIT
			COAXIAL CABLE
			CHAIN LINK FENCE
			WOOD FENCE

**GENERAL NOTES:**

- THESE NOTES SHALL BE CONSIDERED A PART OF THE WRITTEN SPECIFICATIONS, CONTRACT AND CONSTRUCTION DOCUMENTS.
- THE WORK SHALL INCLUDE FURNISHING MATERIALS, EQUIPMENT, APPURTENANCES, AND LABOR NECESSARY TO COMPLETE ALL INSTALLATIONS AS INDICATED ON THE PLANS AND IN THE CONTRACT DOCUMENTS.
- PRIOR TO THE SUBMISSION OF BIDS, THE CONTRACTOR(S) SHALL VISIT THE JOB SITE(S) AND BE RESPONSIBLE FOR ALL CONTRACT DOCUMENTS, FIELD CONDITIONS AND DIMENSIONS, AND CONFIRM THE WORK MAY BE ACCOMPLISHED PER THE CONTRACT DRAWINGS. ANY DISCREPANCIES ARE TO BE BROUGHT TO THE ATTENTION OF THE IMPLEMENTATION ENGINEER AND ARCHITECT / ENGINEER PRIOR TO BID SUBMITTAL.
- THE CONTRACTOR SHALL RECEIVE WRITTEN AUTHORIZATION TO PROCEED ON ANY WORK NOT CLEARLY DEFINED OR IDENTIFIED IN THE CONTRACT AND CONSTRUCTION DOCUMENTS BEFORE STARTING ANY WORK.
- ALL WORK PERFORMED AND MATERIALS INSTALLED SHALL BE IN STRICT ACCORDANCE WITH ALL APPLICABLE CODES, REGULATIONS, AND ORDINANCES, INCLUDING APPLICABLE MUNICIPAL AND UTILITY COMPANY SPECIFICATIONS.
- THE CONTRACTOR SHALL INSTALL ALL EQUIPMENT AND MATERIALS IN ACCORDANCE WITH MANUFACTURER RECOMMENDATIONS. IF THE RECOMMENDATIONS ARE IN CONFLICT WITH THE CONTRACT AND CONSTRUCTION DOCUMENTS AND/OR APPLICABLE CODES OR REGULATIONS, REVIEW AND RESOLVE THE CONFLICT WITH DIRECTION FROM THE IMPLEMENTATION ENGINEER AND ARCHITECT/ENGINEER OF RECORD PRIOR TO PROCEEDING.
- THE CONTRACTOR SHALL BE SOLELY RESPONSIBLE FOR ALL CONSTRUCTION MEANS, METHODS, TECHNIQUES, SEQUENCES, AND PROCEDURES AND FOR COORDINATION OF ALL PORTIONS OF THE WORK UNDER THE CONTRACT INCLUDING CONTACT AND COORDINATION WITH THE IMPLEMENTATION ENGINEER AND WITH THE AUTHORIZED REPRESENTATIVE OF ANY OUTSIDE POLE OR PROPERTY OWNER.
- THE CONTRACTOR SHALL MAKE NECESSARY PROVISIONS TO PROTECT EXISTING IMPROVEMENTS, INCLUDING BUT NOT LIMITED TO PAVING, CURBS, VEGETATION, GALVANIZED SURFACE OR OTHER EXISTING ELEMENTS AND UPON COMPLETION OF THE WORK, REPAIR AND DAMAGE THAT OCCURRED DURING CONSTRUCTION TO THE SATISFACTION OF THE Satisfaction.
- CONTRACTOR IS TO KEEP THE GENERAL AREA CLEAN, HAZARD FREE, AND DISPOSE OF ALL DIRT, DEBRIS, RUBBISH, AND REMOVE EQUIPMENT NOT SPECIFIED AS REMAINING ON THE PROPERTY. LEAVE PREMISES IN CLEAN CONDITION DAILY.
- PLANS ARE INTENDED TO BE DIAGRAMMATIC ONLY AND SHOULD NOT BE SCALED UNLESS OTHERWISE NOTED. RELY ONLY ON ANNOTATED DIMENSIONS AND REQUEST INFORMATION IF ADDITIONAL DIMENSIONS ARE REQUIRED.
- THE EXISTENCE AND LOCATION OF UTILITIES AND OTHER AGENCY'S FACILITIES WERE OBTAINED BY A SEARCH OF AVAILABLE RECORDS. OTHER FACILITIES MAY EXIST. CONTRACTOR SHALL VERIFY LOCATIONS PRIOR TO START OF CONSTRUCTION AND USE EXTREME CARE AND PROTECTIVE MEASURES TO PREVENT DAMAGE TO THE FACILITIES. CONTRACTOR IS RESPONSIBLE FOR THE PROTECTION OF UTILITIES OR OTHER AGENCY'S FACILITIES WITHIN THE LIMITS OF THE WORK, WHETHER THEY ARE IDENTIFIED IN THE CONTRACT DOCUMENTS OR NOT.
- THE CONTRACTOR SHALL NOTIFY UNDERGROUND SERVICE ALERT (800) 227-2600, AT LEAST TWO WORKING DAYS PRIOR TO START OF ANY EXCAVATION.

**DEFINITIONS:**

- "TYPICAL" OR "TYP" MEANS THAT THIS ITEM IS SUBSTANTIALLY THE SAME ACROSS SIMILAR CONDITIONS. "TYP" SHALL BE UNDERSTOOD TO MEAN "TYPICAL WHERE OCCURS" AND SHALL NOT BE CONSIDERED AS WITHOUT EXCEPTION OR CONSIDERATION OF SPECIFIC CONDITIONS.
- "SIMILAR" MEANS COMPARABLE TO CHARACTERISTICS FOR THE CONDITION NOTED. VERIFY DIMENSIONS AND ORIENTATION ON PLAN.
- "AS REQUIRED" MEANS AS REQUIRED BY REGULATORY REQUIREMENTS, BY REFERENCES STANDARDS, BY EXISTING CONDITIONS, BY GENERALLY ACCEPTED CONSTRUCTION PRACTICE, OR BY THE CONTRACT DOCUMENTS.
- "ALIGN" MEANS ACCURATELY LOCATE FINISH FACES OF MATERIALS IN THE SAME PLANE.
- THE TERM "VERIFY" OF "V.I.F." SHALL BE UNDERSTOOD TO MEAN "VERIFY IN FIELD WITH ENGINEER" AND REQUIRES THAT THE CONTRACTOR CONFIRM INTENTION REGARDING NOTED CONDITION AND PROCEED ONLY AFTER RECEIVING DIRECTION.
- WHERE THE WORDS "OR EQUAL" OR WORDS OF SIMILAR INTENT FOLLOW A MATERIAL SPECIFICATION, THEY SHALL BE UNDERSTOOD TO REQUIRE SIGNED APPROVAL OF ANY DEVIATION TO SAID SPECIFICATION PRIOR TO CONTRACTOR'S ORDERING OR INSTALLATION OF SUCH PROPOSED EQUAL PRODUCT.
- "FURNISH" MEANS SUPPLY ONLY, OTHERS TO INSTALL.
- "INSTALL" MEANS INSTALL ITEMS FURNISHED BY OTHERS.
- "PROVIDE" MEANS FURNISH AND INSTALL.



2785 MITCHELL DRIVE, SUITE 9  
WALNUT CREEK, CA 94598



modus-corp.com

240 STOCKTON STREET, 3RD FLOOR  
SAN FRANCISCO, CA 94108



borgesarch.com

1478 STONE POINT DRIVE, SUITE 350  
ROSEVILLE CA 95661

916 782 7200 TEL  
916 773 3037 FAX

1	02/21/18	90% CD SUBMITTAL
0	10/24/17	90% CD SUBMITTAL
REV	DATE	DESCRIPTION

**SITE NUMBER:**

**BUR\_018**

**SITE ADDRESS:**  
138 VALDEFLORES DR  
BURLINGAME, CA 94010

STAMP



DRAWN BY: D.A.G. PROJECT NO.: T-16519-48

CHECK BY: B.K.W.

SHEET TITLE

**GENERAL NOTES**

SHEET NO.

**GN-1**



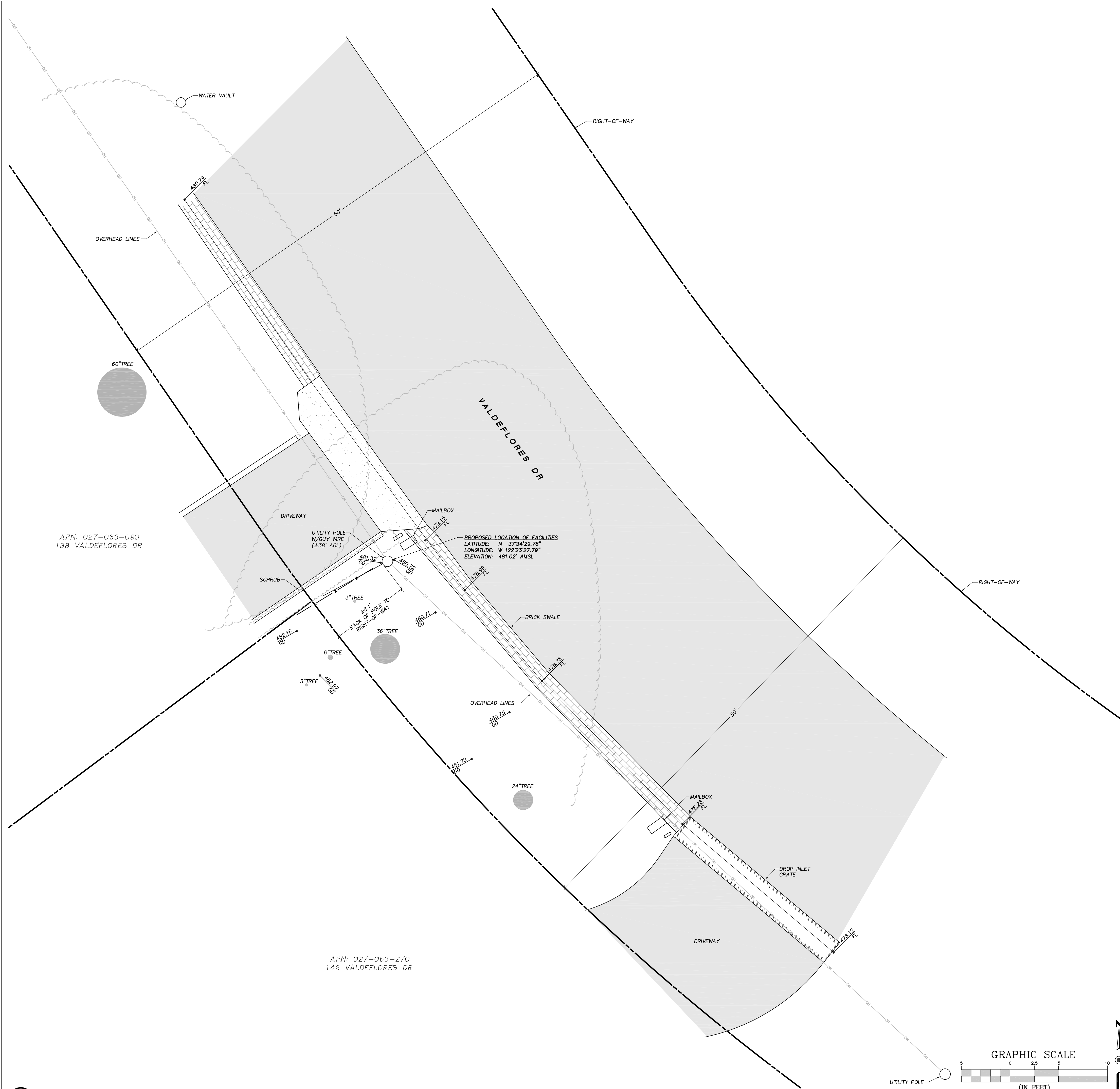

2 SITE PLAN  
SCALE: 1"=5'

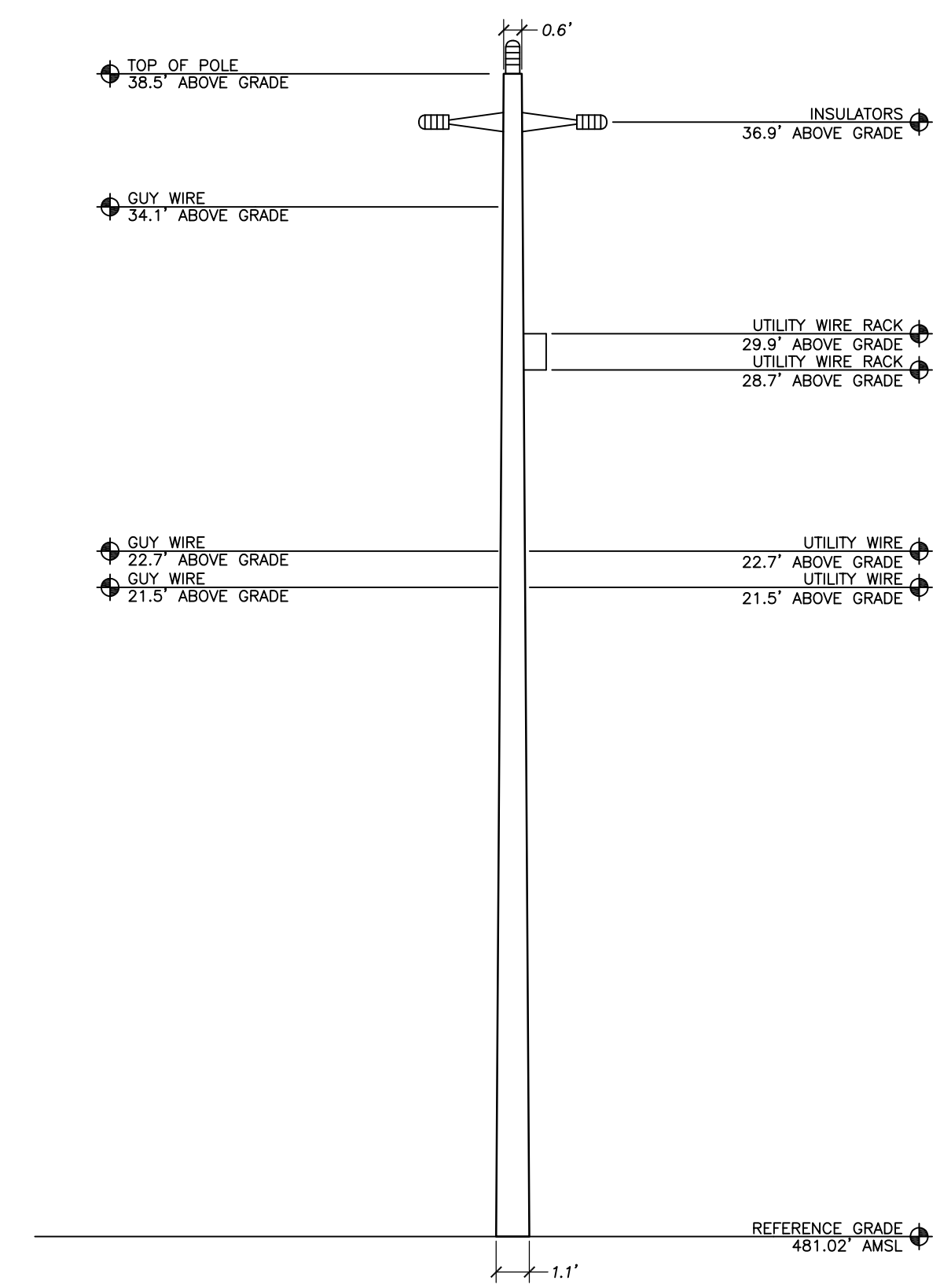

3 UTILITY POLE ELEVATION  
SCALE: 1"=5'

**BOUNDARY AND TITLE INFORMATION**

THIS MAP IS A GRAPHIC DEPICTION OF DATA COMPILED FROM MAPS AND VARIOUS OTHER INFORMATION. IT IS NOT A BOUNDARY SURVEY. THIS MAP IS A TOPOGRAPHIC MAP SHOWING PROPERTY LINES PLOTTED FROM SAID RECORD DATA AND BEST FIT ONTO EXISTING IMPROVEMENTS. THE LIMITS OF TOPOGRAPHIC DATA AND/OR IMPROVEMENTS GATHERED AND DEPICTED ARE LIMITED TO THE CONTRACTUAL SCOPE FOR THIS PROJECT. NO MONUMENTS WERE SET OR WILL BE SET. NO TITLE RESEARCH WAS PERFORMED BY OMNI DESIGN GROUP INC. PROPERTY LINE LOCATION COULD POSSIBLY SHIFT FROM LOCATIONS SHOWN HEREON SHOULD A BOUNDARY SURVEY BE PERFORMED. LOCATIONS OF EXISTING FEATURES RELATIVE TO PROPERTY LINES THEREFORE ARE APPROXIMATE.

**DATUM:**  
HORIZONTAL & VERTICAL DATUMS SHOWN ON THESE PLANS WERE OBTAINED FROM GPS OBSERVATIONS USING CALIFORNIA REAL TIME NETWORK "CRTN".

**BASIS OF BEARINGS**  
THE BEARINGS ARE BASED UPON CALIFORNIA COORDINATE SYSTEM, ZONE 3, NAD 83

**BENCHMARK:**  
THE ELEVATIONS ARE BASED UPON NAVD 88

**NOTES:**  
1. DATE OF SURVEY: 08/23/17  
2. NO UNDERGROUND UTILITIES WERE LOCATED.  
3. ADDRESS(S) AND ASSESSOR PARCEL NUMBER(S) "APN" WERE OBTAINED USING THE COUNTY OF SAN MATEO'S GIS WEBSITE. OMNI DESIGN GROUP, INC. ASSUMES NO LIABILITY FOR INFORMATION OBTAINED.

**LEGEND**  
AC = ASPHALTIC CONCRETE  
EP = EDGE OF PAVEMENT  
FL = FLOWLINE  
FS = FINISHED SURFACE  
GD = GROUND ELEVATION  
TC = TOP OF CURB  
AGL = ABOVE GRADE LEVEL  
AMSL = ABOVE MEAN SEA LEVEL

1 BOUNDARY & LEGAL DESCRIPTIONS  
SCALE: NONE

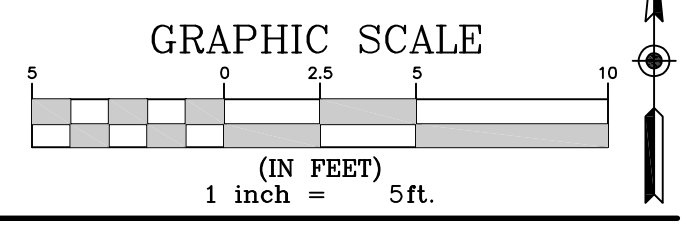

PROJECT INFORMATION:  
SF BURLINGAME 018  
VERIZON SITE #438509  
138 VALDEFLORES DR  
BURLINGAME, CA

CURRENT ISSUE DATE:  
10/19/17

ISSUED FOR:  
100% SURVEY

REV. DATE	DESCRIPTION	BY

COORDINATING ARCHITECT:  
**omni DESIGN GROUP**  
Architecture  
Civil Engineering  
Surveying  
Telecommunications  
711 Tank Farm Road, Suite 100  
San Luis Obispo, California 93401  
Phone: (805) 544-9700  
www.omnidesigngroup.com  
email: omni@odgso.com

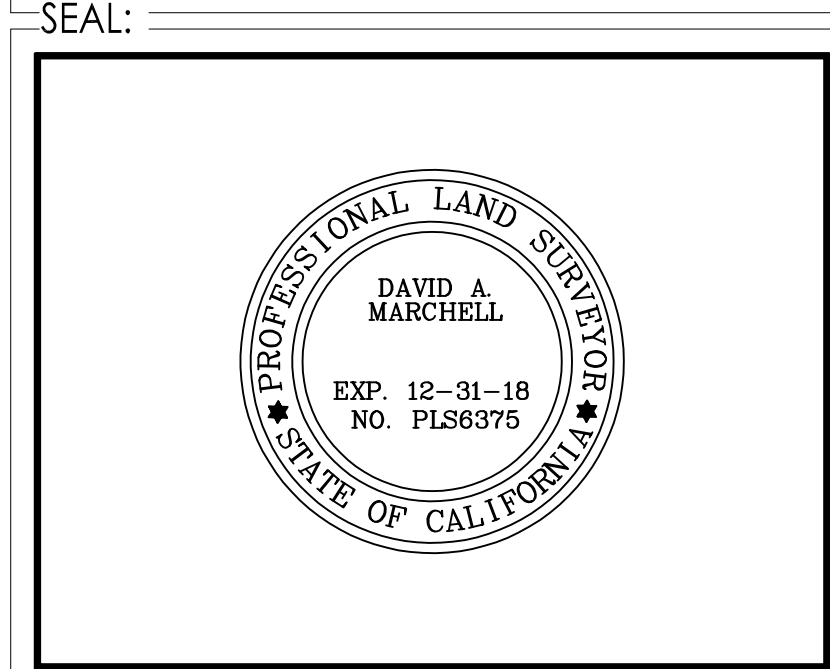

CONSULTANT:  
**Modus, Inc.**  
240 Stockton Street, 3rd Floor  
San Francisco, CA 94108

DRAWN BY: AK/DKN    CHK.: DM    APV.: DM

SHEET TITLE:  
SITE PLAN

SHEET NUMBER: C-1    REVISION: 1180-100



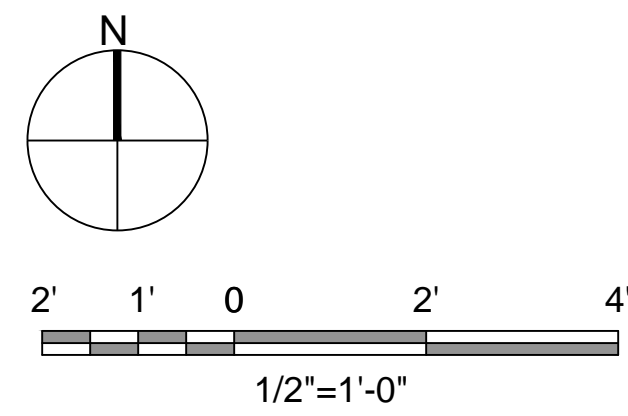
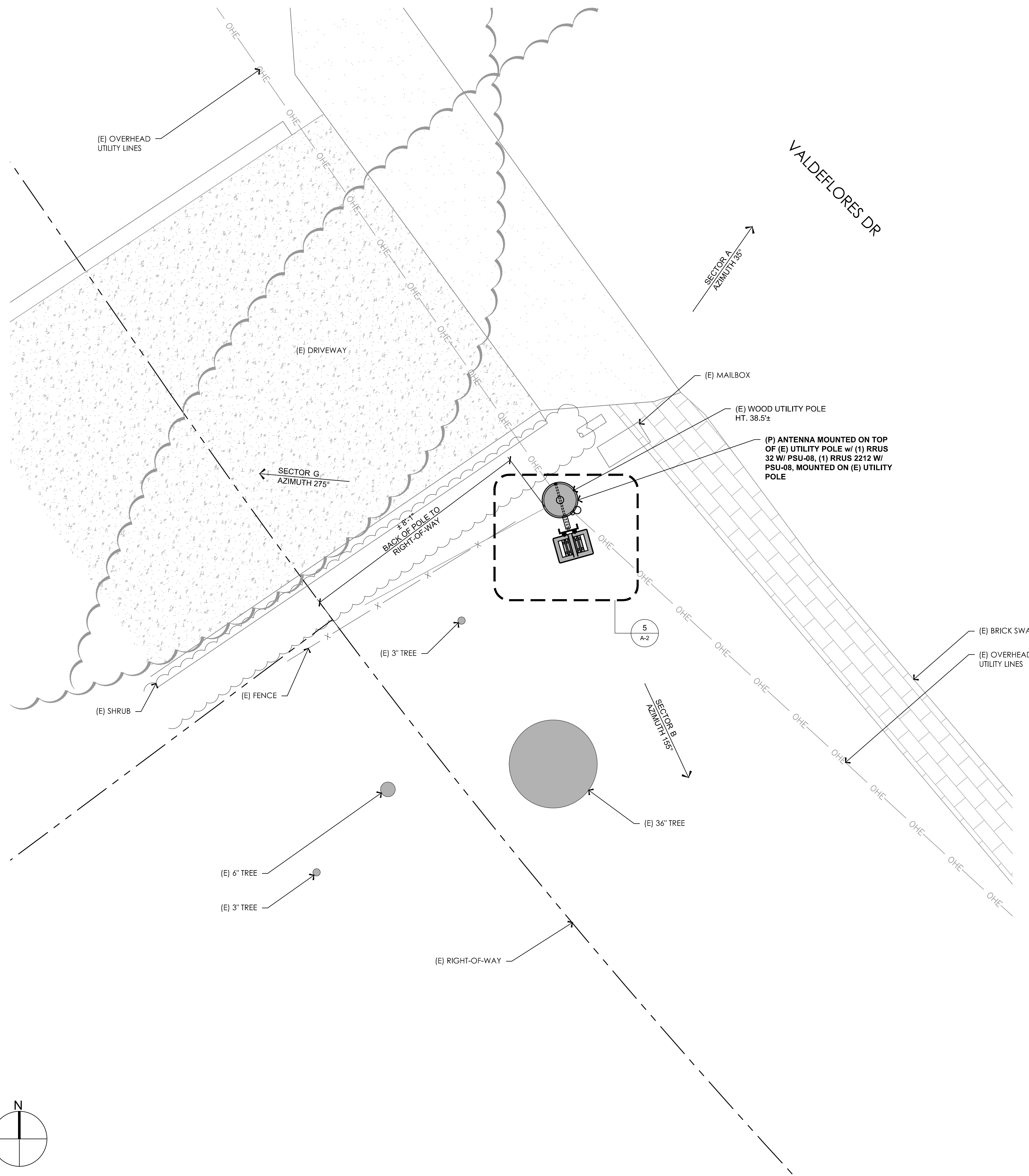

17 ENLARGED SITE PLAN  
1/2"=1'-0"

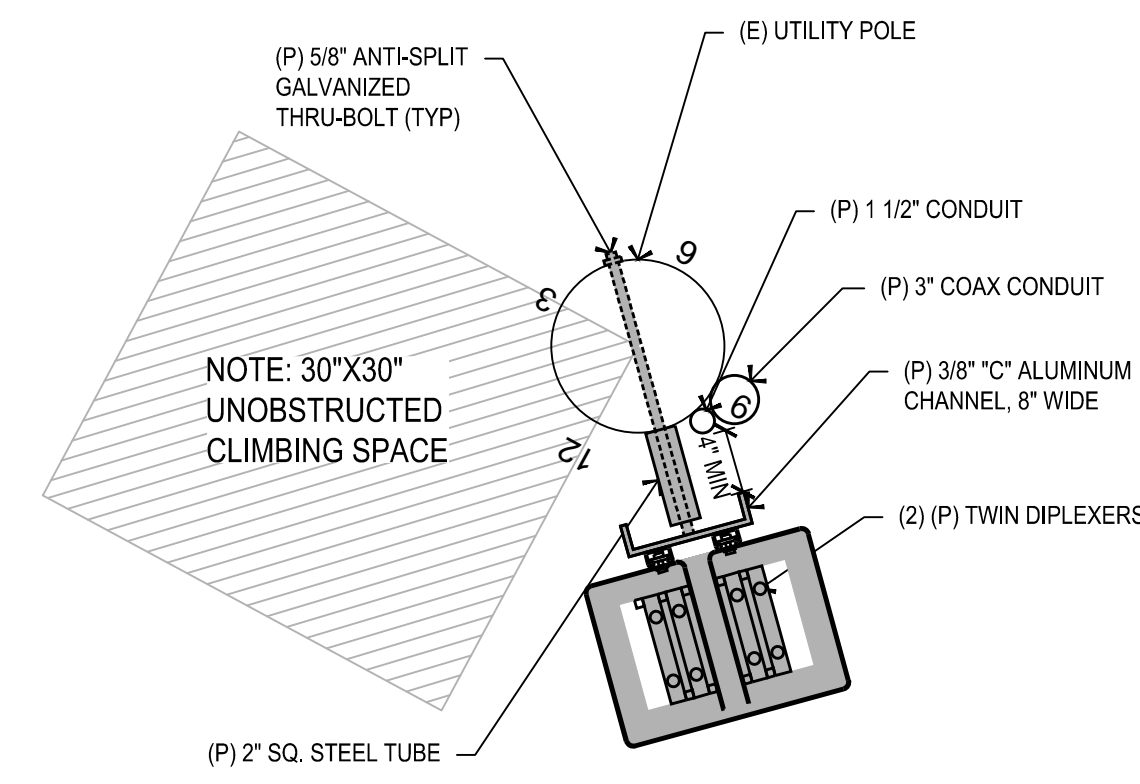

8 SHROUD MOUNTING DETAIL  
1"=1'-0"

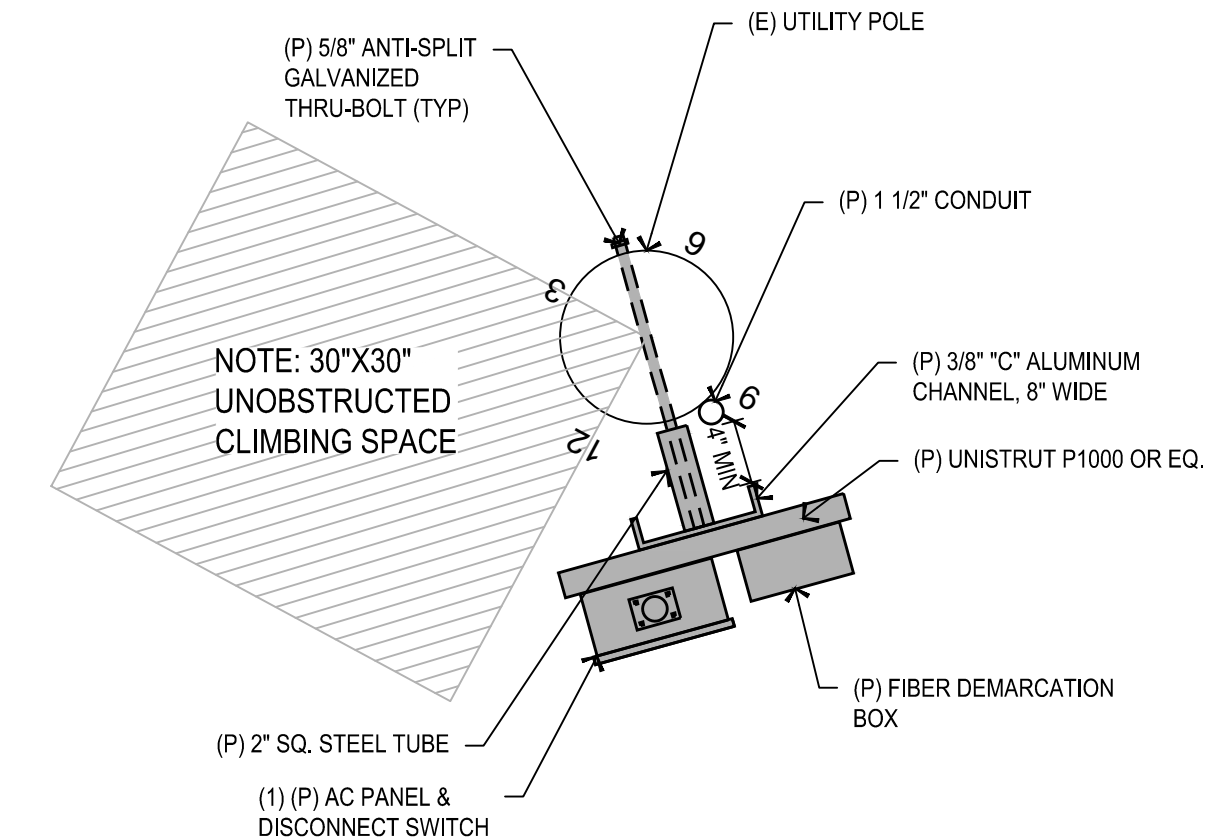

4 LOAD CENTER AND PANEL MOUNTING DETAIL  
1"=1'-0"

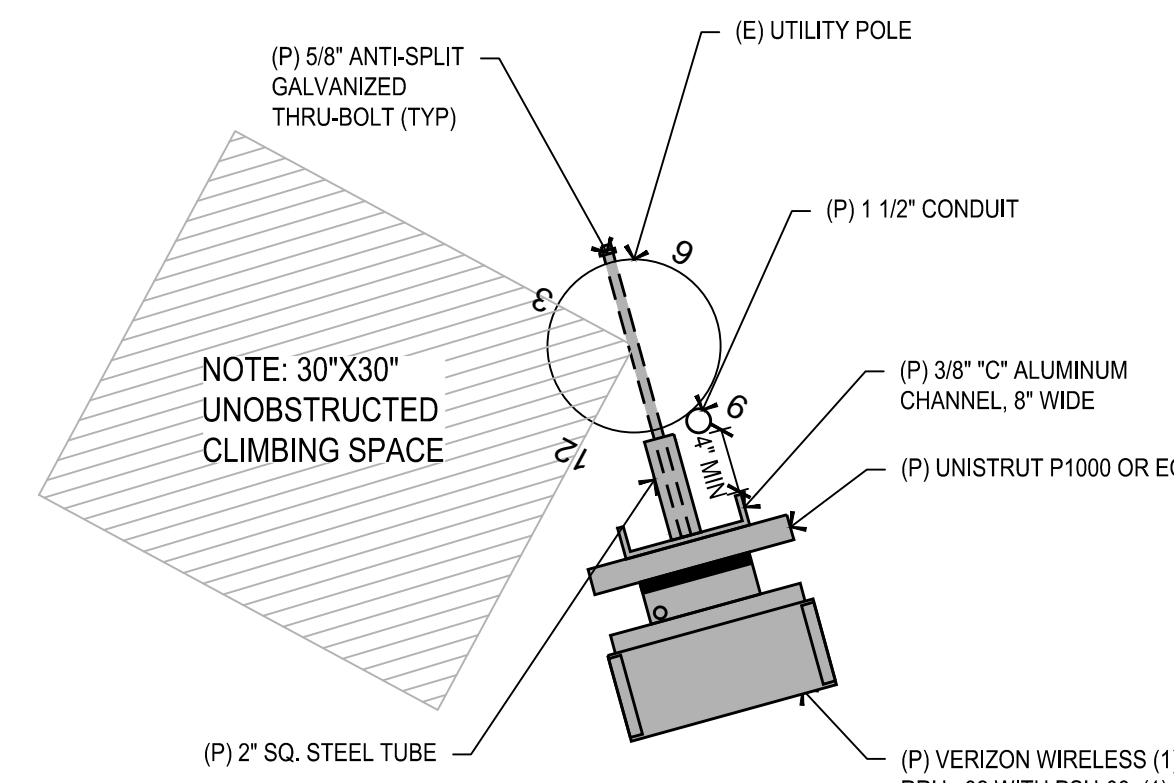

7 RRU MOUNTING DETAIL  
1"=1'-0"

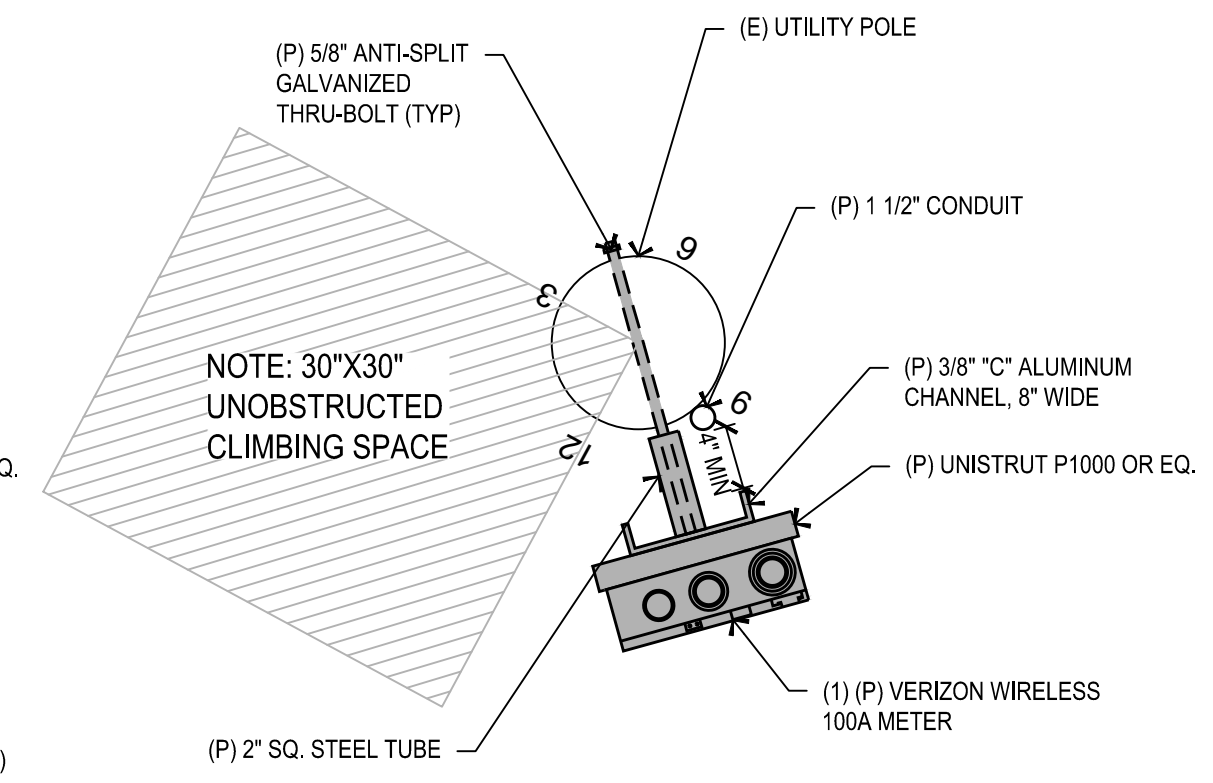

3 POWER METER MOUNTING DETAIL  
1"=1'-0"

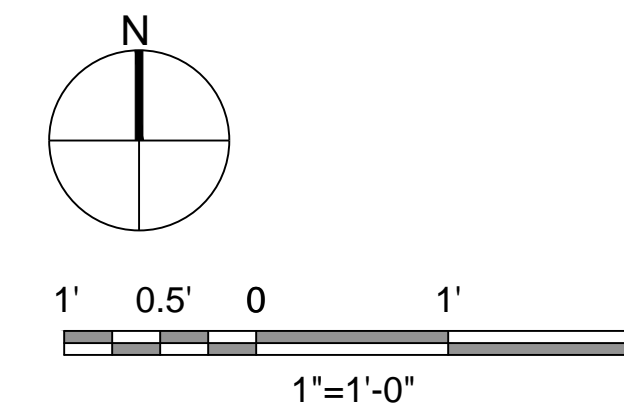
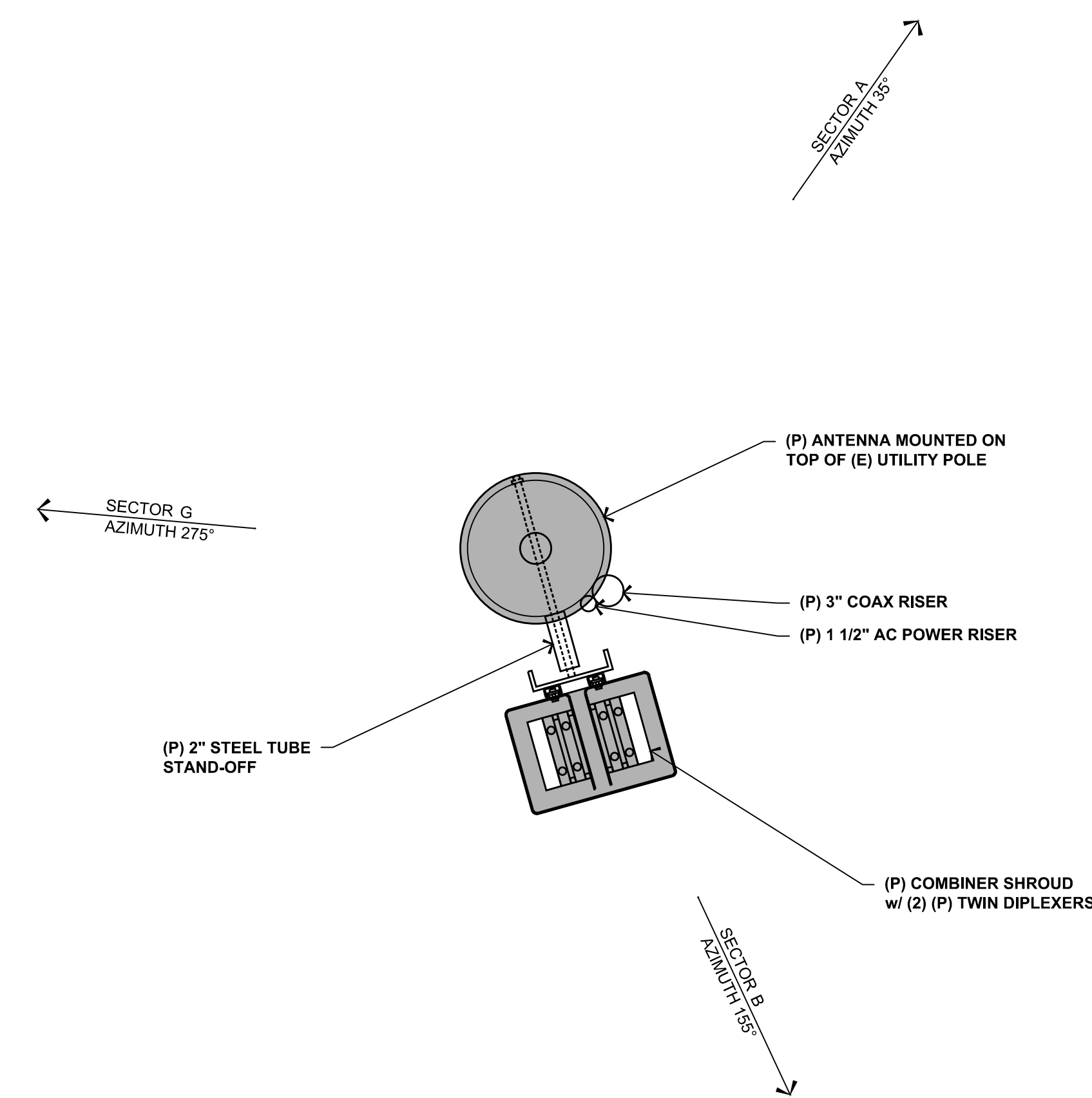

5 ENLARGED ANTENNA PLAN  
1"=1'-0"



2785 MITCHELL DRIVE, SUITE 9  
WALNUT CREEK, CA 94598



modus-corp.com

240 STOCKTON STREET, 3RD FLOOR  
SAN FRANCISCO, CA 94108



borgesarch.com

1478 STONE POINT DRIVE, SUITE 350  
ROSEVILLE CA 95661  
916 782 7200 TEL  
916 773 3037 FAX

REV	DATE	DESCRIPTION
1	02/21/18	90% CD SUBMITTAL
0	10/24/17	90% CD SUBMITTAL

SITE NUMBER:

**BUR\_018**

SITE ADDRESS:  
138 VALDEFLORES DR  
BURLINGAME, CA 94010

STAMP

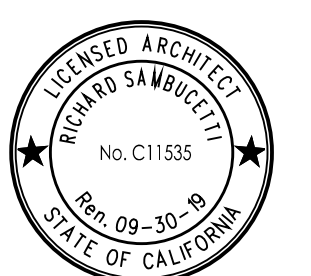

DRAWN BY: D.A.G. PROJECT NO.: T-16519-48

CHECK BY: B.K.W.

SHEET TITLE

ENLARGED SITE  
PLAN & ANTENNA  
PLAN

SHEET NO.

**A-2**



REV	DATE	DESCRIPTION
1	02/21/18	90% CD SUBMITTAL
0	10/24/17	90% CD SUBMITTAL

SITE NUMBER:

**BUR\_018**

SITE ADDRESS:  
138 VALDEFLORES DR  
BURLINGAME, CA 94010

STAMP

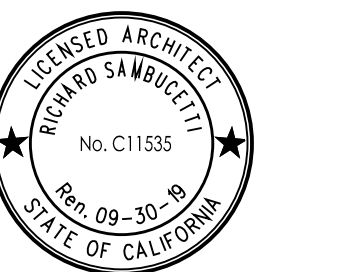

DRAWN BY: D.A.G. PROJECT NO.: T-16519-48

CHECK BY: B.K.W.

SHEET TITLE

ELEVATIONS

SHEET NO.

**A-3**

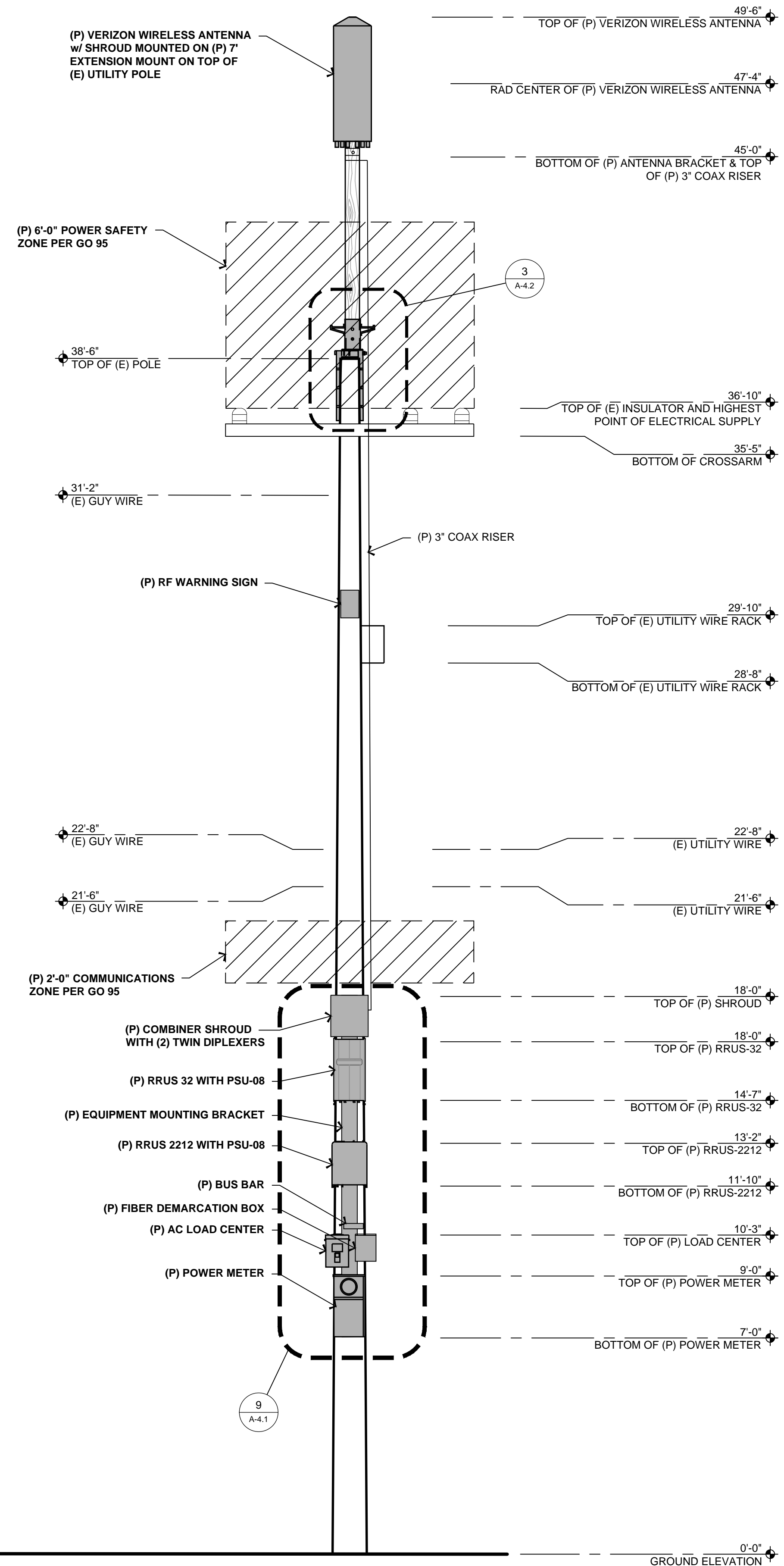
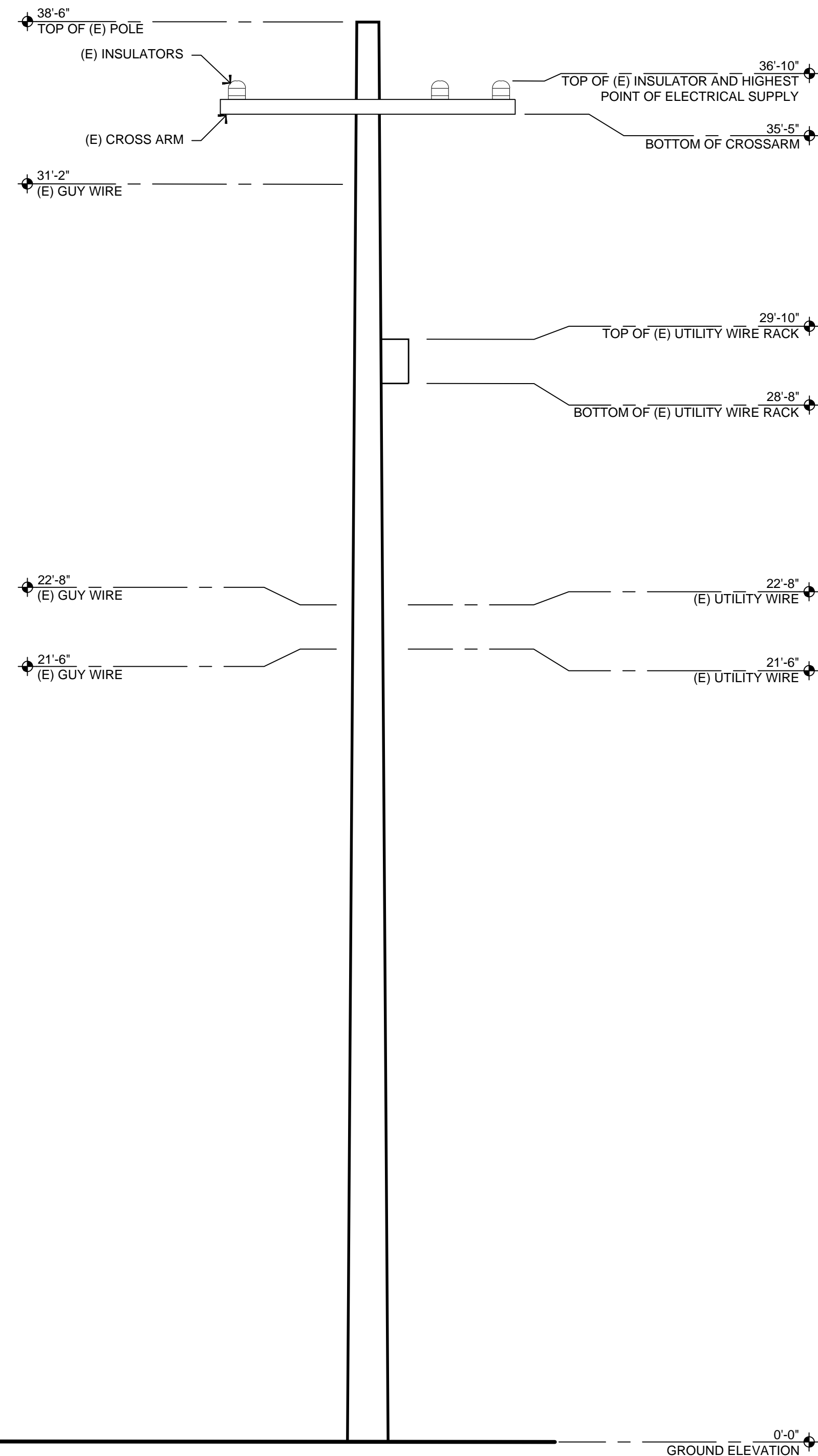

**ERICSSON RRU-32 WITH PSU-08**

MODEL: RRU 32 WITH PSU-08  
 COLOR: WHITE  
 DIMENSIONS: 26.7" TALL X 12.1" WIDE X 6.7" DEEP (INCLUDING SUNSHIELD)  
 WEIGHT: +/- 80.4 LBS. (INCLUDING MOUNTING HARDWARE)

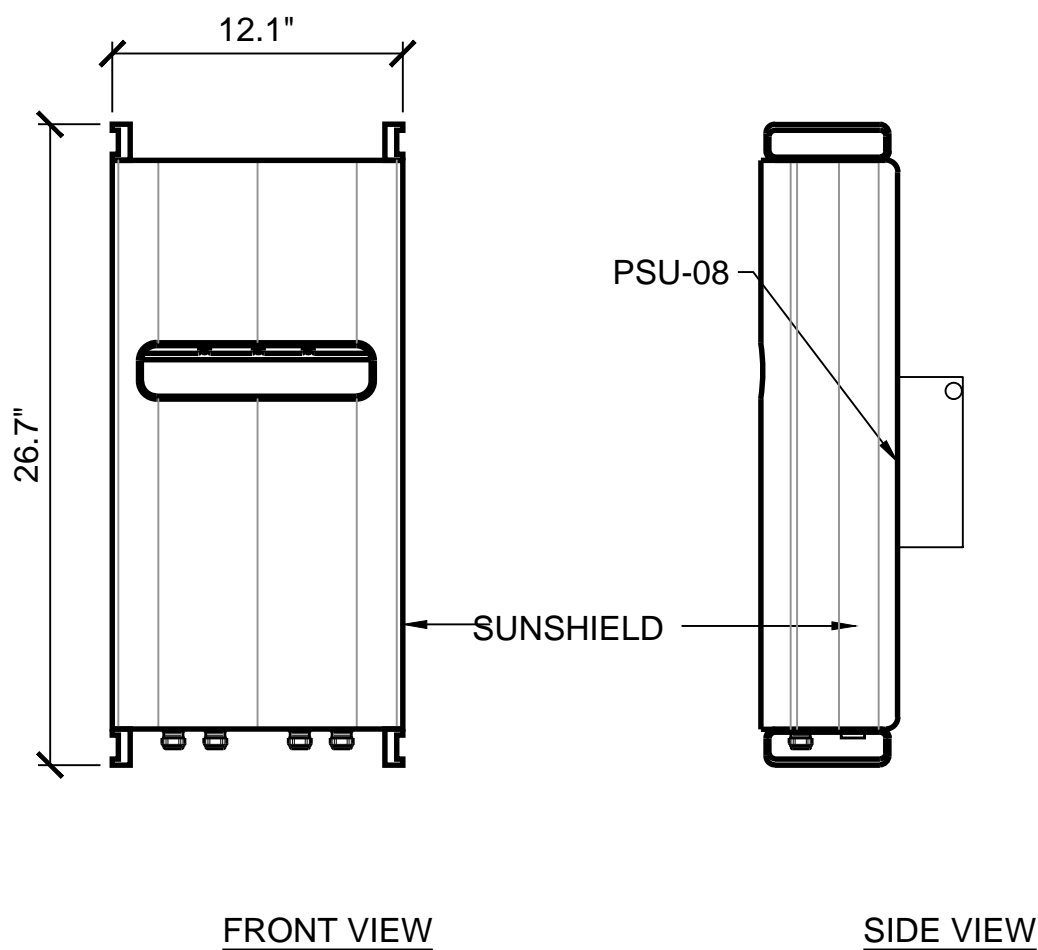
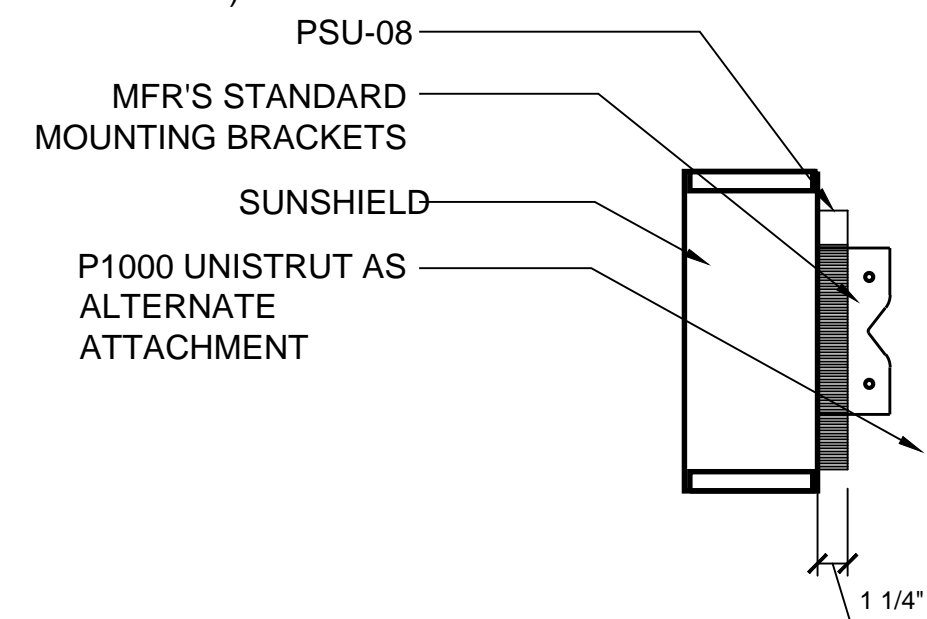

**19 RRU 32 WITH PSU-08 MOUNTING DETAIL**  
 1 1/2" = 1'-0"

**METER MAKE AND MODEL:**  
 MODEL: U21MTBL  
 DIMENSIONS, HxWxD.in: 24" x 12.05" x 4"  
 COLOR: GRAY  
 NEUTRAL CONDUCTOR: 14 AWG-2/0 AWG  
 HUB PROV.: AW  
 SERVICE TYPE: 4  
 VOLTAGE: 600  
 AMPACITY: 100 MAX/ 100 CONT.  
 BRANCH CIRCUITS: NONE  
 CONSTRUCTION TYPE: 3R CONSTRUCTION

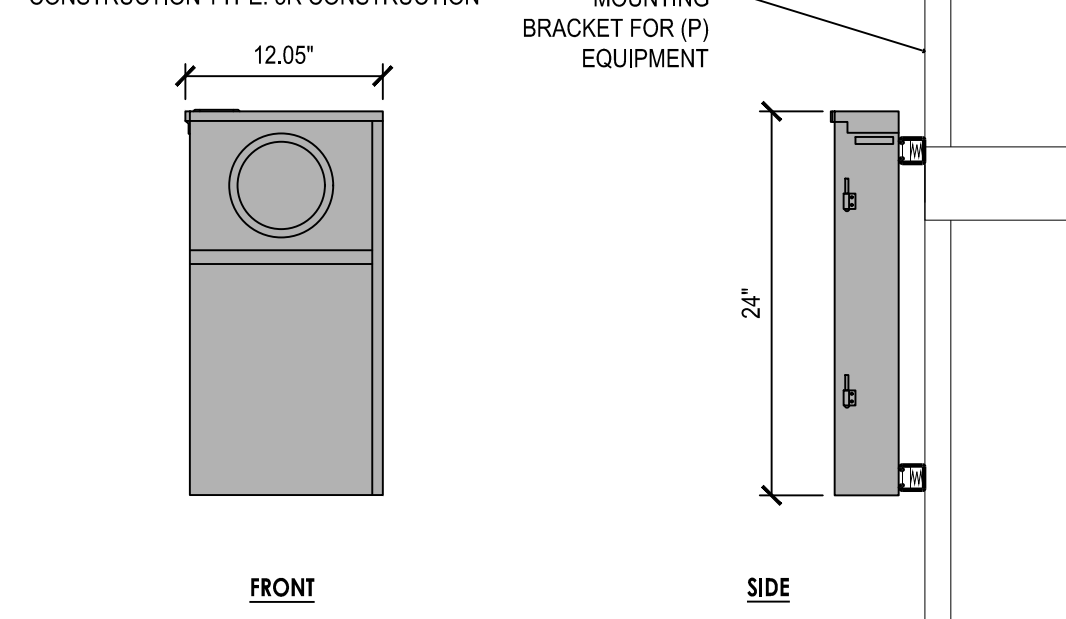

**16 POWER METER DETAIL**  
 1" = 1'-0"

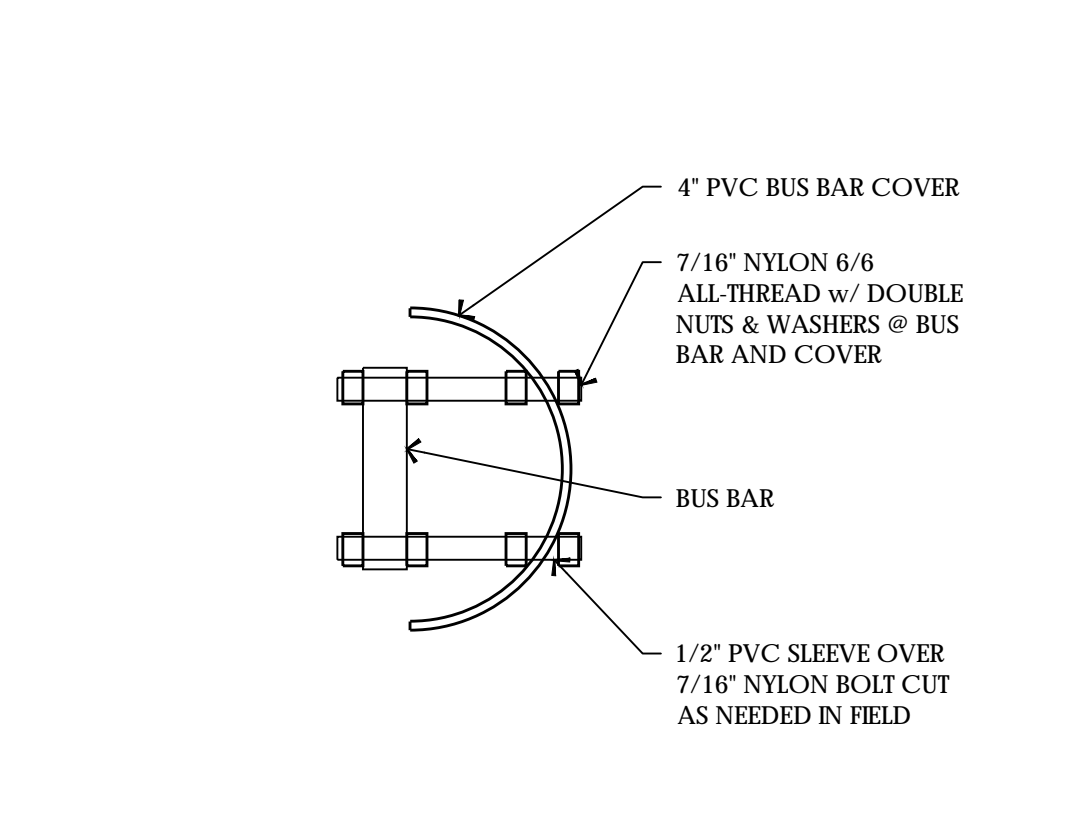

**15 BUS BAR COVER**  
 NOT TO SCALE

**ELEC LOAD CENTER MAKE AND MODEL:**  
 MANUFACTURER: SQUARE D  
 MODEL: QO612L100RB  
 DIMENSIONS, HxWxD.in: 12.64" x 8.9" x 4.27"  
 WEIGHT: 9.7 lbs

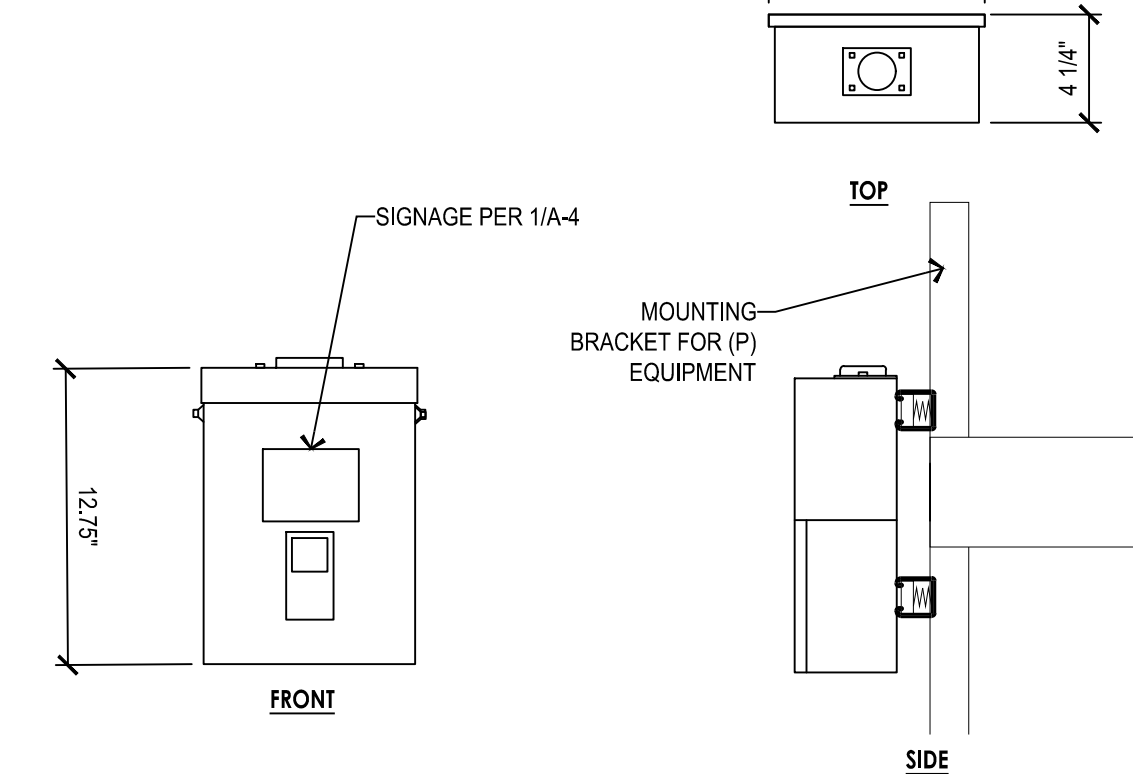

**12 AC ELEC LOAD CENTER DETAIL**  
 1 1/2" = 1'-0"

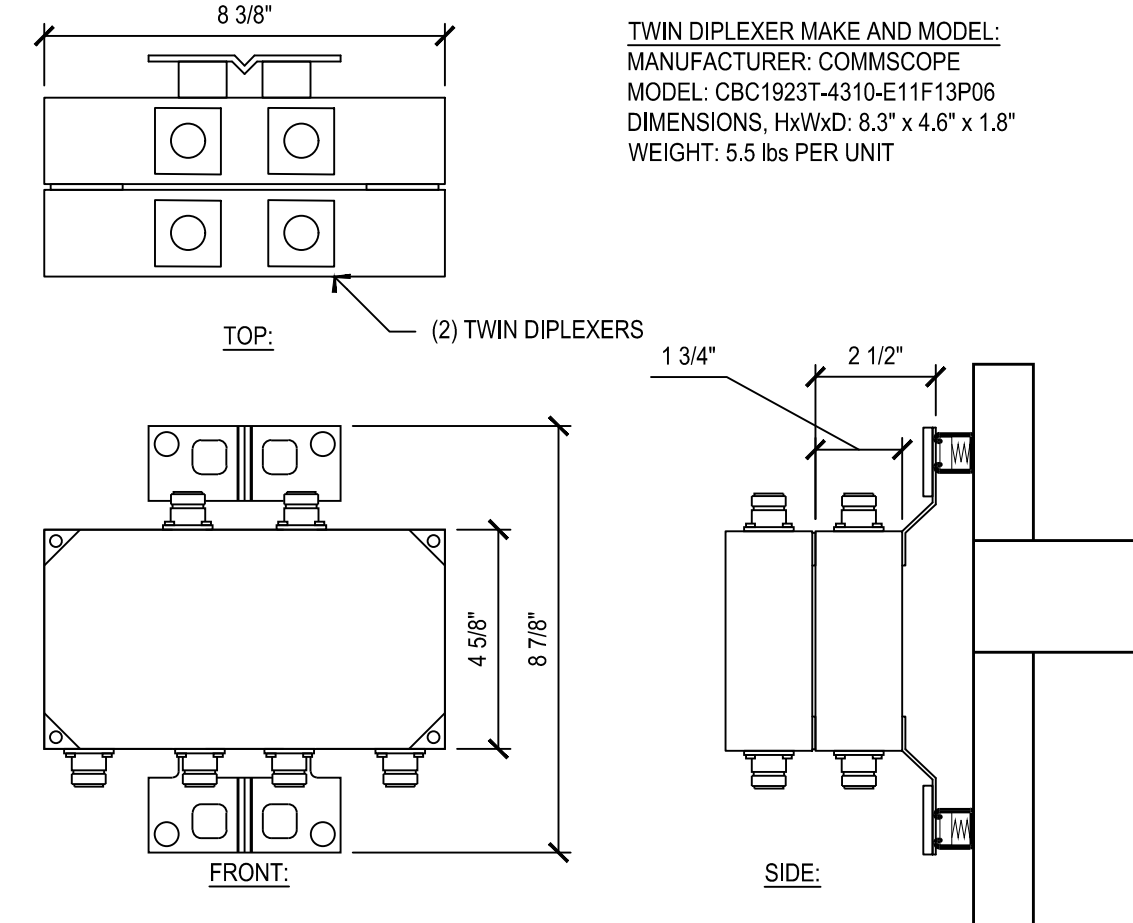

**11 TWIN DIPLEXER DETAIL**  
 3" = 1'-0"

**ERICSSON RRU 2212**

MODEL: RRU 2212  
 COLOR: WHITE  
 DIMENSIONS: 16.54" TALL X 12.6" WIDE X 13.47" DEEP (INCLUDING SUNSHIELD)  
 WEIGHT: +/- 82 LBS. (INCLUDING MOUNTING HARDWARE)

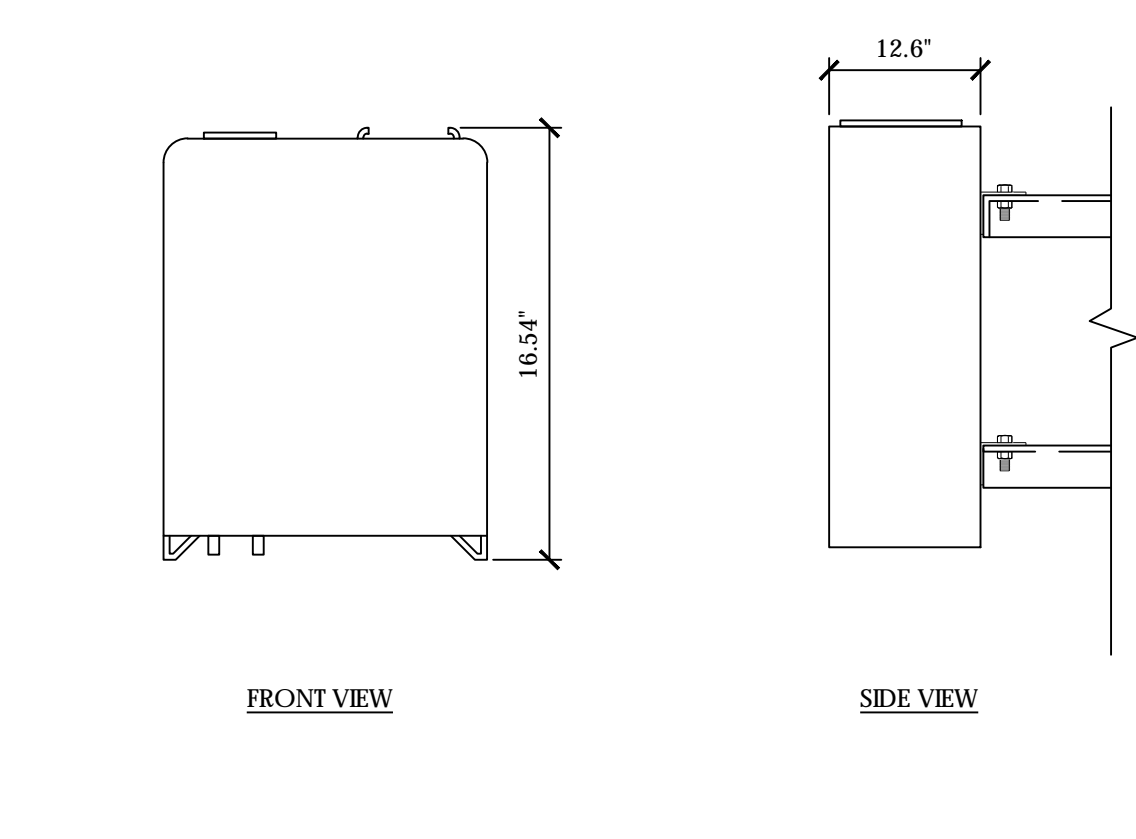
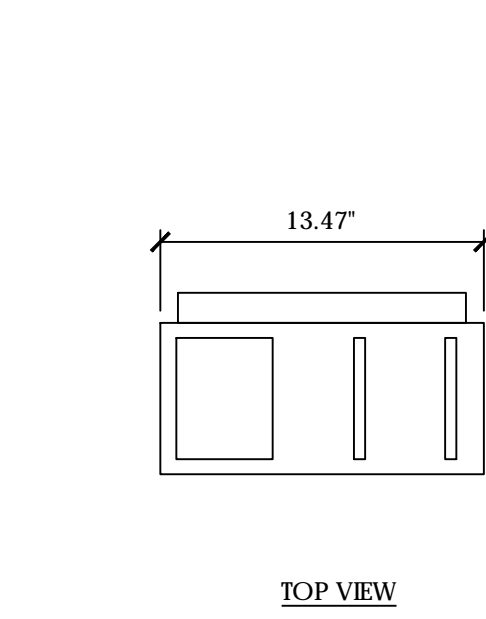

**7 ERICSON RRU 2212**  
 1 1/2" = 1'-0"

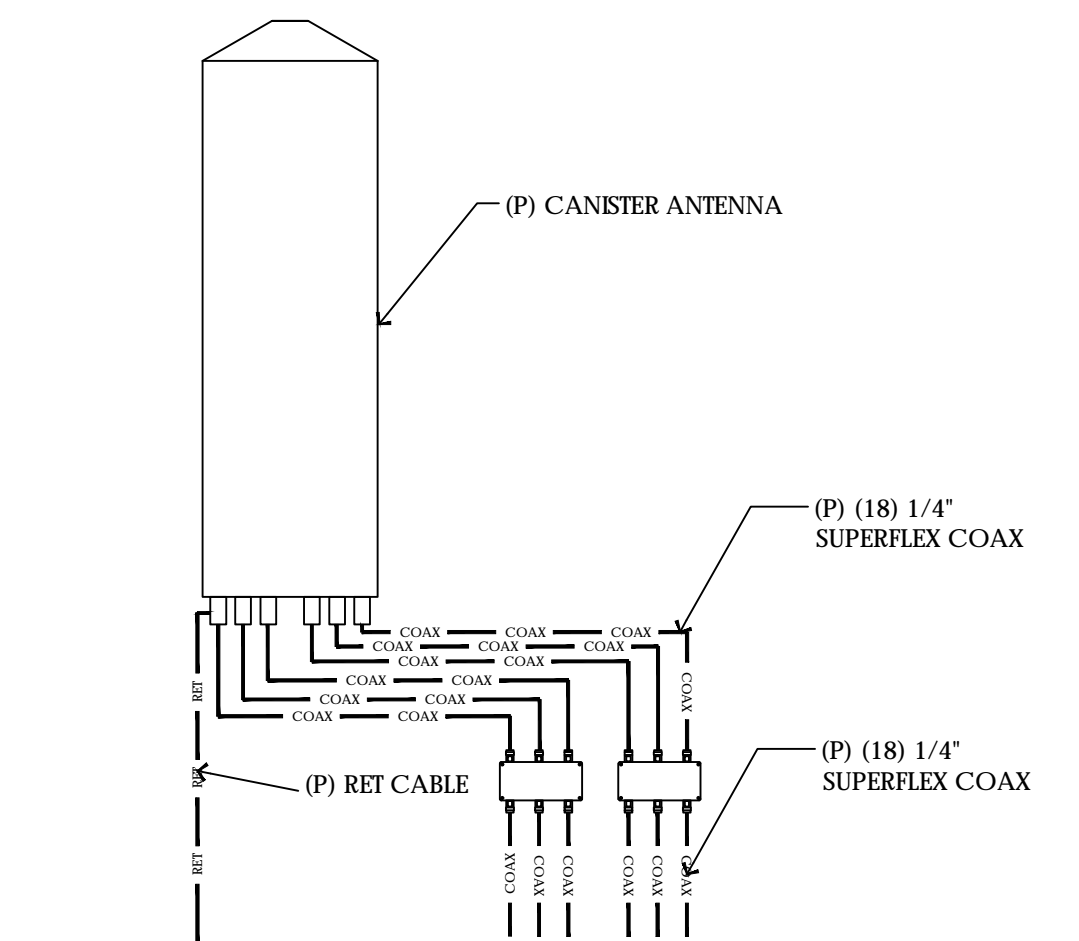

**4 WIRE DIAGRAM**  
 3/4" = 1'-0"

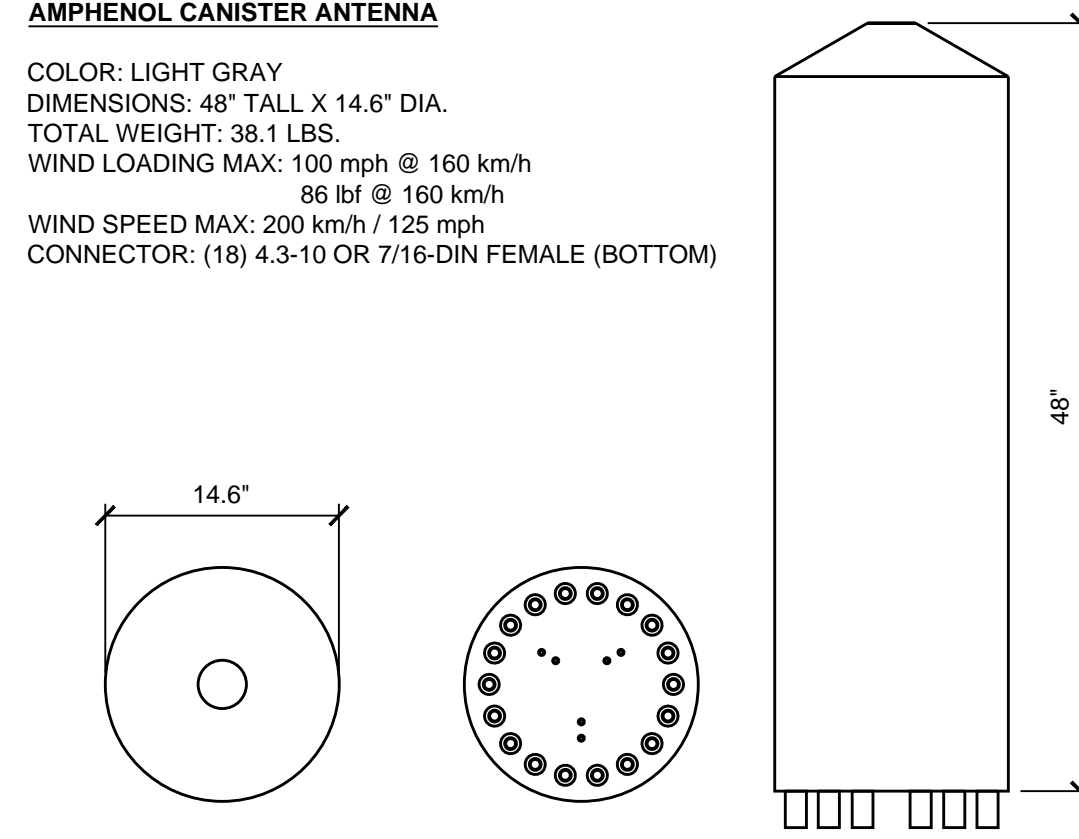

**3 AMPHINOL CANISTER ANTENNA**  
 1" = 1'-0"

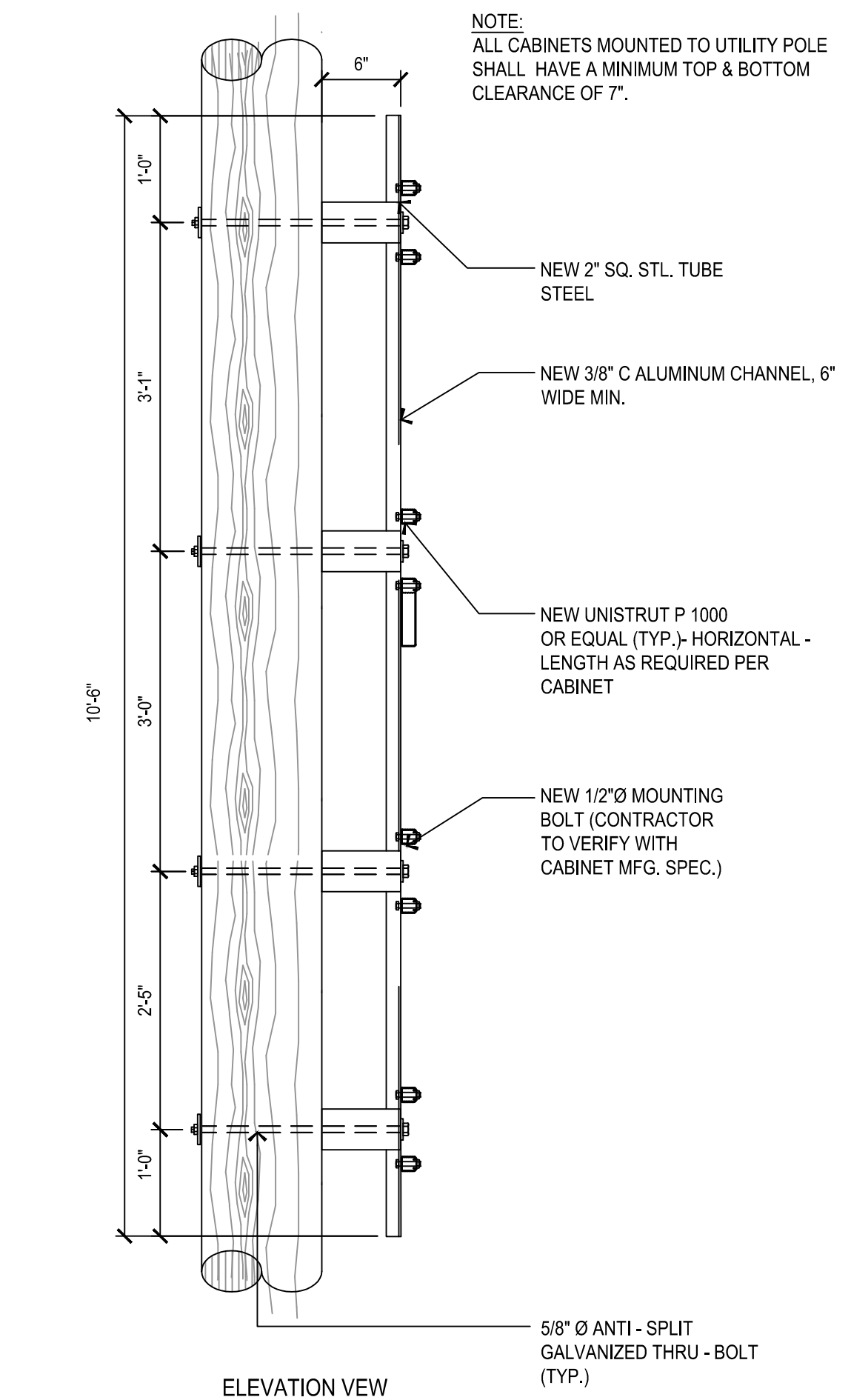

**17 EQUIPMENT MOUNTING DETAIL**  
 3/4" = 1'-0"

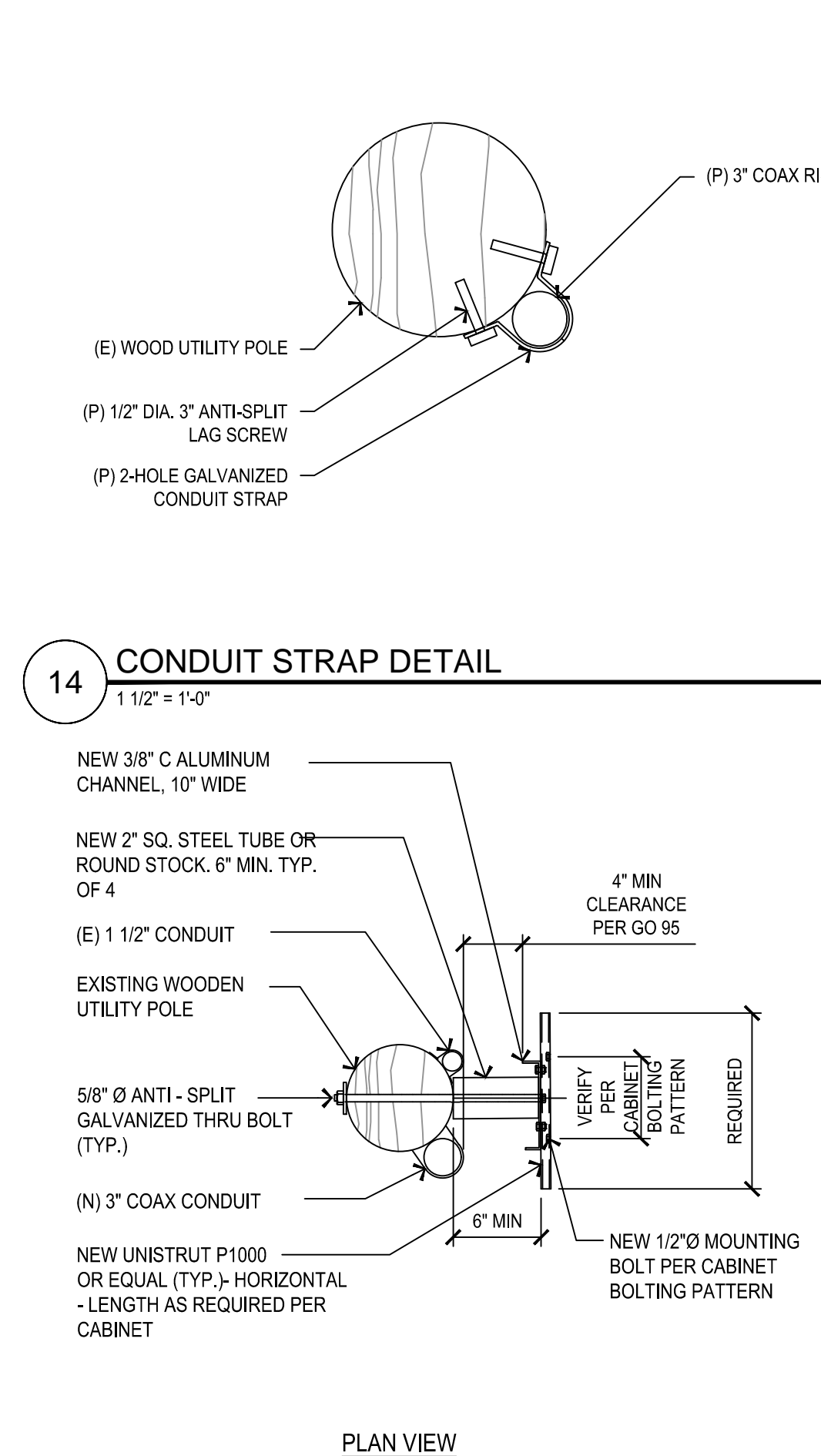

**14 CONDUIT STRAP DETAIL**  
 1 1/2" = 1'-0"

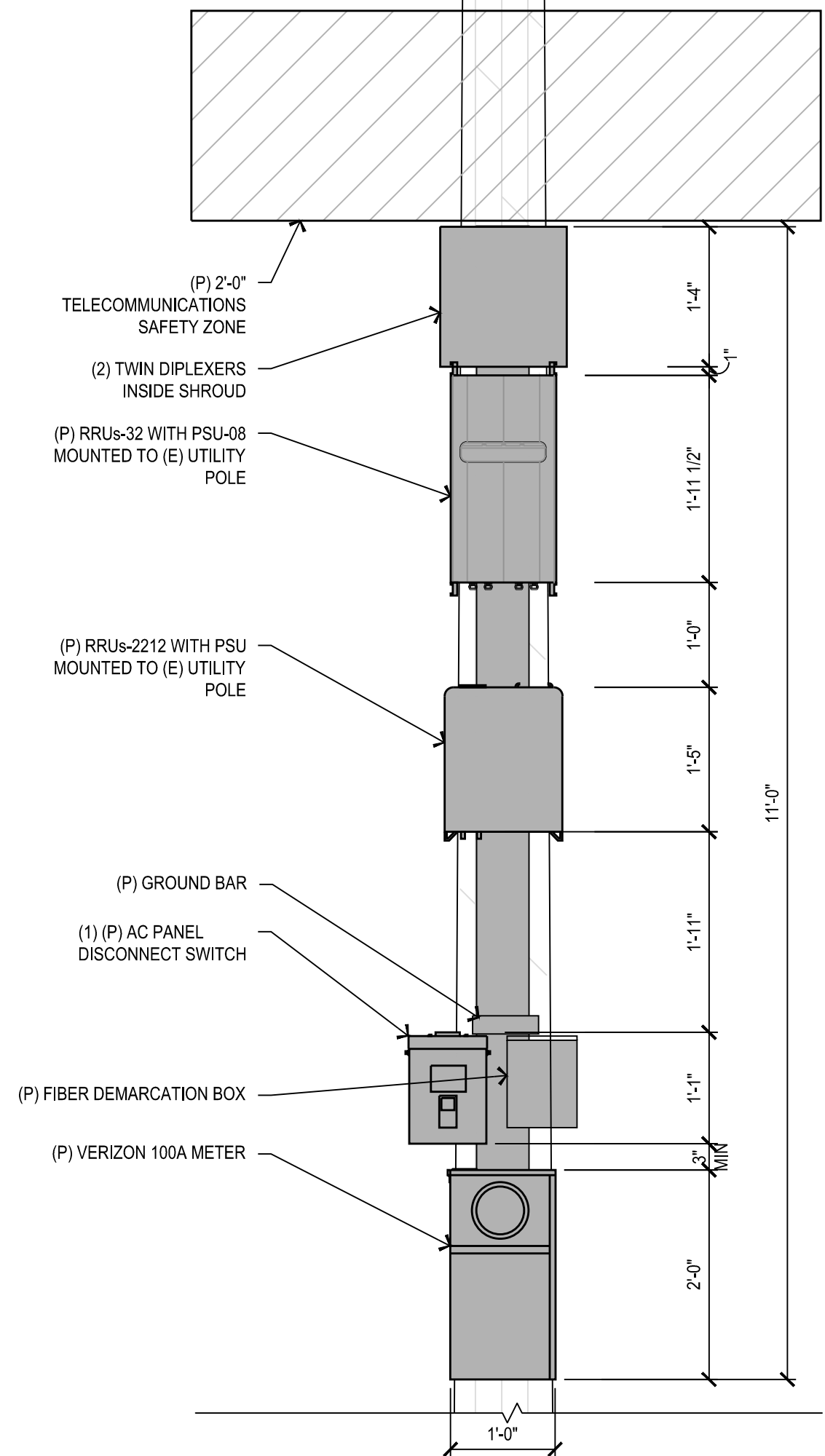

**9 ANTENNA EQUIPMENT FRONT ELEVATION**  
 3/4" = 1'-0"

**NOTE:**  
 SIGN BACKGROUND COLOR TO MATCH (E) POLE  
 ALL TEXT AND SYMBOLS TO BE WHITE

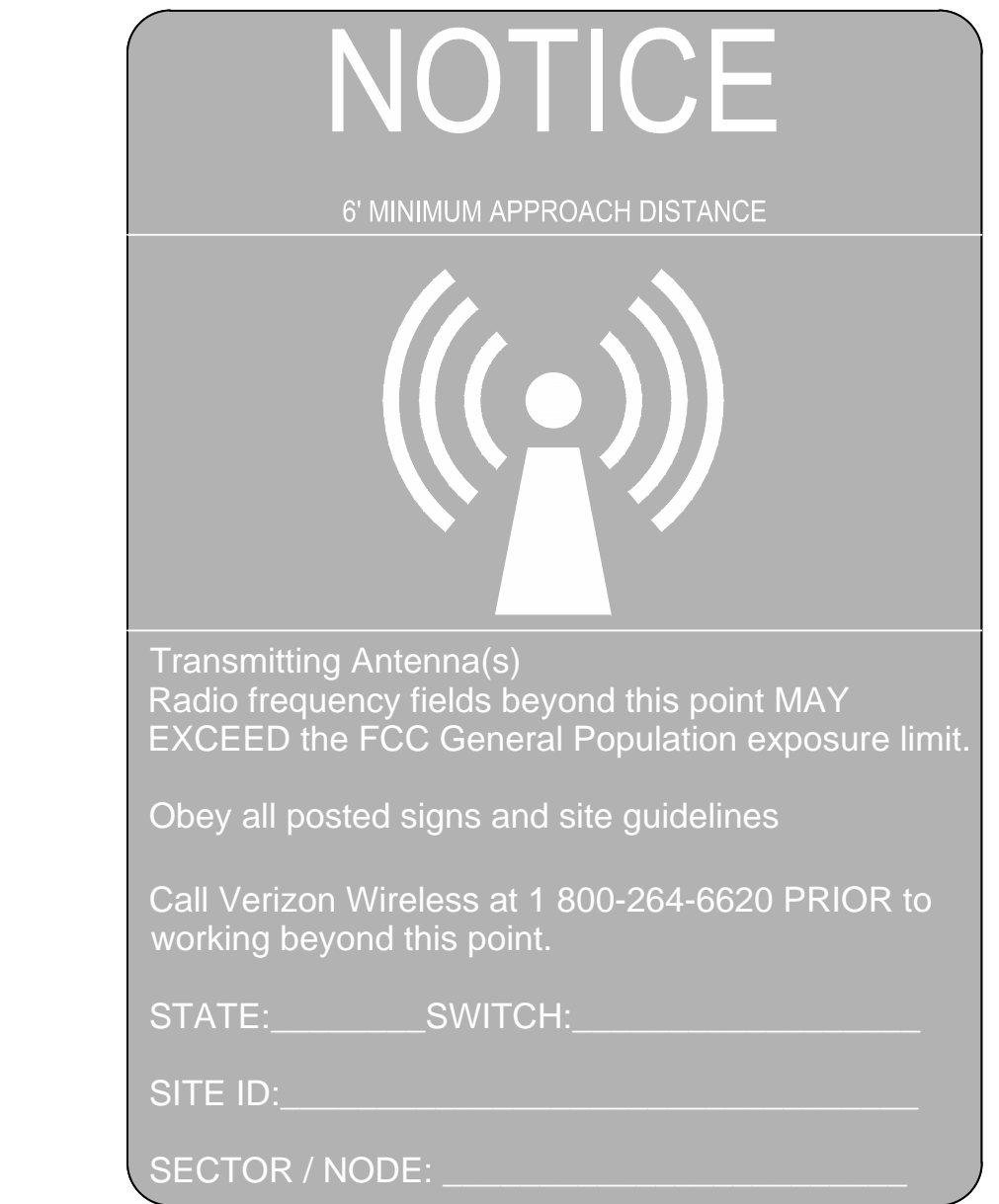

**5 NOTICE SIGNAGE**  
 1" = 1'-0"

**NOTE:**  
 1. INSIDE AND OUTSIDE PANEL DOOR SHOWING SHUT-DOWN PROTOCOL ON 3"X4" LABEL  
 2. SITE ID WIL LBE SWITCH #, SITE #, & SITE NAME  
 3. SIGN PROVIDED BY GC MOUNTED TO OUTSIDE OF SERVICE DISCONNECT

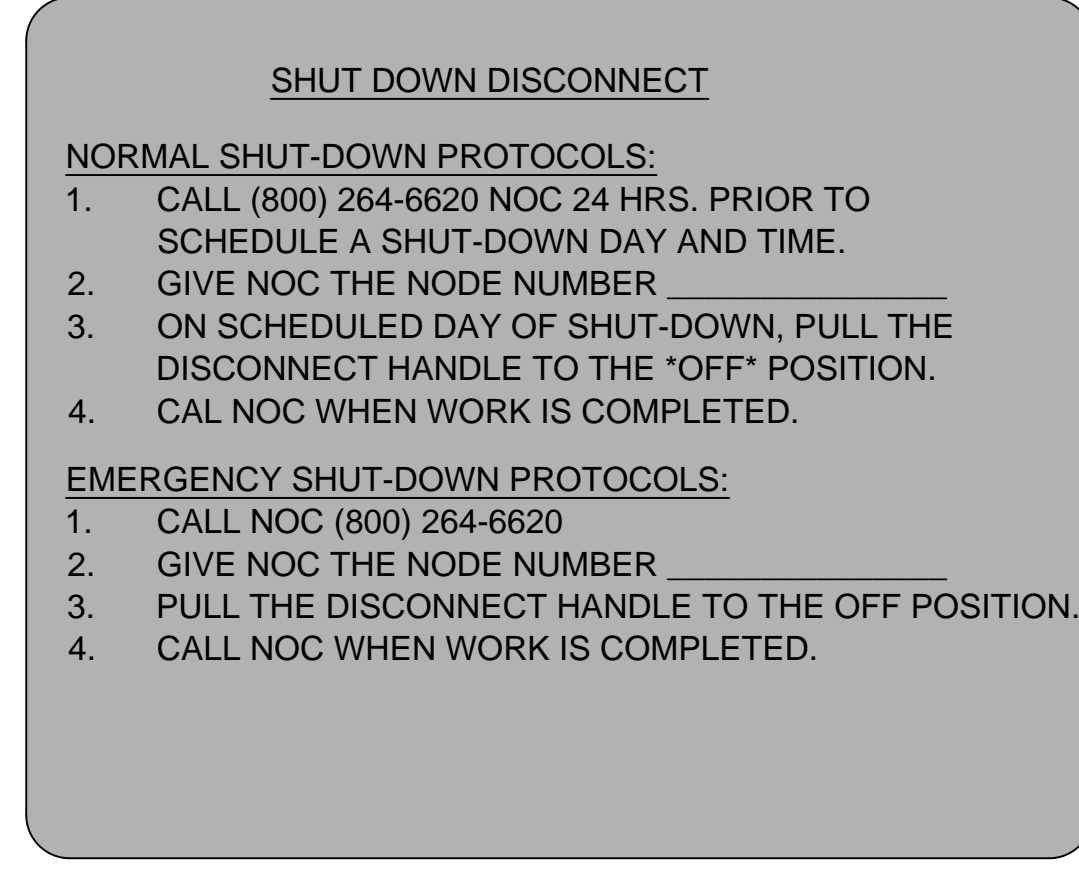

**1 SHUT DOWN PROTOCOL SIGNAGE**  
 1" = 1'-0"



2785 MITCHELL DRIVE, SUITE 9  
 WALNUT CREEK, CA 94598



modus-corp.com

240 STOCKTON STREET, 3RD FLOOR  
 SAN FRANCISCO, CA 94108



borgesarch.com

1478 STONE POINT DRIVE, SUITE 350  
 ROSEVILLE CA 95661  
 916 782 7200 TEL  
 916 773 3037 FAX

REV	DATE	DESCRIPTION
1	02/21/18	90% CD SUBMITTAL
0	10/24/17	90% CD SUBMITTAL

**SITE NUMBER:**

**BUR\_018**

**SITE ADDRESS:**  
 138 VALDEFLORES DR  
 BURLINGAME, CA 94010

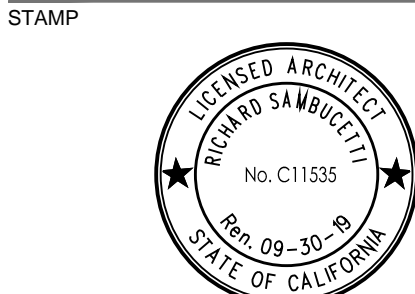

DRAWN BY: D.A.G. PROJECT NO.: T-16519-48  
 CHECK BY: B.K.W.  
 SHEET TITLE

**DETAILS**

SHEET NO.

**A-4.1**

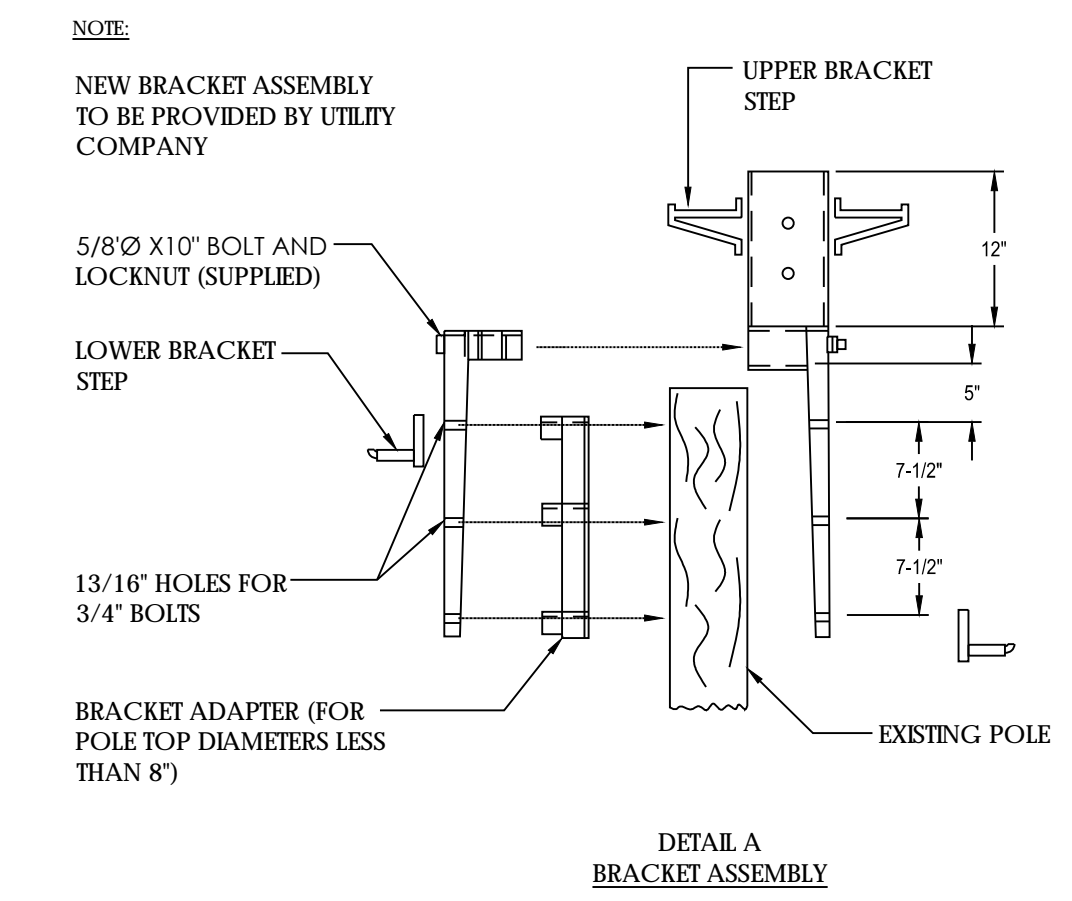
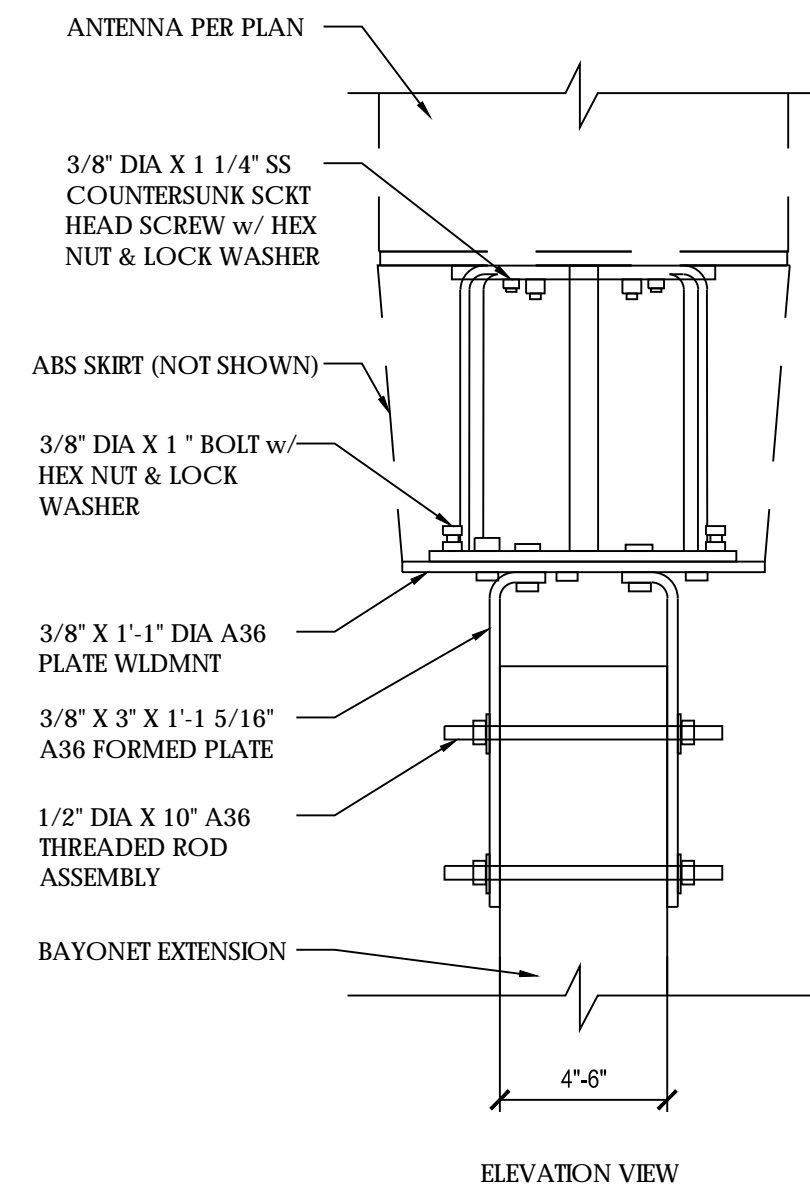

**ARIA NID-12 FIBER DEMARCATION BOX:**  
 MANUFACTURER: ARIA  
 MODEL: NID-12  
 DIMENSIONS (HxWxD): 8.54" x 10" x 2.88"

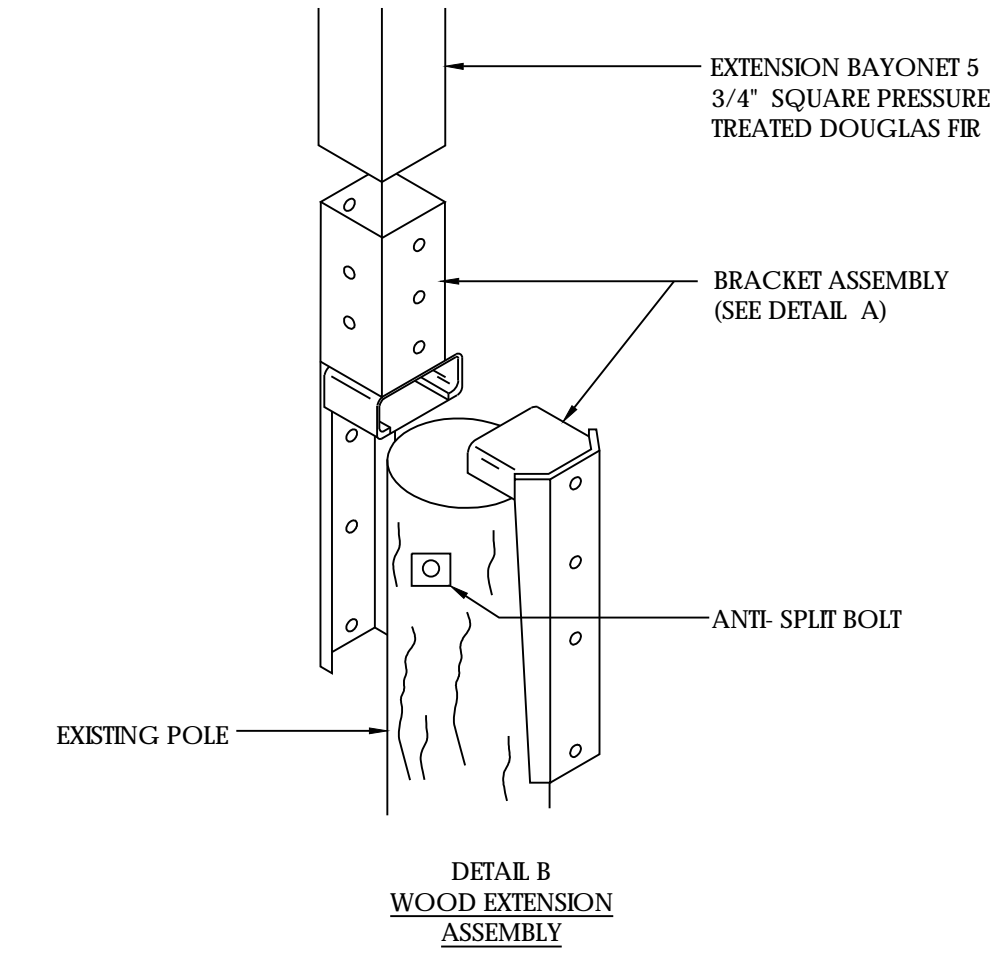
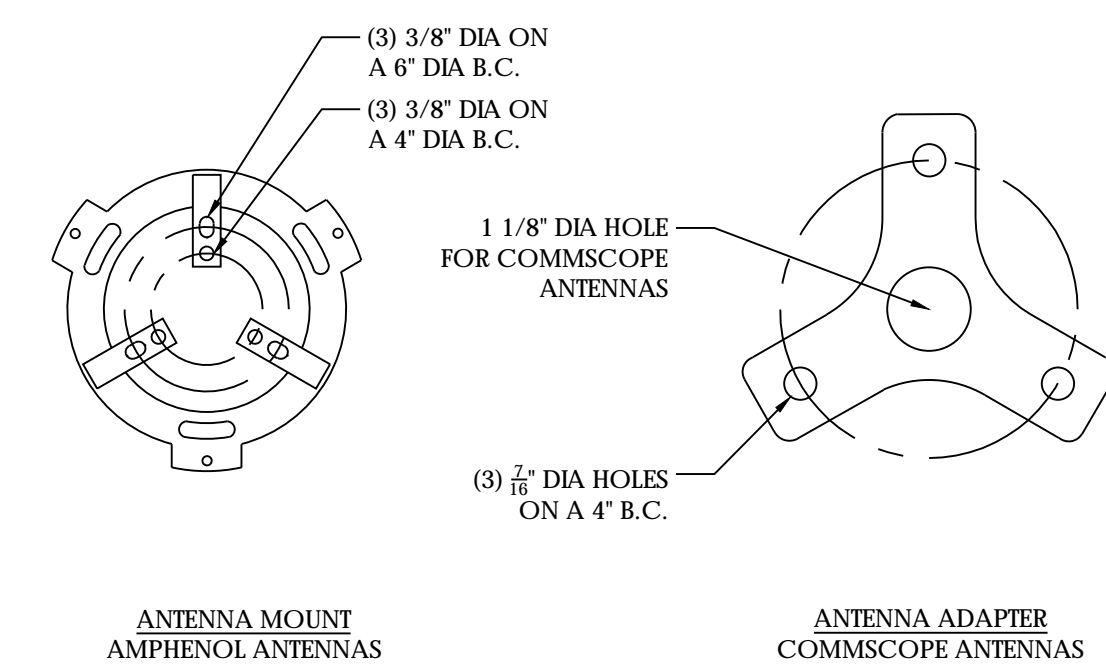
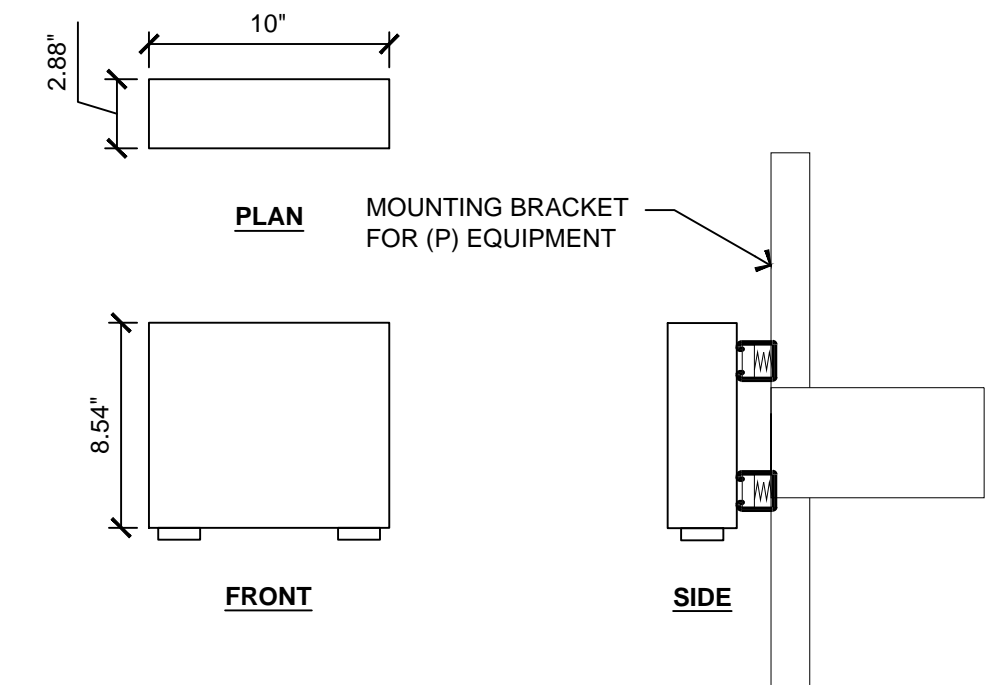

11 ARIA NID-12 FIBER DEMARCATION BOX  
 1 1/2" = 1'-0" rename me to this view "dwg" name

7 TOP MOUNT ANTENNA BRACKET  
 NOT TO SCALE

3 WOOD POLE EXTENSION  
 3/4" = 1'-0"

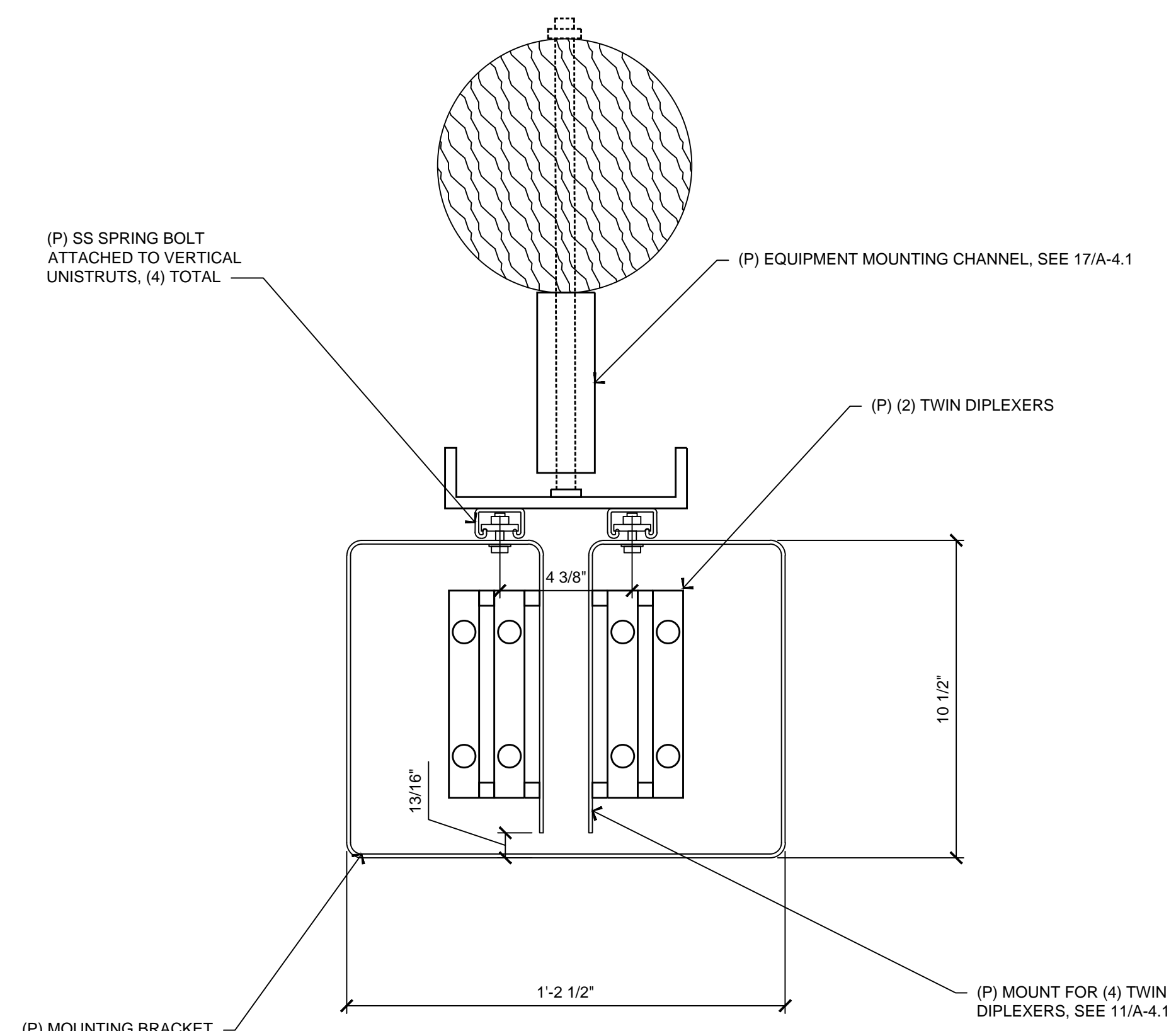
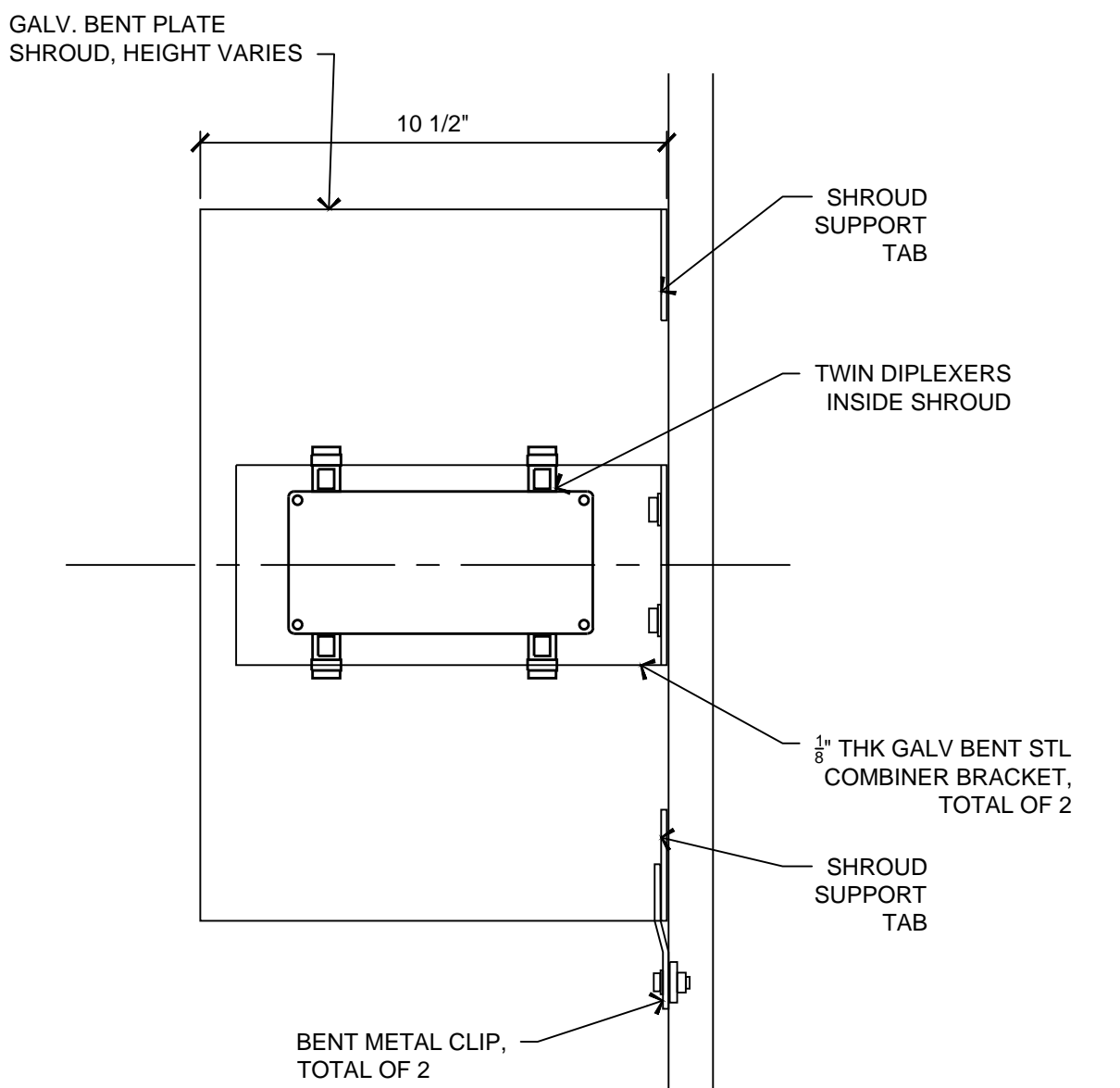
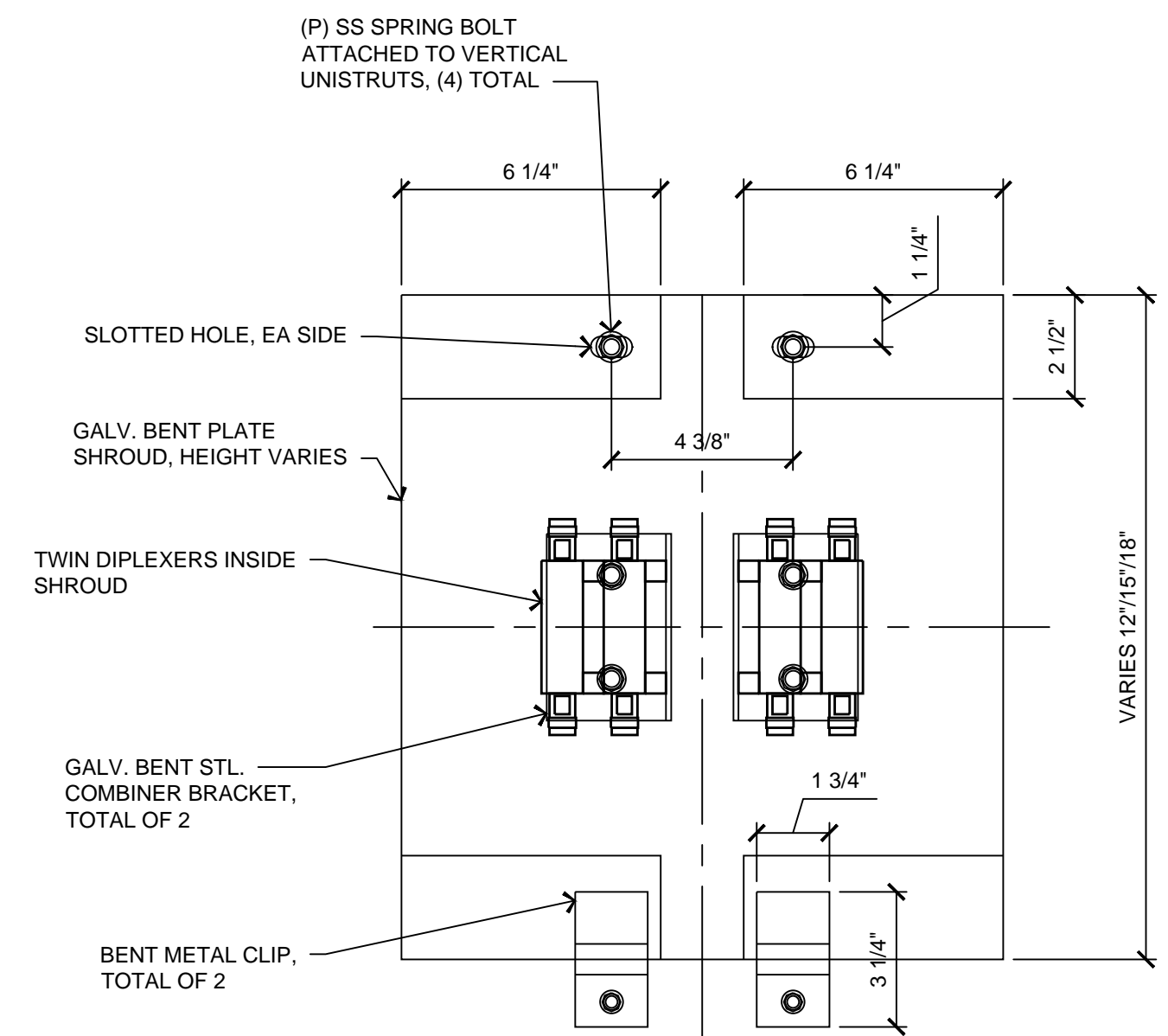

13 COMBINER SHROUD DETAIL  
 3" = 1'-0"



2785 MITCHELL DRIVE, SUITE 9  
 WALNUT CREEK, CA 94598



modus-corp.com

240 STOCKTON STREET, 3RD FLOOR  
 SAN FRANCISCO, CA 94108



borgesarch.com

1478 STONE POINT DRIVE, SUITE 350  
 ROSEVILLE CA 95661  
 916 782 7200 TEL  
 916 773 3037 FAX

REV	DATE	DESCRIPTION
1	02/21/18	90% CD SUBMITTAL
0	10/24/17	90% CD SUBMITTAL

SITE NUMBER:

**BUR\_018**

SITE ADDRESS:  
 138 VALDEFLORES DR  
 BURLINGAME, CA 94010

STAMP

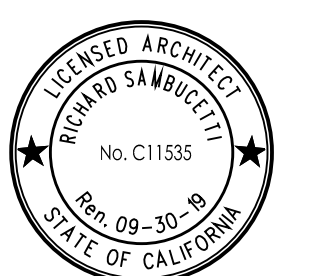

DRAWN BY: D.A.G. PROJECT NO.: T-16519-48

CHECK BY: B.K.W.

SHEET TITLE

DETAILS

SHEET NO.

**A-4.2**

**ELECTRICAL NOTES**

**GENERAL REQUIREMENTS:**

- ALL WORK AND MATERIALS SHALL BE IN ACCORDANCE WITH THE LATEST RULES AND REGULATIONS OF THE NATIONAL ELECTRICAL CODE AND ALL STATE AND LOCAL CODES. NOTHING IN THESE PLANS OR SPECIFICATIONS SHALL BE CONSTRUED AS TO PERMIT WORK NOT CONFORMING TO THE MOST STRINGENT OF THESE CODES. SHOULD CHANGES BE NECESSARY IN THE DRAWINGS OR SPECIFICATIONS TO MAKE THE WORK COMPLY WITH THESE REQUIREMENTS, THE CONTRACTOR SHALL IMMEDIATELY NOTIFY THE ARCHITECT IN WRITING AND CEASE WORK ON PARTS OF THE CONTRACT WHICH ARE AFFECTED.
- THE CONTRACTOR SHALL MAKE A SITE VISIT PRIOR TO BIDDING AND CONSTRUCTION TO VERIFY ALL EXISTING CONDITIONS AND SHALL NOTIFY ARCHITECT IMMEDIATELY UPON DISCOVERY OF ANY DISCREPANCIES. THE CONTRACTOR ASSUMES ALL LIABILITY FOR FAILURE TO COMPLY WITH THIS PROVISION.
- THE EXTENT OF THE WORK IS INDICATED BY THE DRAWINGS, SCHEDULES, AND SPECIFICATIONS AND IS SUBJECT TO THE TERMS AND CONDITIONS OF THE CONTRACT. THE WORK SHALL CONSIST OF FURNISHING ALL LABOR, EQUIPMENT, MATERIALS, AND SUPPLIES NECESSARY FOR A COMPLETE AND OPERATIONAL ELECTRICAL SYSTEM. THE WORK SHALL ALSO INCLUDE THE COMPLETION OF ALL ELECTRICAL WORK NOT MENTIONED OR SHOWN WHICH IS NECESSARY FOR SUCCESSFUL OPERATION OF ALL SYSTEMS.
- THE CONTRACTOR SHALL PREPARE A BID FOR A COMPLETE AND OPERATIONAL SYSTEM, WHICH INCLUDES THE COST FOR MATERIAL AND LABOR.
- WORKMANSHIP AND NEAT APPEARANCE SHALL BE AS IMPORTANT AS THE OPERATION. DEFECTIVE OR DAMAGED MATERIALS SHALL BE REPLACED OR REPAIRED PRIOR TO FINAL ACCEPTANCE IN A MANNER ACCEPTABLE TO OWNER AND ENGINEER.
- COMPLETE THE ENTIRE INSTALLATION AS SOON AS THE PROGRESS OF THE WORK WILL PERMIT. ARRANGE ANY OUTAGE OF SERVICE WITH THE OWNER AND BUILDING MANAGER IN ADVANCE. MINIMIZE DOWNTIME ON THE BUILDING ELECTRICAL SYSTEM.
- THE ENTIRE ELECTRICAL SYSTEM INSTALLED UNDER THIS CONTRACT SHALL BE DELIVERED IN PROPER WORKING ORDER. REPLACE, WITHOUT ADDITIONAL COST TO THE OWNER, ANY DEFECTIVE MATERIAL AND EQUIPMENT WITHIN ONE YEAR FROM THE DATE OF FINAL ACCEPTANCE.
- ANY ERROR, OMISSION OR DESIGN DISCREPANCY ON THE DRAWINGS SHALL BE BROUGHT TO THE ATTENTION OF THE ENGINEER FOR CLARIFICATION OR CORRECTION BEFORE CONSTRUCTION.
- "PROVIDE" INDICATES THAT ALL ITEMS ARE TO BE FURNISHED, INSTALLED AND CONNECTED IN PLACE.
- CONTRACTOR SHALL SECURE ALL NECESSARY BUILDING PERMITS AND PAY ALL REQUIRED FEES.

**EQUIPMENT LOCATION:**

- THE DRAWINGS INDICATE DIAGRAMMATICALLY THE DESIRED LOCATIONS OR ARRANGEMENTS OF CONDUIT RUNS, OUTLETS, EQUIPMENT, ETC., AND ARE TO BE FOLLOWED AS CLOSELY AS POSSIBLE. PROPER JUDGEMENT MUST BE EXERCISED IN EXECUTING THE WORK SO AS TO SECURE THE BEST POSSIBLE INSTALLATION IN THE AVAILABLE SPACE LIMITATIONS OR INTERFERENCE OF STRUCTURE CONDITIONS ENCOUNTERED.
- IN THE EVENT CHANGES IN THE INDICATED LOCATIONS OR ARRANGEMENTS ARE NECESSARY, DUE TO FIELD CONDITIONS IN THE BUILDING CONSTRUCTION OR REARRANGEMENT OF FURNISHINGS OR EQUIPMENT, SUCH CHANGES SHALL BE MADE WITHOUT COST, PROVIDING THE CHANGE IS ORDERED BEFORE THE CONDUIT RUNS, ETC., AND WORK DIRECTLY CONNECTED TO THE SAME IS INSTALLED AND NO EXTRA MATERIALS ARE REQUIRED.
- LIGHTING FIXTURES ARE SHOWN IN THEIR APPROXIMATE LOCATIONS ONLY. COORDINATE THE FIXTURE LOCATION WITH MECHANICAL EQUIPMENT TO AVOID INTERFERENCE.
- COORDINATE THE WORK OF THIS SECTION WITH THAT OF ALL OTHER TRADES, WHERE CONFLICTS OCCUR. CONSULT WITH THE RESPECTIVE CONTRACTOR AND COME TO AGREEMENT AS TO CHANGES NECESSARY. OBTAIN WRITTEN ACCEPTANCE FROM ENGINEER FOR THE PROPOSED CHANGES BEFORE PROCEEDING.

**SHOP DRAWINGS:**

- N/A UNLESS NOTED OTHERWISE.

**SUBSTITUTIONS:**

- NO SUBSTITUTIONS ARE ALLOWED

**TESTS:**

- BEFORE FINAL ACCEPTANCE OF WORK, THE CONTRACTOR SHALL INSURE THAT ALL EQUIPMENT, SYSTEMS, FIXTURES, ETC., ARE WORKING SATISFACTORILY AND TO THE INTENT OF THE DRAWINGS.

**PERMITS:**

- THE CONTRACTOR SHALL BE RESPONSIBLE FOR TAKING OUT AND PAYING FOR ALL REQUIRED PERMITS, INSPECTION AND EXAMINATION WITHOUT ADDITIONAL EXPENSE TO THE OWNER.

**GROUNDING:**

- THE CONTRACTOR SHALL PROVIDE A COMPLETE, AND APPROVED GROUNDING SYSTEM INCLUDING ELECTRODES, ELECTRODE CONDUCTOR, BONDING CONDUCTORS, AND EQUIPMENT CONDUCTORS AS REQUIRED BY ARTICLE 250 OF THE NATIONAL ELECTRICAL CODE.
- CONDUITS CONNECTED TO EQUIPMENT AND DEVICES SHALL BE METALICALLY JOINED TOGETHER TO PROVIDE EFFECTIVE ELECTRICAL CONTINUITY.
- FEEDERS AND BRANCH CIRCUIT WIRING INSTALLED IN A NONMETALLIC CONDUIT SHALL INCLUDE A CODE SIZED GROUNDING CONDUCTOR HAVING GREEN INSULATION. THE GROUND CONDUCTOR SHALL BE PROPERLY CONNECTED AT BOTH ENDS TO MAINTAIN ELECTRICAL CONTINUITY.
- REFER TO GROUND BUS DETAILS. PROVIDE NEW GROUND SYSTEM COMPLETE WITH CONDUCTORS, GROUND ROD AND DESCRIBED TERMINATIONS.
- ALL GROUNDING CONDUCTORS SHALL BE SOLID TINNED COPPER AND ANNEALED #2 UNLESS NOTED OTHERWISE.
- ALL NON-DIRECT BURIED TELEPHONE EQUIPMENT GROUND CONDUCTORS SHALL BE #2 STRANDED THHN (GREEN) INSULATION.
- ALL GROUND CONNECTIONS SHALL BE MADE WITH "HYGROUND" COMPRESSION SYSTEM BURNDY CONNECTORS EXCEPT WHERE NOTED OTHERWISE.
- PAINT AT ALL GROUND CONNECTIONS SHALL BE REMOVED.
- GROUNDING SYSTEM RESISTANCE SHALL NOT EXCEED 5 OHMS. IF THE RESISTANCE VALUE IS EXCEEDED, NOTIFY THE OWNER FOR FUTURE INSTRUCTION ON METHODS FOR REDUCING THE RESISTANCE VALUE. SUBMIT TEST REPORTS AND FURNISH TO SMART SMR ONE COMPLETE SET OF PRINTS SHOWING "INSTALLED WORK".

**UTILITY SERVICE:**

- TELEPHONE AND ELECTRICAL METERING FACILITIES SHALL CONFORM TO THE REQUIREMENTS OF THE SERVING UTILITY COMPANIES. CONTRACTOR SHALL VERIFY SERVICE LOCATIONS AND REQUIREMENTS. SERVICE INFORMATION WILL BE FURNISHED BY THE SERVING UTILITIES.
- CONFORM TO ALL REQUIREMENTS OF THE SERVING UTILITY COMPANIES.

**PRODUCTS:**

- ALL MATERIALS SHALL BE NEW, CONFORMING WITH NEC, ANSI, NEMA, AND THEY SHALL BE U.L. LISTED AND LABELED.
- CONDUIT:
  - RIGID CONDUIT SHALL BE U.L. LABEL GALVANIZED ZINC COATED WITH ZINC INTERIOR AND SHALL BE USED WHEN INSTALLED IN OR UNDER CONCRETE SLABS, IN CONTACT WITH THE EARTH, UNDER PUBLIC ROADWAYS, IN MASONRY WALLS OR EXPOSED ON BUILDING EXTERIOR. RIGID CONDUIT IN CONTACT WITH EARTH SHALL BE 1/2 LAPPED WRAPPED WITH HUNTS WRAP PROCESS NO. 3.
  - ELECTRICAL METALLIC TUBING SHALL U.L. LABEL. FITTINGS SHALL BE COMPRESSION TYPE. EMT SHALL BE USED ONLY FOR INTERIOR RUNS.
  - FLEXIBLE METALLIC CONDUIT SHALL HAVE U.L. LISTED LABEL AND MAY BE USED WHERE PERMITTED BY CODE. FITTINGS SHALL BE "JAKE" OR "SQUEEZE" TYPE. SEAL TIGHT FLEXIBLE CONDUIT. ALL CONDUIT EXCESS OF SIX FEET IN LENGTH SHALL HAVE FULL SIZE GROUND WIRE.
  - CONDUIT RUNS MAY BE SURFACE MOUNTED IN CEILING OR WALLS UNLESS INDICATED OTHERWISE. CONDUIT INDICATED SHALL RUN PARALLEL OR AT RIGHT ANGLES TO CEILING, FLOOR OR BEAMS. VERIFY EXACT ROUTING OF ALL EXPOSED CONDUIT WITH ARCHITECT PRIOR TO INSTALLING.
  - ALL UNDERGROUND CONDUITS SHALL BE PVC SCHEDULE 40 (UNLESS NOTED OTHERWISE) AT A MINIMUM DEPTH OF 24" BELOW GRADE
  - ALL CONDUIT ONLY (C.O.) SHALL HAVE PULL ROPE.
  - CONDUITS RUN ON ROOFS SHALL BE INSTALLED ON 4x4 REDWOOD SLEEPERS, 6'-0" ON CENTER, SET IN NON-HARDENING MASTIC.
- ALL WIRE AND CABLE SHALL BE COPPER, 600 VOLT, #12 AWG MINIMUM UNLESS SPECIFICALLY NOTED OTHERWISE ON THE DRAWINGS. CONDUCTORS #10 AWG AND SMALLER SHALL BE SOLID. CONDUCTORS #8 AWG AND LARGER SHALL BE STRANDED. TYPE THHN INSULATION USED UNLESS CONDUCTORS INSTALLED IN CONDUIT EXPOSED TO WEATHER, IN WHICH CASE TYPE THWN INSULATION SHALL BE USED.
- PROVIDE GALVANIZED COATED STEEL BOXES AND ACCESSORIES SIZED PER CODE TO ACCOMMODATE ALL DEVICES AND WIRING.
- DUPLEX RECEPTACLES SHALL BE SPECIFICATION GRADE WITH WHITE FINISH (UNLESS NOTED BY ENGINEER), 20 AMP, 125 VOLT, THREE WIRE GROUNDING TYPE, NEMA 5-20R. MOUNT RECEPTACLE AT +12" ABOVE FINISHED FLOOR UNLESS OTHERWISE INDICATED ON DRAWINGS OR IN DETAILS. WEATHERPROOF RECEPTACLES SHALL BE GROUND FAULT INTERRUPTER TYPE WITH SIERRA #WPD-8 LIFT COVERPLATES.
- TOGGLE SWITCHES SHALL BE 20 AMP, 120 VOLT AC, SPECIFICATION GRADE WHITE (UNLESS NOTED OTHERWISE) FINISH. MOUNT SWITCHES AT +48" ABOVE FINISHED FLOOR.
- PANELBOARDS SHALL BE DEAD FRONT SAFETY TYPE WITH ANTI-BURN SOLDERLESS COMPRESSION APPROVED FOR COPPER CONDUCTORS, COPPER BUS BARS, FULL SIZED NEUTRAL BUS, GROUND BUS AND EQUIPPED WITH QUICK-MAKE QUICK-BREAK BOLT-IN TYPE THERMAL MAGNETIC CIRCUIT BREAKERS. MOUNT TOP OF THE PANELBOARDS AT 6'-3" ABOVE FINISHED FLOOR. PROVIDE TYPE WRITTEN CIRCUIT DIRECTORY.
- ALL CIRCUIT BREAKERS, MAGNETIC STARTERS AND OTHER ELECTRICAL EQUIPMENT SHALL HAVE AN INTERRUPTING RATING NOT LESS THAN MAXIMUM SHORT CIRCUIT CURRENT TO WHICH THEY MAY BE SUBJECTED.
- GROUND RODS SHALL BE COPPER CLAD STEEL, 5/8" ROUND AND 10' LONG. COPPERWELD OR APPROVED EQUAL.

**INSTALLATION:**

- PROVIDE SUPPORTING DEVICES FOR ALL ELECTRICAL EQUIPMENT, FIXTURES, BOXES, PANEL, ETC., SUPPORT LUMINARIES FROM UNDERSIDE OF STRUCTURAL CEILING. EQUIPMENT SHALL BE BRACED TO WITHSTAND HORIZONTAL FORCES IN ACCORDANCE WITH STATE AND LOCAL CODE REQUIREMENTS. PROVIDE PRIOR ALIGNMENT AND LEVELING OF ALL DEVICES AND FIXTURES.
- CUTTING, PATCHING, CHASES, OPENINGS: PROVIDE LAYOUT IN ADVANCE TO ELIMINATE UNNECESSARY CUTTING OR DRILLING OF WALLS, FLOORS CEILINGS, AND ROOFS. ANY DAMAGE TO BUILDING STRUCTURE OR EQUIPMENT SHALL BE REPAIRED BY THE CONTRACTOR. OBTAIN PERMISSION FROM THE ENGINEER BEFORE CORING.
- IN DRILLING HOLES INTO CONCRETE WHETHER FOR FASTENING OR ANCHORING PURPOSES, OR PENETRATIONS THROUGH THE FLOOR FOR CONDUIT RUNS, PIPE RUNS, ETC., IT MUST BE CLEARLY UNDERSTOOD THAT TENDONS AND/OR REINFORCING STEEL WILL NOT BE DRILLED INTO, CUT OR DAMAGED UNDER THE CIRCUMSTANCES.
- LOCATION OF TENDONS AND/OR REINFORCING STEEL ARE NOT DEFINITELY KNOWN AND THEREFORE, MUST BE SEARCHED FOR BY APPROPRIATE METHODS AND EQUIPMENT VIA X-RAY OR OTHER DEVICES THAT CAN ACCURATELY LOCATE THE REINFORCING AND/OR STEEL TENDONS.
- PENETRATIONS IN FIRE RATED WALLS SHALL BE FIRE STOPPED IN ACCORDANCE WITH THE REQUIREMENTS OF THE C.B.C.

**PROJECT CLOSEOUT:**

- UPON COMPLETION OF WORK, CONDUCT CONTINUITY, SHORT CIRCUIT, AND FALL POTENTIAL GROUNDING TESTS FOR APPROVAL. SUBMIT TEST REPORTS TO PROJECT MANAGER. CLEAN PREMISES OF ALL DEBRIS RESULTING FROM WORK AND LEAVE WORK IN A COMPLETE AND UNMAYED CONDITION.
- PROVIDE PROJECT MANAGER WITH ONE SET OF COMPLETE ELECTRICAL "AS INSTALLED" DRAWINGS AT THE COMPLETION OF THE JOB, SHOWING ACTUAL DIMENSIONS, ROUTINGS AND CIRCUITS.
- ALL BROCHURES, OPERATING MANUALS, CATALOG, SHOP DRAWINGS, ETC., SHALL BE TURNED OVER TO OWNER AT JOB COMPLETION.

**GROUNDING NOTES:**

- ALL DETAILS ARE SHOWN IN GENERAL TERMS. ACTUAL GROUNDING INSTALLATION REQUIREMENTS AND CONSTRUCTION ACCORDING TO SITE CONDITIONS.
- ALL GROUNDING CONDUCTORS: #2 AWG SOLID BARE TINNED COPPER WIRE UNLESS OTHERWISE NOTED.
- GROUND BAR LOCATED IN BASE OF EQUIPMENT WILL BE PROVIDED, FURNISHED AND INSTALLED BY THE VENDOR.
- ALL BELOW GRADE CONNECTIONS: EXOTHERMIC WELD TYPE, ABOVE GRADE CONNECTIONS: EXOTHERMIC WELD TYPE.
- GROUND RING SHALL BE LOCATED A MINIMUM OF 24" BELOW GRADE OR 6" MINIMUM BELOW THE FROST LINE.
- INSTALL GROUND CONDUCTORS AND GROUND ROD MINIMUM OF 1'-0" FROM EQUIPMENT CONCRETE SLAB, SPREAD FOOTING, OR FENCE.
- EXOTHERMIC WELD GROUND CONNECTION TO FENCE POST: TREAT WITH A COLD GALVANIZED SPRAY.
- GROUND BARS:
  - EQUIPMENT GROUND BUS BAR (EGB) LOCATED AT THE BOTTOM OF ANTENNA POLE/MAST FOR MAKING GROUNDING JUMPER CONNECTIONS TO COAX FEEDER CABLES SHALL BE FURNISHED AND INSTALLED BY ELECTRICAL CONTRACTOR. JUMPERS (FURNISHED BY OWNERS) SHALL BE INSTALLED AND CONNECTED BY ELECTRICAL CONTRACTOR.
- ALL GROUNDING INSTALLATIONS AND CONNECTIONS SHALL BE MADE BY ELECTRICAL CONTRACTOR.
- OBSERVE N.E.C. AND LOCAL UTILITY REQUIREMENTS FOR ELECTRICAL SERVICE GROUNDING.
- GROUNDING ATTACHMENT TO TOWER SHALL BE AS PER MANUFACTURER'S RECOMMENDATIONS OR AT GROUNDING POINTS PROVIDED (2 MINIMUM).
- IF EQUIPMENT IS IN A C.L. FENCE ENCLOSURE, GROUND ONLY CORNER POSTS AND SUPPORT POSTS OF GATE. IF CHAIN LINK LID IS USED, THEN GROUND LID ALSO.
- GROUNDING AT PPC CABINET SHALL BE VERTICALLY INSTALLED.
- ALL GROUNDING FOR ANTENNAS SHALL BE CONNECTED SO THAT IT WILL BY-PASS MAIN BUSS BAR.
- ALL EMT RUNS SHALL BE GROUNDED AND HAVE A BUSHING, NO PVC ABOVE GROUND.
- USE SEPARATE HOLES FOR GROUNDING AT BUSS BAR. NO "DOUBLE-UP" OF IUGS.
- POWER AND TELCO CABINETS SHALL BE GROUNDED (BONDED) TOGETHER.
- NO LBS ALLOWED ON GROUNDING.
- PROVIDE STAINLESS STEEL CLAMP AND BRASS TAGS ON COAX AT ANTENNAS AND DOGHOUSE.

NOTE:  
NEW VINYL SIGN TO BE PROVIDED BY VERICON WIRELESS AND BE LOCATED ON THE SIDE OF THE METER BOX. SIGN TO BE YELLOW.

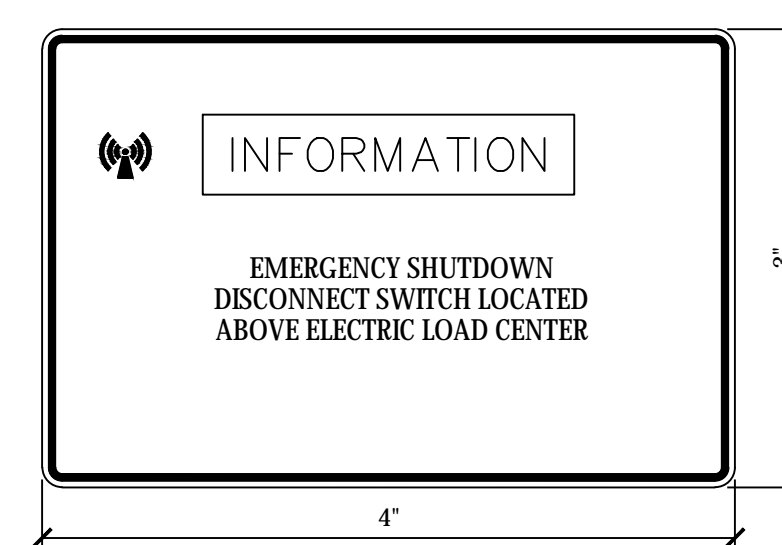

**4 SHUTDOWN DISCONNECT SIGNAGE**  
NOT TO SCALE

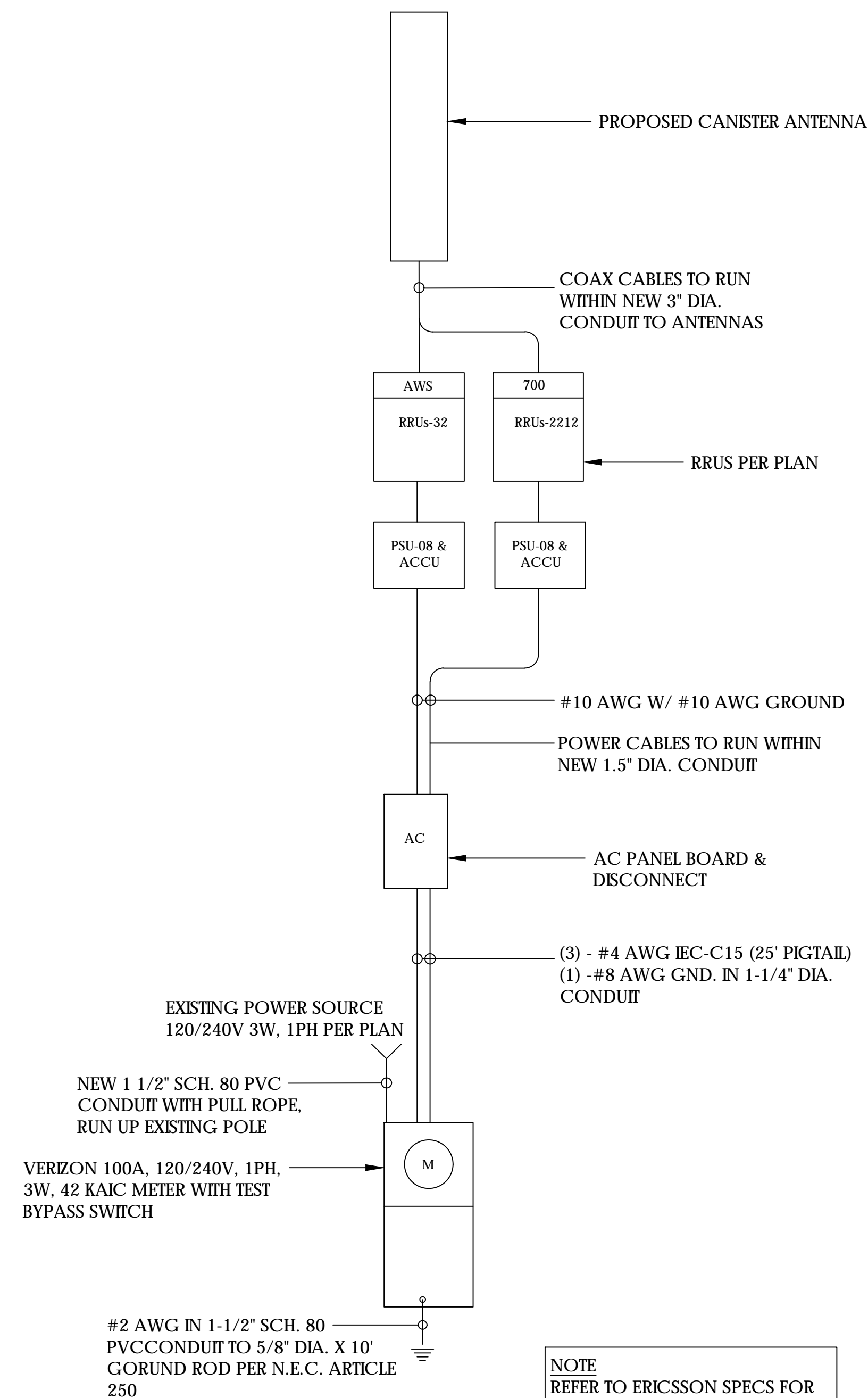

NOTE:  
REFER TO ERICSSON SPECS FOR ADDITIONAL INFORMATION INCLUDING WIRING INSTRUCTIONS & GROUNDING REQUIREMENTS

**5 ELECTRICAL NOTES**  
N.I.S.



2785 MITCHELL DRIVE, SUITE 9  
WALNUT CREEK, CA 94598



modus-corp.com

240 STOCKTON STREET, 3RD FLOOR  
SAN FRANCISCO, CA 94108



borgesarch.com

1478 STONE POINT DRIVE, SUITE 350  
ROSEVILLE CA 95661  
916 782 7200 TEL  
916 773 3037 FAX

REV	DATE	DESCRIPTION
1	02/21/18	90% CD SUBMITTAL
0	10/24/17	90% CD SUBMITTAL

**SITE NUMBER:**

**BUR\_018**

**SITE ADDRESS:**  
138 VALDEFLORES DR  
BURLINGAME, CA 94010

STAMP



DRAWN BY: D.A.G. PROJECT NO.: T-16519-48

CHECK BY: B.K.W.

**SHEET TITLE**  
**SINGLE LINE**  
**DIAGRAM & PANEL**  
**SCHEDULE**

SHEET NO.



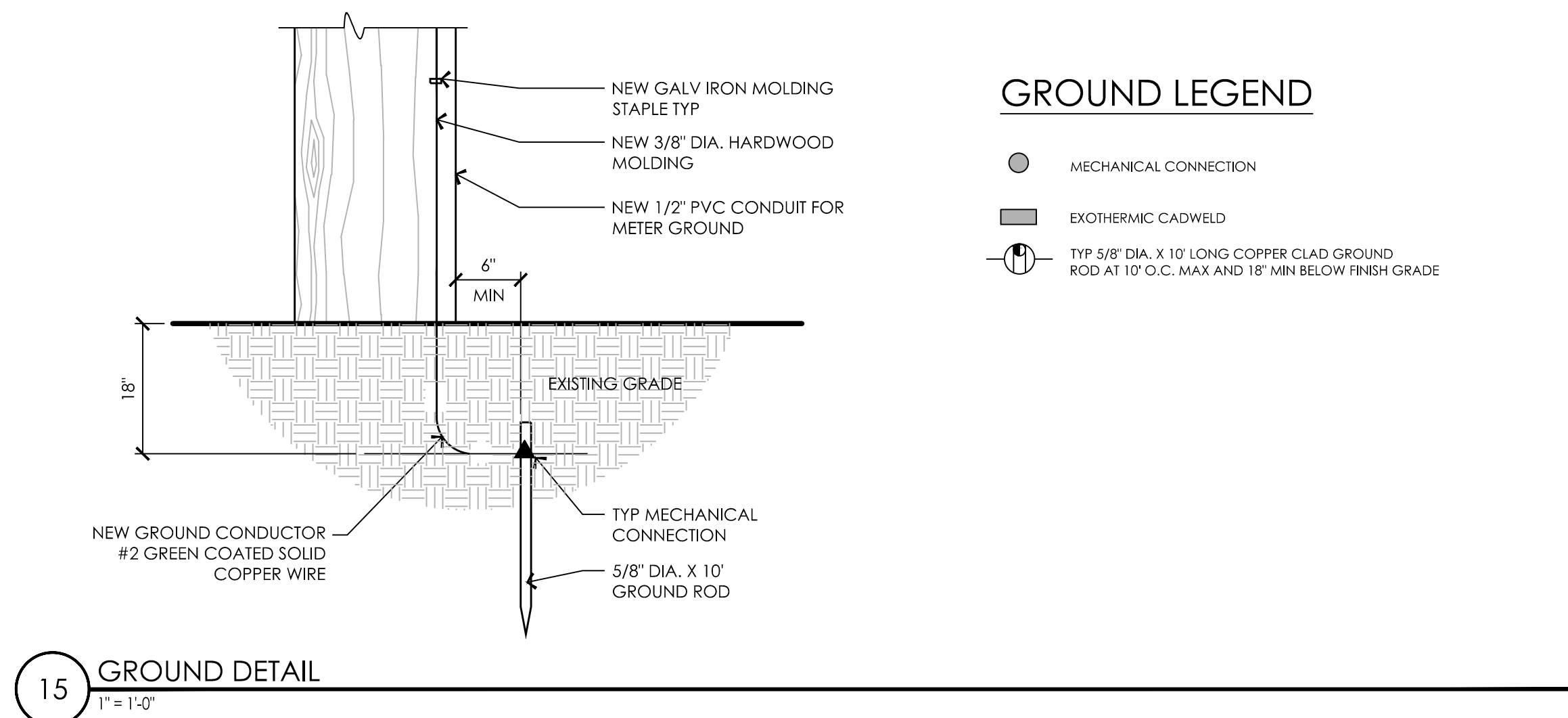

**5** GROUNDING PLAN  
1/2" = 1'-0"

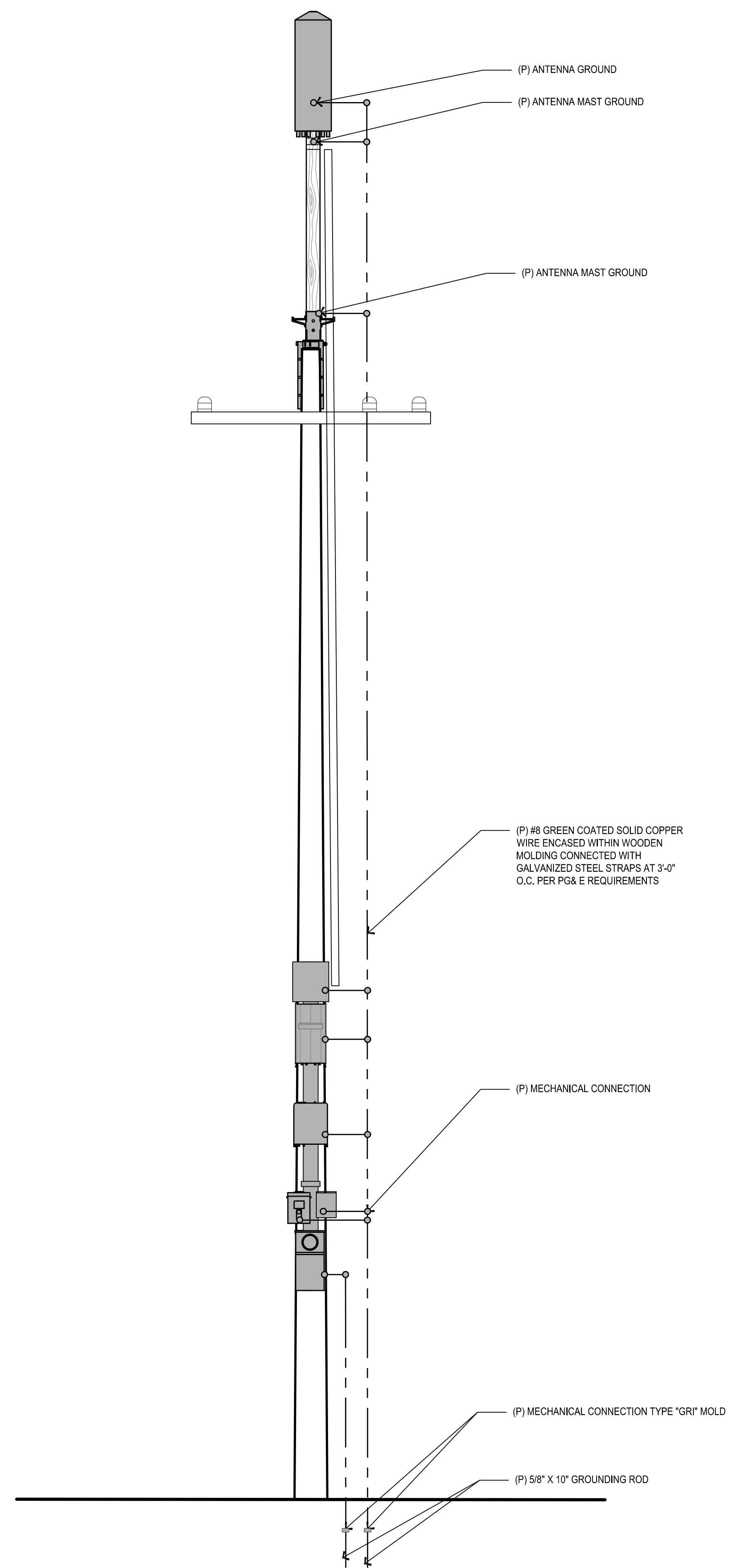

REV	DATE	DESCRIPTION
1	02/21/18	90% CD SUBMITTAL
0	10/24/17	90% CD SUBMITTAL

**SITE NUMBER:**

**BUR\_018**

**SITE ADDRESS:**  
138 VALDEFLORES DR  
BURLINGAME, CA 94010

STAMP

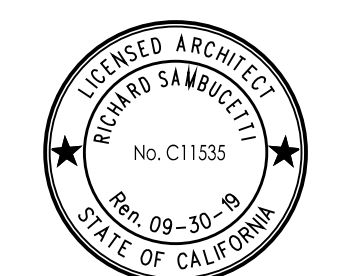

DRAWN BY: D.A.G. PROJECT NO.: T-16519-48  
CHECK BY: B.K.W.

**SHEET TITLE**  
POLE GROUND &  
RISER DIAGRAM &  
DETAILS

SHEET NO.





**County of San Mateo - Planning and Building Department**

# **ATTACHMENT C-2**

view from Valdeflores Drive looking west at site



SF Burlingame 018  
138 Valdeflores Drive, Burlingame, CA  
Photosims Produced on 2-23-2018

Existing

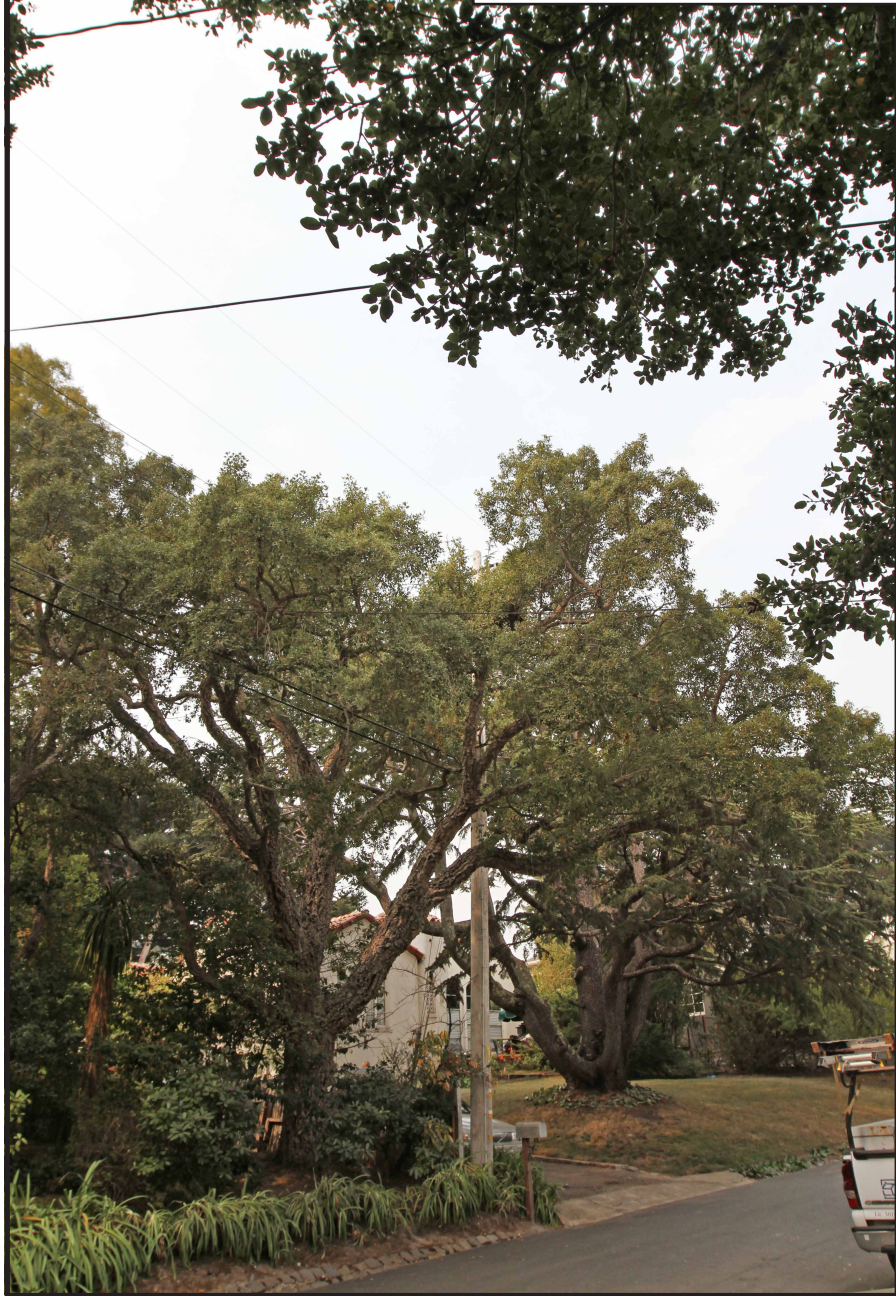

Proposed

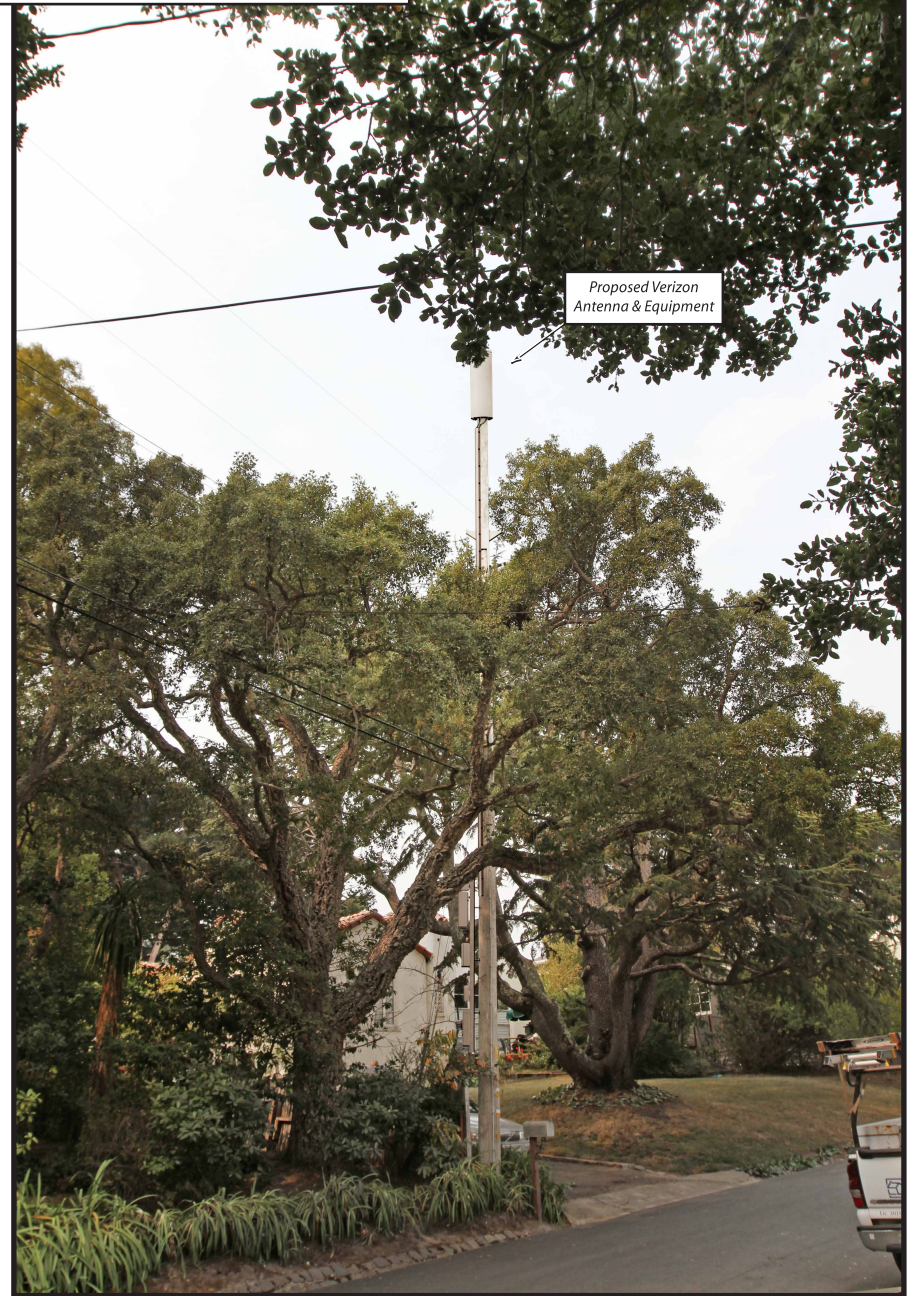

*Existing*



*Proposed*



Proposed Verizon Antenna & Equipment

*view from Valdeflores Drive looking northwest at site*  
SF Burlingame 018  
138 Valdeflores Drive, Burlingame, CA  
Photosims Produced on 2-23-2018



**County of San Mateo - Planning and Building Department**

# **ATTACHMENT C-3**



PG&E Wood Utility Pole:  
pole is located between two  
driveways and is thus  
unviable according to PG&E  
safety guidelines

PG&E Wood Utility Pole:  
pole is located between two  
driveways and is thus  
unviable according to PG&E  
safety guidelines

 Site Selected

PG&E Wood Utility Pole: too  
busy, pole has limited space  
due to risers and transformer  
and would require tree  
abatement



**County of San Mateo - Planning and Building Department**

# **ATTACHMENT C-4**

# Radio Frequency - Electromagnetic Energy (RF-EME) Jurisdictional Report

Site No. BUR\_018  
SF Burlingame 018  
138 Valdeflores Dr.  
Burlingame, California 94010  
San Mateo County  
37° 34' 29.76" N, -122° 23' 27.79" W NAD83

EBI Project No. 6218000838  
March 13, 2018



Prepared for:  
Verizon Wireless  
c/o Modus  
240 Stockton Street, 3rd Floor  
San Francisco, CA 94108

Prepared by:  
 **EBI Consulting**  
environmental | engineering | due diligence

## TABLE OF CONTENTS

<b>EXECUTIVE SUMMARY</b> .....	<b>1</b>
<b>1.0 INTRODUCTION</b> .....	<b>2</b>
<b>2.0 SITE DESCRIPTION</b> .....	<b>2</b>
<b>3.0 FEDERAL COMMUNICATIONS COMMISSION (FCC) REQUIREMENTS</b> .....	<b>3</b>
<b>4.0 WORST-CASE PREDICTIVE MODELING</b> .....	<b>5</b>
<b>5.0 MITIGATION/SITE CONTROL OPTIONS</b> .....	<b>6</b>
<b>6.0 SUMMARY AND CONCLUSIONS</b> .....	<b>6</b>
<b>7.0 LIMITATIONS</b> .....	<b>6</b>

## APPENDICES

- APPENDIX A CERTIFICATIONS**
- APPENDIX B RADIO FREQUENCY ELECTROMAGNETIC ENERGY SAFETY / SIGNAGE PLANS**
- APPENDIX C ROOFVIEW® EXPORT FILES**



## EXECUTIVE SUMMARY

### Purpose of Report

EnviroBusiness Inc. (dba EBI Consulting) has been contracted by Verizon Wireless to conduct radio frequency electromagnetic (RF-EME) modeling for Verizon Site BUR\_018 located at 138 Valdeflores Dr. in Burlingame, California to determine RF-EME exposure levels from proposed Verizon wireless communications equipment at this site. As described in greater detail in Section 2.0 of this report, the Federal Communications Commission (FCC) has developed Maximum Permissible Exposure (MPE) Limits for general public exposures and occupational exposures. This report summarizes the results of RF-EME modeling in relation to relevant FCC RF-EME compliance standards for limiting human exposure to RF-EME fields.

### Statement of Compliance

A site is considered out of compliance with FCC regulations if there are areas that exceed the FCC exposure limits and there are no RF hazard mitigation measures in place. Any carrier which has an installation that contributes more than 5% of the applicable MPE must participate in mitigating these RF hazards.

As presented in the sections below, based on worst-case predictive modeling, there are no modeled areas on any accessible ground-level walking/working surface related to the proposed antennas that exceed the FCC's occupational or general public exposure limits at this site. Additionally, there are areas where workers who may be elevated above the ground may be exposed to power densities greater than the occupational limits. Therefore, workers should be informed about the presence and locations of antennas and their associated fields.

At the nearest walking/working surfaces to the Verizon antennas, the maximum power density generated by the Verizon antennas is approximately **10.20** percent of the FCC's general public limit (**2.04** percent of the FCC's occupational limit).

Recommended control measures are outlined in Section 5.0 and within a Site Safety Plan (attached); this plan includes instructions to shut down and lockout/tagout this wireless equipment in accordance with Verizon's standard operating protocol.

## 1.0 INTRODUCTION

Radio frequency waves are electromagnetic waves from the portion of the electromagnetic spectrum at frequencies lower than visible light and microwaves. The wavelengths of radio waves range from thousands of meters to around 30 centimeters. These wavelengths correspond to frequencies as low as 3 cycles per seconds (or hertz [Hz]) to as high as one gigahertz (one billion cycles per second).

Personal Communication (PCS) facilities used by Verizon in this area operate within a frequency range of 700-2100 MHz. Facilities typically consist of: 1) electronic transceivers (the radios or cabinets) connected to wired telephone lines; and 2) antennas that send the wireless signals created by the transceivers to be received by individual subscriber units (PCS telephones). Transceivers are typically connected to antennas by coaxial cables.

Because of the short wavelength of PCS services, the antennas require line-of-site paths for good propagation, and are typically installed a distance above ground level. Antennas are constructed to concentrate energy towards the horizon, with as little energy as possible scattered towards the ground or the sky. This design, combined with the low power of PCS facilities, generally results in no possibility for exposure to approach Maximum Permissible Exposure (MPE) levels, with the exception of in areas in the immediate vicinity of the antennas.

MPE limits do not represent levels where a health risk exists, since they are designed to provide a substantial margin of safety. These limits apply for continuous exposures and are intended to provide a prudent margin of safety for all persons, regardless of age, gender, size or health.

## 2.0 SITE DESCRIPTION

This project site includes one (1) wireless telecommunication antenna on a utility pole located at 138 Valdeflores Dr. in Burlingame, California.

Verizon Antenna Information (proposed Configuration)									
Antenna # and Model	Frequency (MHz)	# of Transmitters	Transmit Power (Watts)	Azimuth	Gain (dBd)	Feet above Ground (CL)	X	Y	Z (feet)
AI				35°					
Andrew DBXLH-6565A	700	2	60	155°	10.4	47.33	30	30	45.33
	2100	2	60	275°	14.05				

The FCC guidelines incorporate two separate tiers of exposure limits that are based upon occupational/controlled exposure limits (for workers) and general population/uncontrolled exposure limits for members of the general public that may be exposed to antenna fields. While access to this site is considered uncontrolled, the analysis has considered exposures with respect to both controlled and uncontrolled limits as an untrained worker may access adjacent rooftop locations. Additional information regarding controlled/uncontrolled exposure limits is provided in Section 3.0. Appendix B presents a site safety plan that provides a plan view of the utility pole with antenna locations.

### 3.0 FEDERAL COMMUNICATIONS COMMISSION (FCC) REQUIREMENTS

The FCC has established Maximum Permissible Exposure (MPE) limits for human exposure to Radiofrequency Electromagnetic (RF-EME) energy fields, based on exposure limits recommended by the National Council on Radiation Protection and Measurements (NCRP) and, over a wide range of frequencies, the exposure limits developed by the Institute of Electrical and Electronics Engineers, Inc. (IEEE) and adopted by the American National Standards Institute (ANSI) to replace the 1982 ANSI guidelines. Limits for localized absorption are based on recommendations of both ANSI/IEEE and NCRP.

The FCC guidelines incorporate two separate tiers of exposure limits that are based upon occupational/controlled exposure limits (for workers) and general public/uncontrolled exposure limits for members of the general public.

**Occupational/controlled exposure limits** apply to situations in which persons are exposed as a consequence of their employment and in which those persons who are exposed have been made fully aware of the potential for exposure and can exercise control over their exposure. Occupational/controlled exposure limits also apply where exposure is of a transient nature as a result of incidental passage through a location where exposure levels may be above general public/uncontrolled limits (see below), as long as the exposed person has been made fully aware of the potential for exposure and can exercise control over his or her exposure by leaving the area or by some other appropriate means.

**General public/uncontrolled exposure limits** apply to situations in which the general public may be exposed or in which persons who are exposed as a consequence of their employment may not be made fully aware of the potential for exposure or cannot exercise control over their exposure. Therefore, members of the general public would always be considered under this category when exposure is not employment-related, for example, in the case of a telecommunications tower that exposes persons in a nearby residential area.

Table I and Figure I (below), which are included within the FCC’s OET Bulletin 65, summarize the MPE limits for RF emissions. These limits are designed to provide a substantial margin of safety. They vary by frequency to take into account the different types of equipment that may be in operation at a particular facility and are “time-averaged” limits to reflect different durations resulting from controlled and uncontrolled exposures.

The FCC’s MPEs are measured in terms of power (mW) over a unit surface area (cm<sup>2</sup>). Known as the power density, the FCC has established an occupational MPE of 5 milliwatts per square centimeter (mW/cm<sup>2</sup>) and an uncontrolled MPE of 1 mW/cm<sup>2</sup> for equipment operating in the 1900 MHz frequency range. For the Verizon equipment operating at 700 MHz or 850 MHz, the FCC’s occupational MPE is 2.83 mW/cm<sup>2</sup> and an uncontrolled MPE of 0.57 mW/cm<sup>2</sup>. These limits are considered protective of these populations.

Table I: Limits for Maximum Permissible Exposure (MPE)				
(A) Limits for Occupational/Controlled Exposure				
Frequency Range (MHz)	Electric Field Strength (E) (V/m)	Magnetic Field Strength (H) (A/m)	Power Density (S) (mW/cm <sup>2</sup> )	Averaging Time [E] <sup>2</sup> , [H] <sup>2</sup> , or S (minutes)
0.3-3.0	614	1.63	(100)*	6
3.0-30	1842/f	4.89/f	(900/f <sup>2</sup> )*	6
30-300	61.4	0.163	1.0	6

Table 1: Limits for Maximum Permissible Exposure (MPE)				
(A) Limits for Occupational/Controlled Exposure				
Frequency Range (MHz)	Electric Field Strength (E) (V/m)	Magnetic Field Strength (H) (A/m)	Power Density (S) (mW/cm <sup>2</sup> )	Averaging Time [E] <sup>2</sup> , [H] <sup>2</sup> , or S (minutes)
300-1,500	--	--	f/300	6
1,500-100,000	--	--	5	6
(B) Limits for General Public/Uncontrolled Exposure				
Frequency Range (MHz)	Electric Field Strength (E) (V/m)	Magnetic Field Strength (H) (A/m)	Power Density (S) (mW/cm <sup>2</sup> )	Averaging Time [E] <sup>2</sup> , [H] <sup>2</sup> , or S (minutes)
0.3-1.34	614	1.63	(100)*	30
1.34-30	824/f	2.19/f	(180/f <sup>2</sup> )*	30
30-300	27.5	0.073	0.2	30
300-1,500	--	--	f/1,500	30
1,500-100,000	--	--	1.0	30

f = Frequency in (MHz)

\* Plane-wave equivalent power density

Figure 1. FCC Limits for Maximum Permissible Exposure (MPE)  
 Plane-wave Equivalent Power Density

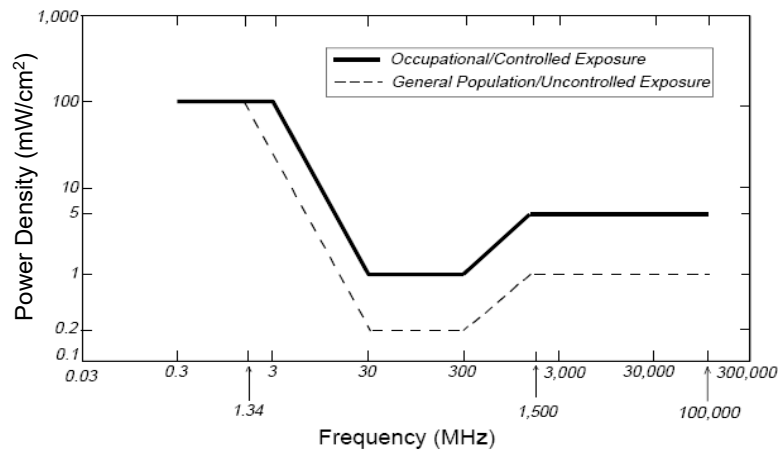

Based on the above, the most restrictive thresholds for exposures of unlimited duration to RF energy for several personal wireless services are summarized below:

Personal Wireless Service	Approximate Frequency	Occupational MPE	Public MPE
Personal Communication (PCS)	1,950 MHz	5.00 mW/cm <sup>2</sup>	1.00 mW/cm <sup>2</sup>
Cellular Telephone	870 MHz	2.90 mW/cm <sup>2</sup>	0.58 mW/cm <sup>2</sup>
Specialized Mobile Radio	855 MHz	2.85 mW/cm <sup>2</sup>	0.57 mW/cm <sup>2</sup>
Most Restrictive Freq, Range	30-300 MHz	1.00 mW/cm <sup>2</sup>	0.20 mW/cm <sup>2</sup>

MPE limits are designed to provide a substantial margin of safety. These limits apply for continuous exposures and are intended to provide a prudent margin of safety for all persons, regardless of age, gender, size, or health.

Personal Communication (PCS) facilities used by Verizon in this area operate within a frequency range of 700-2100 MHz. Facilities typically consist of: 1) electronic transceivers (the radios or cabinets) connected to wired telephone lines; and 2) antennas that send the wireless signals created by the transceivers to be received by individual subscriber units (PCS telephones). Transceivers are typically connected to antennas by coaxial cables.

Because of the short wavelength of PCS services, the antennas require line-of-sight paths for good propagation, and are typically installed above ground level. Antennas are constructed to concentrate energy towards the horizon, with as little energy as possible scattered towards the ground or the sky. This design, combined with the low power of PCS facilities, generally results in no possibility for exposure to approach Maximum Permissible Exposure (MPE) levels, with the exception of areas directly in front of the antennas.

#### **4.0 WORST-CASE PREDICTIVE MODELING**

EBI has performed theoretical modeling using RoofView® software to estimate the worst-case power density at the site ground-level resulting from operation of the antennas. RoofView® is a widely-used predictive modeling program that has been developed by Richard Tell Associates to predict both near field and far field RF power density values for roof-top and tower telecommunications sites produced by vertical collinear antennas that are typically used in the cellular, PCS, paging and other communications services. The models utilize several operational specifications for different types of antennas to produce a plot of spatially-averaged power densities that can be expressed as a percentage of the applicable exposure limit.

The modeling is based on worst-case assumptions for the number of antennas and transmitter power. The modeling assumes a maximum 4 radio configuration for the Tri-sector antenna, with a power level of 48 dbM (60 watts) per transmitter for 700 and 2100 frequencies, in order to provide a worst-case evaluation of predicted MPE levels. The assumptions used in the modeling are based upon information provided by Verizon, and information gathered from other sources. The parameters used for the modeling are summarized in the RoofView® export files presented in Appendix C.

There are no other wireless carriers with equipment installed at this site.

Based on worst-case predictive modeling, there are no modeled areas on any accessible ground-level walking/working surface related to the proposed Verizon antennas that exceed the FCC's occupational or general public exposure limits at this site. At the nearest walking/working surfaces to the Verizon antennas, the maximum power density generated by the Verizon antennas is approximately 10.20 percent of the FCC's general public limit (2.04 percent of the FCC's occupational limit).

The Site Safety Plan also presents areas where Verizon Wireless antennas contribute greater than 5% of the applicable MPE limit for a site. A site is considered out of compliance with FCC regulations if there are areas that exceed the FCC exposure limits and there are no RF hazard mitigation measures in place. Any carrier which has an installation that contributes more than 5% of the applicable MPE must participate in mitigating these RF hazards.

The inputs used in the modeling are summarized in the RoofView® export file presented in Appendix C. A graphical representation of the RoofView® modeling results is presented in Appendix B. It should be noted that RoofView is not suitable for modeling microwave dish antennas; however, these units are designed for point-to-point operations at the elevations of the installed equipment rather than ground level coverage.

## **5.0 MITIGATION/SITE CONTROL OPTIONS**

EBI's modeling indicates that there are no areas in front of the Verizon antennas that exceed the FCC standards for occupational or general public exposure. All exposures above the FCC's safe limits require that individuals be elevated above the ground. In order to alert people accessing the pole, a yellow CAUTION sign is recommended for installation approximately 10' below the antenna on the street side of pole.

These protocols and recommended control measures have been summarized and included with a graphic representation of the antennas and associated signage and control areas in a RF-EME Site Safety Plan, which is included as Appendix B. Individuals and workers accessing the pole should be provided with a copy of the attached Site Safety Plan, made aware of the posted signage, and signify their understanding of the Site Safety Plan.

Implementation of the signage recommended in the Site Safety Plan and in this report will bring this site into compliance with the FCC's rules and regulations.

## **6.0 SUMMARY AND CONCLUSIONS**

EBI has prepared a Radiofrequency – Electromagnetic Energy (RF-EME) Compliance Report for telecommunications equipment installed by Verizon Site Number BUR\_018 located at 138 Valdeflores Dr. in Burlingame, California to determine worst-case predicted RF-EME exposure levels from wireless communications equipment installed at this site. This report summarizes the results of RF-EME modeling in relation to relevant Federal Communications Commission (FCC) RF-EME compliance standards for limiting human exposure to RF-EME fields.

As presented in the sections above, based on the FCC criteria, there are no modeled areas on any accessible ground-level walking/working surface related to the proposed antennas that exceed the FCC's occupational or general public exposure limits at this site. The worst-case emitted power density may exceed the FCC's general public limit within approximately 10 feet of Verizon's proposed antenna at the antenna face level. Modeling also indicates that the worst-case emitted power density may exceed the FCC's occupational limit within approximately 4 feet of Verizon's proposed antenna at the antenna face level. Workers should be informed about the presence and locations of antennas and their associated fields. Recommended control measures are outlined in Section 5.0 and within a Site Safety Plan (attached); this plan includes procedures to shut down and lockout/tagout this wireless equipment in accordance with Verizon's standard operating protocol.

## **7.0 LIMITATIONS**

This report was prepared for the use of Verizon Wireless. It was performed in accordance with generally accepted practices of other consultants undertaking similar studies at the same time and in the same locale under like circumstances. The conclusions provided by EBI are based solely on the information provided by the client. The observations in this report are valid on the date of the investigation. Any additional information that becomes available concerning the site should be provided to EBI so that our conclusions may be revised and modified, if necessary. This report has been prepared in accordance with Standard Conditions for Engagement and authorized proposal, both of which are integral parts of this report. No other warranty, expressed or implied, is made.

# **Appendix A**

## **Certifications**

Reviewed and Approved by:



sealed 13mar2018

---

Michael McGuire  
Electrical Engineer

Note that EBI's scope of work is limited to an evaluation of the Radio Frequency – Electromagnetic Energy (RF-EME) field generated by the antennas and broadcast equipment noted in this report. The engineering and design of the structure, as well as the impact of the antennas and broadcast equipment on the structural integrity of the structure, are specifically excluded from EBI's scope of work.



## Preparer Certification

I, James Speed, state that:

- I am an employee of EnviroBusiness Inc. (d/b/a EBI Consulting), which provides RF-EME safety and compliance services to the wireless communications industry.
- I have successfully completed RF-EME safety training, and I am aware of the potential hazards from RF-EME and would be classified “occupational” under the FCC regulations.
- I am fully aware of and familiar with the Rules and Regulations of both the Federal Communications Commissions (FCC) and the Occupational Safety and Health Administration (OSHA) with regard to Human Exposure to Radio Frequency Radiation.
- I have reviewed the data provided by the client and incorporated it into this Site Compliance Report such that the information contained in this report is true and accurate to the best of my knowledge.

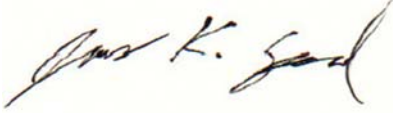
A rectangular box containing a handwritten signature in black ink. The signature appears to read "James K. Speed".

**Appendix B**  
**Radio Frequency Electromagnetic Energy**  
**Safety / Signage Plans**

**% FCC Public Exposure Limit**

	Exposure Level $\geq$ 5,000
	$500 <$ Exposure Level $\leq$ 5,000
	$100 <$ Exposure Level $\leq$ 500
	Exposure Level $\leq$ 100

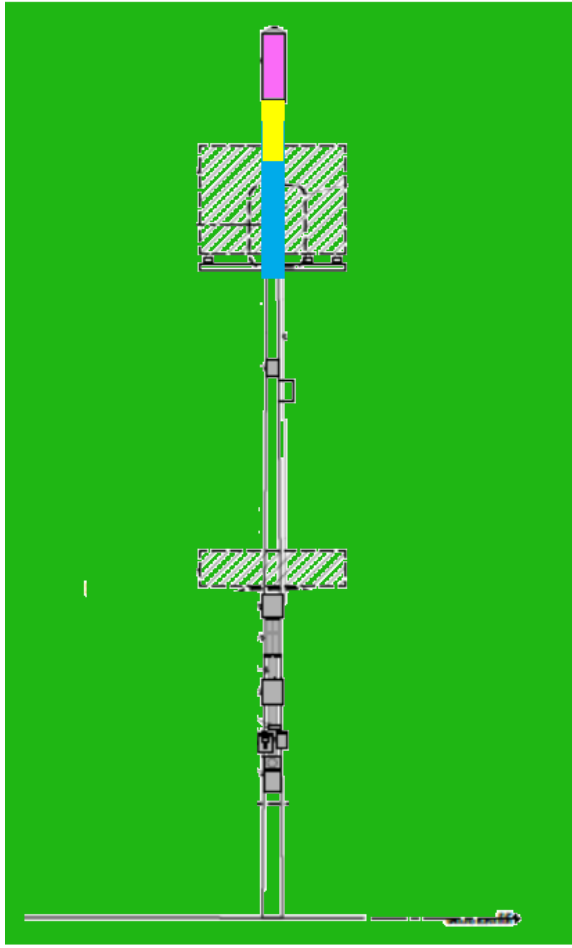
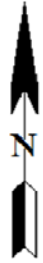

- Verizon Antennas
- Other Carrier Antennas

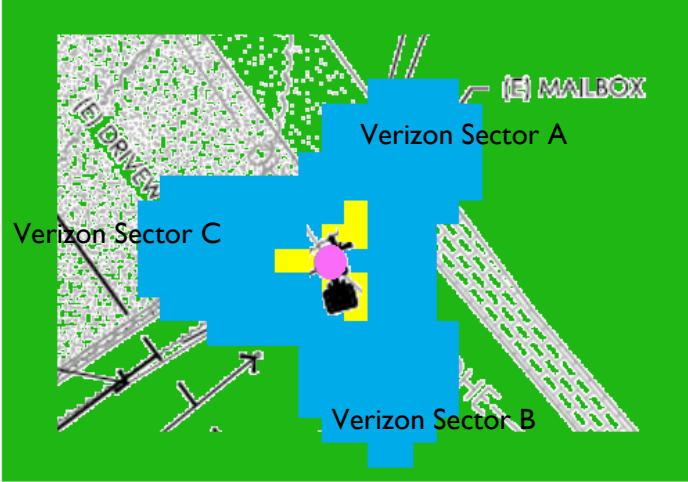

**Roofview: Composite Exposure Levels**

Facility Operator: Verizon Wireless  
 Site Name: SF Burlingame 018  
 Verizon Site Number: BUR\_018  
 Report Date: 03-13-18

**% FCC Public Exposure Limit**

-  Exposure Level > 5
-  Exposure Level ≤ 5

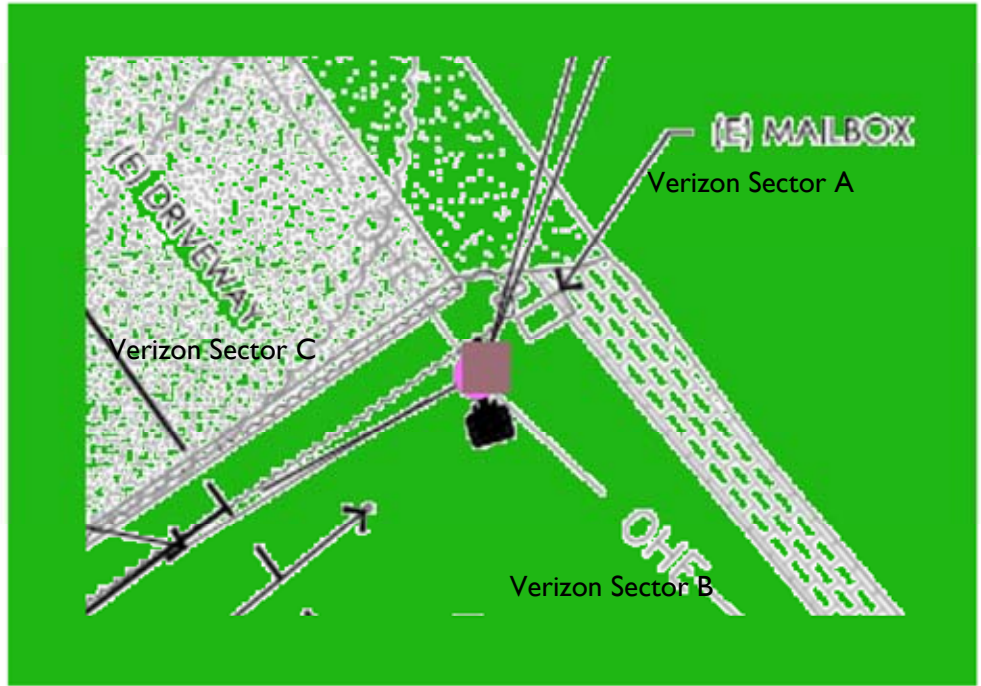
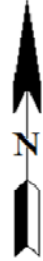

-  Verizon Antennas
-  Other Carrier Antennas

**Roofview: Verizon Exposure Levels**

Facility Operator: Verizon Wireless

Site Name: SF Burlingame 018

Verizon Site Number: BUR\_018

Report Date: 03-13-18

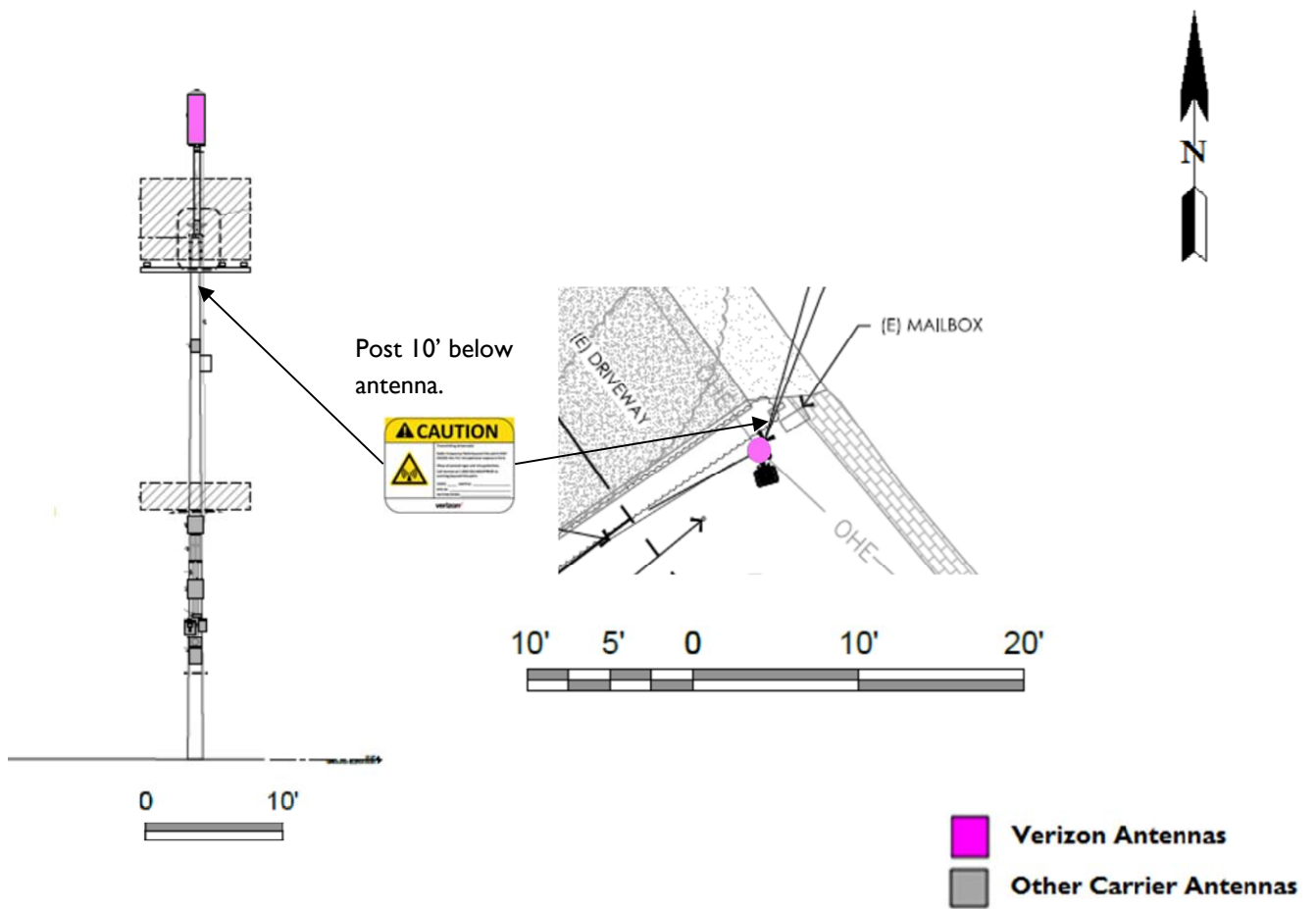

Sign Image	Description	Posting Instructions	Required Signage
	<p><b>Yellow Caution Sign</b></p> <p>Used to alert individuals that they are entering an area where the power density emitted from transmitting antennas may exceed the FCC's maximum permissible exposure limit for the general public and the occupational exposure limit.</p>	<p>Securely post in a manner conspicuous to all individuals entering thereon as indicated in the signage plan.</p>	<p>1 sign posted on street side of pole, 10' below bottom of antenna.</p>

## **Appendix C**

### **Roofview® Export File**

**StartMap** Definition

Roof Max X: 120 Roof Max Y: 120 Map Max X: 140 Map Max Y: 140 X Offset: 20 Y Offset: 20 Number of envelope: 1  
 \$AE\$81;\$SE\$AE\$81;\$ETS\$200

**StartSettings** Data

Standard Method Uptime Scale Factor Low Thr Low Color Mid Thr Mid Color Hi Thr Hi Color Over Color Ap Ht Mult Ap Ht Method  
 4 2 1 1 100 1 500 4 5000 2 3 1.5 1

**StartAntenna** Data

It is advisable to provide an ID (ant 1) for all antennas

ID	Name	Freq (MHz)	Power	Count	Len	Type	Loss	Input Power	Calc Power	Mfg	Model	X (ft)	Y (ft)	Z (ft)	Type	Aper (ft)	dBd Gain	BWdth Pt Dir	Uptime Profile	ON flag
VZW A1	LTE	700	40	1	0	0	1		31.77313	Amphenol	CUUT070X	30	30	45.33		4	10.35	82;35		ON•
VZW A1	LTE	2100	40	1	0	0	1		31.77313	Amphenol	CUUT070X	30	30	45.33		4	14.05	73.7;35		ON•
VZW A1	LTE	700	40	1	0	0	1		31.77313	Amphenol	CUUT070X	30	30	45.33		4	10.35	82;155		ON•
VZW A1	LTE	2100	40	1	0	0	1		31.77313	Amphenol	CUUT070X	30	30	45.33		4	14.05	73.7;155		ON•
VZW A1	LTE	700	40	1	0	0	1		31.77313	Amphenol	CUUT070X	30	30	45.33		4	10.35	82;275		ON•
VZW A1	LTE	2100	40	1	0	0	1		31.77313	Amphenol	CUUT070X	30	30	45.33		4	14.05	73.7;275		ON•

**StartSymbol** Data

Sym	Map Mark	Roof X	Roof Y	Map Label Description ( notes for this table only )
Sym		5	35	AC Unit Sample symbols
Sym		14	5	Roof Access
Sym		45	5	AC Unit
Sym		45	20	Ladder



**County of San Mateo - Planning and Building Department**

# **ATTACHMENT D-1**





**SITE NAME:** SF BURLINGAME 018  
**PROJECT ID#:** BUR\_018  
**LOCATION:** 438499  
**SITE ADDRESS:** 138 VALDEFLORES DR  
 BURLINGAME, CA 94010  
**COUNTY:** SAN MATEO  
**SITE TYPE:** PG&E POLE TOP



2785 MITCHELL DRIVE, SUITE 9  
 WALNUT CREEK, CA 94598



modus-corp.com

240 STOCKTON STREET, 3RD FLOOR  
 SAN FRANCISCO, CA 94108



borgesarch.com

1478 STONE POINT DRIVE, SUITE 350  
 ROSEVILLE CA 95661  
 916 782 7200 TEL  
 916 773 3037 FAX

**PROJECT DESCRIPTION**

THIS IS AN UNMANNED WIRELESS TELECOMMUNICATION FACILITY FOR VERIZON WIRELESS CONSISTING OF THE INSTALLATION AND OPERATION OF AN ANTENNA AND ASSOCIATED EQUIPMENT ON AN EXISTING UTILITY POLE IN THE PUBLIC RIGHT OF WAY.

**SCOPE OF WORK & SITE COMPLETION CHECKLIST**

- ANTENNA & ASSOCIATED EQUIPMENT BOXES - INSTALL A NEW TELECOMMUNICATION ANTENNA AND EQUIPMENT BOXES ON AN EXISTING WOOD UTILITY POLE ON G095 COMPLIANT STANDOFF BRACKET. INSTALLATION CONSISTS OF (1) CYLINDRICAL ANTENNA, (1) RRUS-32, (1) RRUS-2212 (1) ELECTRICAL METER, (1) LOAD CENTER & DISCONNECT SWITCH, (1) FIBER DEMARCATION BOX.
- CABLING - CABLING TO BE INSTALLED IN A TIDY MANNER WITHOUT EXCESS CABLE LOOPS
- SPACING OF SUPPORT ELEMENTS - SUPPORT EQUIPMENT (E.G. RRUS) TO BE CLUSTERED (VERTICALLY) AS CLOSE AS TECHNICALLY FEASIBLE ON POLE.
- LOGO REMOVAL - ALL EQUIPMENT LOGOS, OTHER THAN THOSE REQUIRED BY REGULATION (E.G. NODE IDENTIFICATION) SHALL BE PAINTED OVER OR REMOVED. RAISED OR DEPRESSED TEXT ON RRUS OR OTHER EQUIPMENT, IF PRESENT, SHALL BE SANDED OFF OR SIMILARLY REMOVED / FILLED.
- SIGNAGE - FCC MANDATED RF WARNING SIGNAGE SHALL FACE OUT TO STREET WHEN PLACED IN FRONT OF, OR NEAR A WINDOW. SIGNAGE SHALL FACE TOWARD A BUILDING IF THERE IS NO WINDOW.
- ALL CABLING, ANTENNAS, AND EQUIPMENT TO BE PAINTED TO MATCH POLE.

**CODE COMPLIANCE**

ALL WORK AND MATERIALS SHALL BE PERFORMED AND INSTALLED IN ACCORDANCE WITH THE CURRENT EDITIONS OF THE FOLLOWING CODES AS ADOPTED BY THE LOCAL GOVERNING AUTHORITIES. NOTHING IN THESE PLANS IS TO BE CONSTRUED TO PERMIT WORK NOT CONFORMING TO THESE CODES.

- 1) 2016 CALIFORNIA ADMINISTRATIVE CODE, CHAPTER 10, PART 1, TITLE 24 CODE OF REGULATIONS
- 2) 2016 CALIFORNIA BUILDING CODE (CBC) WITH CALIFORNIA AMENDMENTS, BASED ON THE 2015 IBC (PART 2, VOL 1-2)
- 3) 2016 CALIFORNIA RESIDENTIAL CODE (CRC) WITH APPENDIX H, PATIO COVERS, BASED ON THE 2015 IRC (PART 2.5)
- 4) 2016 CALIFORNIA GREEN BUILDINGS STANDARDS CODE (CALGREEN) (PART 11) (AFFECTED ENERGY PROVISIONS ONLY)
- 5) 2016 CALIFORNIA FIRE CODE (CFC), BASED ON THE 2015 IFC, WITH CALIFORNIA AMENDMENTS (PART 9)
- 6) 2016 CALIFORNIA MECHANICAL CODE (CMC), BASED ON THE 2015 UMC (PART 4)
- 7) 2016 CALIFORNIA PLUMBING CODE (CPC), BASED ON THE 2015 UPC (PART 5)
- 8) 2016 CALIFORNIA ELECTRICAL CODE (CEC) WITH CALIFORNIA AMENDMENTS, BASED ON THE 2015 NEC (PART 3)
- 9) 2016 CALIFORNIA ENERGY CODE (CEC)
- 10) ANSI / EIA-TIA-222-H
- 11) 2015 NFPA 101, LIFE SAFETY CODE
- 12) 2016 NFPA 72, NATIONAL FIRE ALARM CODE
- 13) 2016 NFPA 13, FIRE SPRINKLER CODE

**DISABLED ACCESS REQUIREMENTS**

FACILITY IS UNMANNED AND NOT FOR HUMAN HABITATION. ACCESSIBILITY REQUIREMENTS ARE NOT REQUIRED. IN ACCORDANCE WITH CALIFORNIA BUILDING CODE, CODE OF REGULATIONS, TITLE 24, PART 2, VOLUME 1, CHAPTER 11B, DIVISION 2, SECTION 11B-203.5

**VICINITY MAP**



**PROJECT INFORMATION**

**Property Information:**  
 Site Name: SF BURLINGAME 018  
 Site Number: BUR\_018  
 Site Address: 138 VALDEFLORES DR  
 BURLINGAME, CA 94010  
 A.P.N. Number: 027-063-270  
 Current Zoning: N/A - PUBLIC RIGHT OF WAY  
 Jurisdiction: CITY OF BURLINGAME  
 Latitude: N 37° 34' 29.76"  
 Longitude: W 122° 23' 27.79"  
 Elevation: +/-481.01' AMSL

**Power Agency:**  
 PG&E  
 1 MARKET STREET, SPEAR TOWER  
 SAN FRANCISCO, CA 94105-1126

**Telephone Agency:**  
 VERIZON WIRELESS  
 525 MARKET STREET  
 SAN FRANCISCO, CA 94105  
 ph: (415) 778-1231

**Property Owner:**  
 N/A - PUBLIC RIGHT OF WAY

**SHEET INDEX**

SHEET NO.	SHEET TITLE
T-1	TITLE SHEET
GN-1	GENERAL NOTES
C-1	SURVEY
A-1	SITE PLAN
A-2	ENLARGED SITE PLAN & ANTENNA PLAN
A-3.1	ELEVATIONS
A-3.2	ELEVATIONS
A-4.1	DETAILS
A-4.2	DETAILS
E-1	SINGLE LINE DIAGRAM & PANEL SCHEDULE
E-2	POLE GROUND & RISER DIAGRAM & DETAILS

**PROJECT TEAM**

**Agent:**  
 Scott Revard  
 Modus-Corporation, Inc.  
 240 Stockton Street, 3rd Floor  
 San Francisco, CA 94108  
 ph: (415) 595-0938  
 email: srevard@modus-corp.com

**Project Manager:**  
 Scott Revard  
 Modus-Corporation, Inc.  
 240 Stockton Street, 3rd Floor  
 San Francisco, CA 94108  
 ph: (415) 595-0938  
 email: srevard@modus-corp.com

**Construction Manager:**  
 Kresston Haynes  
 Modus-Corporation, Inc.  
 240 Stockton Street, 3rd Floor  
 San Francisco, CA 94108  
 ph: (209) 938-7251  
 email: khaynes@modus-corp.com

**Architect / Engineer of Record:**  
 Borges Architectural Group, Inc.  
 1478 Stone Point Drive, Suite 350  
 Roseville, CA 95661  
 contact: Brian K. Winslow  
 ph: (916) 782-7200  
 email: brian@borgesarch.com

**DIRECTIONS FROM VERIZON'S OFFICE**

DIRECTIONS FROM VERIZON WIRELESS'S OFFICE AT 2785 MITCHELL DRIVE, WALNUT CREEK, CA

1. DEPART MITCHELL DR TOWARD N WIGET LN
2. TURN LEFT ONTO N WIGET LN
3. TURN RIGHT ONTO YGNACIO VALLEY RD
4. ROAD NAME CHANGES TO HILLSIDE AVE
5. TAKE RAMP RIGHT FOR CA-24 WEST TOWARD OAKLAND
6. TAKE RAMP RIGHT FOR I-580 WEST TOWARD SACRAMENTO / SAN FRANCISCO
7. TAKE RAMP LEFT FOR I-80 WEST TOWARD SAN FRANCISCO
8. KEEP RIGHT ONTO I-80 W
9. KEEP STRAIGHT ONTO US-101 S
10. AT EXIT 423B, TAKE RAMP RIGHT FOR I-380 WEST TOWARD SAN BRUNO
11. AT EXIT 5B, TAKE RAMP LEFT FOR I-280 SOUTH TOWARD SAN JOSE
12. AT EXIT 39, TAKE RAMP RIGHT AND FOLLOW SIGNS FOR TROUSDALE DR
13. TURN LEFT ONTO TROUSDALE DR, AND THEN IMMEDIATELY TURN RIGHT ONTO SKYLINE BLVD
14. BEAR LEFT ONTO HILLSIDE DR
15. TURN RIGHT ONTO VALDEFLORES DR
16. ARRIVE AT VALDEFLORES DR

SIGNATURE BLOCK		
TITLE	SIGNATURE	DATE
VERIZON PM		
VERIZON CM		
VERIZON RF		
MODUS PM		
MODUS CM		
UTILITIES		
LANDLORD/ PROPERTY OWNER		

**OCCUPANCY AND CONSTRUCTION TYPE**

OCCUPANCY : N/A  
 CONSTRUCTION TYPE: G.O. 128 AND 2009 AASHTO 5TH EDITION STANDARD

**GENERAL CONTRACTOR NOTES**  
 DO NOT SCALE DRAWINGS

THESE DRAWINGS ARE FORMATTED TO BE FULL SIZE AT 36" x 24" (D1). CONTRACTOR SHALL VERIFY ALL PLANS AND EXISTING DIMENSIONS AND CONDITIONS ON THE JOBSITE AND SHALL IMMEDIATELY NOTIFY THE ARCHITECT/ENGINEER IN WRITING OF ANY DISCREPANCIES BEFORE PROCEEDING WITH THE WORK OR MATERIAL ORDERS OR BE RESPONSIBLE FOR THE SAME.



STAMP



DRAWN BY: D.A.G. PROJECT NO.: T-16519-48

CHECK BY: B.K.W.

SHEET TITLE

TITLE SHEET

SHEET NO.

**T-1**

**ABBREVIATIONS:**

A.B.	ANCHOR BOLT	IN. (")	INCH(ES)
ABV.	ABOVE	INT.	INTERIOR
ACCA	ANTENNA CABLE COVER ASSEMBLY	LB.(#)	POUND(S)
ADDL	ADDITIONAL	L.B.	LAG BOLTS
A.F.F.	ABOVE FINISHED FLOOR	L.F.	LINEAR FEET (FOOT)
A.F.G.	ABOVE FINISHED GRADE	L.	LONG(TUDINAL)
ALUM.	ALUMINUM	MAS.	MASONRY
ALT.	ALTERNATE	MAX.	MAXIMUM
ANT.	ANTENNA	M.B.	MACHINE BOLT
APPRX.	APPROXIMATE(LY)	MECH.	MECHANICAL
ARCH.	ARCHITECT(URAL)	MFR.	MANUFACTURER
AWG.	AMERICAN WIRE GAUGE	MIN.	MINIMUM
BLDG.	BUILDING	MISC.	MISCELLANEOUS
BLK.	BLOCK	MTL.	METAL
BLKG.	BLOCKING	(N)	NEW
BM.	BEAM	NO.(#)	NUMBER
B.N.	BOUNDARY NAILING	N.T.S.	NOT TO SCALE
BTCW.	BARE TINNED COPPER WIRE	O.C.	ON CENTER
B.O.F.	BOTTOM OF FOOTING	OPNG.	OPENING
BU	BACK-UP CABINET	(P)	PROPOSED
CAB.	CABINET	P/C	PRECAST CONCRETE
CANT.	CANTILEVER(ED)	PCS	PERSONAL COMMUNICATION SERVICES
C.I.P.	CAST IN PLACE	PLY.	PLYWOOD
CLG.	CEILING	PPC	POWER PROTECTION CABINET
CLR.	CLEAR	PRC	PRIMARY RADIO CABINET
COL.	COLUMN	P.S.F.	POUNDS PER SQUARE FOOT
CONC.	CONCRETE	P.S.I	POUNDS PER SQUARE INCH
CONN.	CONNECTION(OR)	P.T.	PRESSURE TREATED
CONST.	CONSTRUCTION	PWR.	POWER (CABINET)
CONT.	CONTINUOUS	QTY.	QUANTITY
d	DIAMETER	RAD.(R)	RADIUS
DBL.	DOUBLE	REF.	REFERENCE
DEPT.	DEPARTMENT	REIN.	REINFORCEMENT(ING)
D.F.	DOUGLAS FIR	REQD/	REQUIRED
DIA.	DIAMETER	RGS.	RIGID GALVANIZED STEEL
DIAG.	DIAGONAL	SCH.	SCHEDULE
DIM.	DIMENSION	SHT.	SHEET
DWG.	DRAWING(S)	SIM.	SIMILAR
DWL.	DOWEL(S)	SPEC.	SPECIFICATIONS
EA.	EACH	SQ.	SQUARE
EL.	ELEVATION	S.S.	STAINLESS STEEL
ELEC.	ELECTRICAL	STD.	STANDARD
ELEV.	ELEVATOR	STL.	STEEL
EMT.	ELECTRICAL METALLIC TUBING	STRUC.	STRUCTURAL
E.N.	EDGE NAIL	TEMP.	TEMPORARY
ENG.	ENGINEER	THK.	THICK(NESS)
EQ.	EQUAL	T.N.	TOE NAIL
EXP.	EXPANSION	T.O.A.	TOP OF ANTENNA
EXST.(E)	EXISTING	T.O.C.	TOP OF CURB
EXT.	EXTERIOR	T.O.F.	TOP OF FOUNDATION
FAB.	FABRICATION(OR)	T.O.P.	TOP OF PLATE (PARAPET)
F.F.	FINISH FLOOR	T.O.S.	TOP OF STEEL
F.G.	FINISH GRADE	T.O.W.	TOP OF WALL
FIN.	FINISH(ED)	TYP.	TYPICAL
FLR.	FLOOR	U.G.	UNDER GROUND
FDN.	FOUNDATION	U.L.	UNDERWRITERS LABORATORY
F.O.C.	FACE OF CONCRETE	U.N.O.	UNLESS NOTED OTHERWISE
F.O.M.	FACE OF MASONRY	V.I.F.	VERIFY IN FIELD
F.O.S.	FACE OF STUD	W	WIDE (WIDTH)
F.O.W.	FACE OF WALL	w/	WITH
F.S.	FINISH SURFACE	WD.	WOOD
FT. (')	FOOT (FEET)	W.P.	WEATHERPROOF
FTG.	FOOTING	WT.	WEIGHT
G.	GROWTH (CABINET)	C	CENTERLINE
GA.	GAUGE	L	PLATE, PROPERTY LINE
GI.	GALVANIZE(D)		
G.F.I.	GROUND FAULT CIRCUIT INTERRUPTER		
GLB. (GLU-LAM)	GLUE LAMINATED BEAM		
GPS	GLOBAL POSITIONING SYSTEM		
GRND.	GROUND		
HDR.	HEADER		
HGR.	HANGER		
HT.	HEIGHT		
ICGB.	ISOLATED COPPER GROUND BUS		

**SYMBOL LEGEND:**

	BLDG. SECTION		GROUT OR PLASTER
	WALL SECTION		(E) BRICK
	DETAIL		(E) MASONRY
	ELEVATION		CONCRETE
	DOOR SYMBOL		EARTH
	WINDOW SYMBOL		GRAVEL
	TILT-UP PANEL MARK		PLYWOOD
	PROPERTY LINE		SAND
	CENTERLINE		PLYWOOD
	ELEVATION DATUM		SAND
	GRID/COLUMN LINE		PLYWOOD
	KEYNOTE, DIMENSION ITEM		MATCH LINE
	KEYNOTE, CONSTRUCTION ITEM		GROUND CONDUCTOR
	WALL TYPE MARK		OVERHEAD SERVICE CONDUCTORS
	ROOM NAME		TELEPHONE CONDUIT
	ROOM NUMBER		POWER CONDUIT
			COAXIAL CABLE
			CHAIN LINK FENCE
			WOOD FENCE

**GENERAL NOTES:**

- THESE NOTES SHALL BE CONSIDERED A PART OF THE WRITTEN SPECIFICATIONS, CONTRACT AND CONSTRUCTION DOCUMENTS.
- THE WORK SHALL INCLUDE FURNISHING MATERIALS, EQUIPMENT, APPURTENANCES, AND LABOR NECESSARY TO COMPLETE ALL INSTALLATIONS AS INDICATED ON THE PLANS AND IN THE CONTRACT DOCUMENTS.
- PRIOR TO THE SUBMISSION OF BIDS, THE CONTRACTOR(S) SHALL VISIT THE JOB SITE(S) AND BE RESPONSIBLE FOR ALL CONTRACT DOCUMENTS, FIELD CONDITIONS AND DIMENSIONS, AND CONFIRM THE WORK MAY BE ACCOMPLISHED PER THE CONTRACT DRAWINGS. ANY DISCREPANCIES ARE TO BE BROUGHT TO THE ATTENTION OF THE IMPLEMENTATION ENGINEER AND ARCHITECT / ENGINEER PRIOR TO BID SUBMITTAL.
- THE CONTRACTOR SHALL RECEIVE WRITTEN AUTHORIZATION TO PROCEED ON ANY WORK NOT CLEARLY DEFINED OR IDENTIFIED IN THE CONTRACT AND CONSTRUCTION DOCUMENTS BEFORE STARTING ANY WORK.
- ALL WORK PERFORMED AND MATERIALS INSTALLED SHALL BE IN STRICT ACCORDANCE WITH ALL APPLICABLE CODES, REGULATIONS, AND ORDINANCES, INCLUDING APPLICABLE MUNICIPAL AND UTILITY COMPANY SPECIFICATIONS.
- THE CONTRACTOR SHALL INSTALL ALL EQUIPMENT AND MATERIALS IN ACCORDANCE WITH MANUFACTURER RECOMMENDATIONS. IF THE RECOMMENDATIONS ARE IN CONFLICT WITH THE CONTRACT AND CONSTRUCTION DOCUMENTS AND/OR APPLICABLE CODES OR REGULATIONS, REVIEW AND RESOLVE THE CONFLICT WITH DIRECTION FROM THE IMPLEMENTATION ENGINEER AND ARCHITECT/ENGINEER OF RECORD PRIOR TO PROCEEDING.
- THE CONTRACTOR SHALL BE SOLELY RESPONSIBLE FOR ALL CONSTRUCTION MEANS, METHODS, TECHNIQUES, SEQUENCES, AND PROCEDURES AND FOR COORDINATION OF ALL PORTIONS OF THE WORK UNDER THE CONTRACT INCLUDING CONTACT AND COORDINATION WITH THE IMPLEMENTATION ENGINEER AND WITH THE AUTHORIZED REPRESENTATIVE OF ANY OUTSIDE POLE OR PROPERTY OWNER.
- THE CONTRACTOR SHALL MAKE NECESSARY PROVISIONS TO PROTECT EXISTING IMPROVEMENTS, INCLUDING BUT NOT LIMITED TO PAVING, CURBS, VEGETATION, GALVANIZED SURFACE OR OTHER EXISTING ELEMENTS AND UPON COMPLETION OF THE WORK, REPAIR AND DAMAGE THAT OCCURRED DURING CONSTRUCTION TO THE SATISFACTION OF THE Satisfaction.
- CONTRACTOR IS TO KEEP THE GENERAL AREA CLEAN, HAZARD FREE, AND DISPOSE OF ALL DIRT, DEBRIS, RUBBISH, AND REMOVE EQUIPMENT NOT SPECIFIED AS REMAINING ON THE PROPERTY. LEAVE PREMISES IN CLEAN CONDITION DAILY.
- PLANS ARE INTENDED TO BE DIAGRAMMATIC ONLY AND SHOULD NOT BE SCALED UNLESS OTHERWISE NOTED. RELY ONLY ON ANNOTATED DIMENSIONS AND REQUEST INFORMATION IF ADDITIONAL DIMENSIONS ARE REQUIRED.
- THE EXISTENCE AND LOCATION OF UTILITIES AND OTHER AGENCY'S FACILITIES WERE OBTAINED BY A SEARCH OF AVAILABLE RECORDS. OTHER FACILITIES MAY EXIST. CONTRACTOR SHALL VERIFY LOCATIONS PRIOR TO START OF CONSTRUCTION AND USE EXTREME CARE AND PROTECTIVE MEASURES TO PREVENT DAMAGE TO THE FACILITIES. CONTRACTOR IS RESPONSIBLE FOR THE PROTECTION OF UTILITIES OR OTHER AGENCY'S FACILITIES WITHIN THE LIMITS OF THE WORK, WHETHER THEY ARE IDENTIFIED IN THE CONTRACT DOCUMENTS OR NOT.
- THE CONTRACTOR SHALL NOTIFY UNDERGROUND SERVICE ALERT (800) 227-2600, AT LEAST TWO WORKING DAYS PRIOR TO START OF ANY EXCAVATION.

**DEFINITIONS:**

- "TYPICAL" OR "TYP" MEANS THAT THIS ITEM IS SUBSTANTIALLY THE SAME ACROSS SIMILAR CONDITIONS. "TYP" SHALL BE UNDERSTOOD TO MEAN "TYPICAL WHERE OCCURS" AND SHALL NOT BE CONSIDERED AS WITHOUT EXCEPTION OR CONSIDERATION OF SPECIFIC CONDITIONS.
- "SIMILAR" MEANS COMPARABLE TO CHARACTERISTICS FOR THE CONDITION NOTED. VERIFY DIMENSIONS AND ORIENTATION ON PLAN.
- "AS REQUIRED" MEANS AS REQUIRED BY REGULATORY REQUIREMENTS, BY REFERENCES STANDARDS, BY EXISTING CONDITIONS, BY GENERALLY ACCEPTED CONSTRUCTION PRACTICE, OR BY THE CONTRACT DOCUMENTS.
- "ALIGN" MEANS ACCURATELY LOCATE FINISH FACES OF MATERIALS IN THE SAME PLANE.
- THE TERM "VERIFY" OF "V.I.F." SHALL BE UNDERSTOOD TO MEAN "VERIFY IN FIELD WITH ENGINEER" AND REQUIRES THAT THE CONTRACTOR CONFIRM INTENTION REGARDING NOTED CONDITION AND PROCEED ONLY AFTER RECEIVING DIRECTION.
- WHERE THE WORDS "OR EQUAL" OR WORDS OF SIMILAR INTENT FOLLOW A MATERIAL SPECIFICATION, THEY SHALL BE UNDERSTOOD TO REQUIRE SIGNED APPROVAL OF ANY DEVIATION TO SAID SPECIFICATION PRIOR TO CONTRACTOR'S ORDERING OR INSTALLATION OF SUCH PROPOSED EQUAL PRODUCT.
- "FURNISH" MEANS SUPPLY ONLY, OTHERS TO INSTALL.
- "INSTALL" MEANS INSTALL ITEMS FURNISHED BY OTHERS.
- "PROVIDE" MEANS FURNISH AND INSTALL.



2785 MITCHELL DRIVE, SUITE 9  
WALNUT CREEK, CA 94598



modus-corp.com

240 STOCKTON STREET, 3RD FLOOR  
SAN FRANCISCO, CA 94108



borgesarch.com

1478 STONE POINT DRIVE, SUITE 350  
ROSEVILLE CA 95661

916 782 7200 TEL  
916 773 3037 FAX

1	02/21/18	90% CD SUBMITTAL
0	10/24/17	90% CD SUBMITTAL
REV	DATE	DESCRIPTION

**SITE NUMBER:**

**BUR\_018**

**SITE ADDRESS:**  
138 VALDEFLORES DR  
BURLINGAME, CA 94010

STAMP



DRAWN BY: D.A.G. PROJECT NO.: T-16519-48

CHECK BY: B.K.W.

SHEET TITLE

**GENERAL NOTES**

SHEET NO.

**GN-1**



2 SITE PLAN  
SCALE: 1"=5'

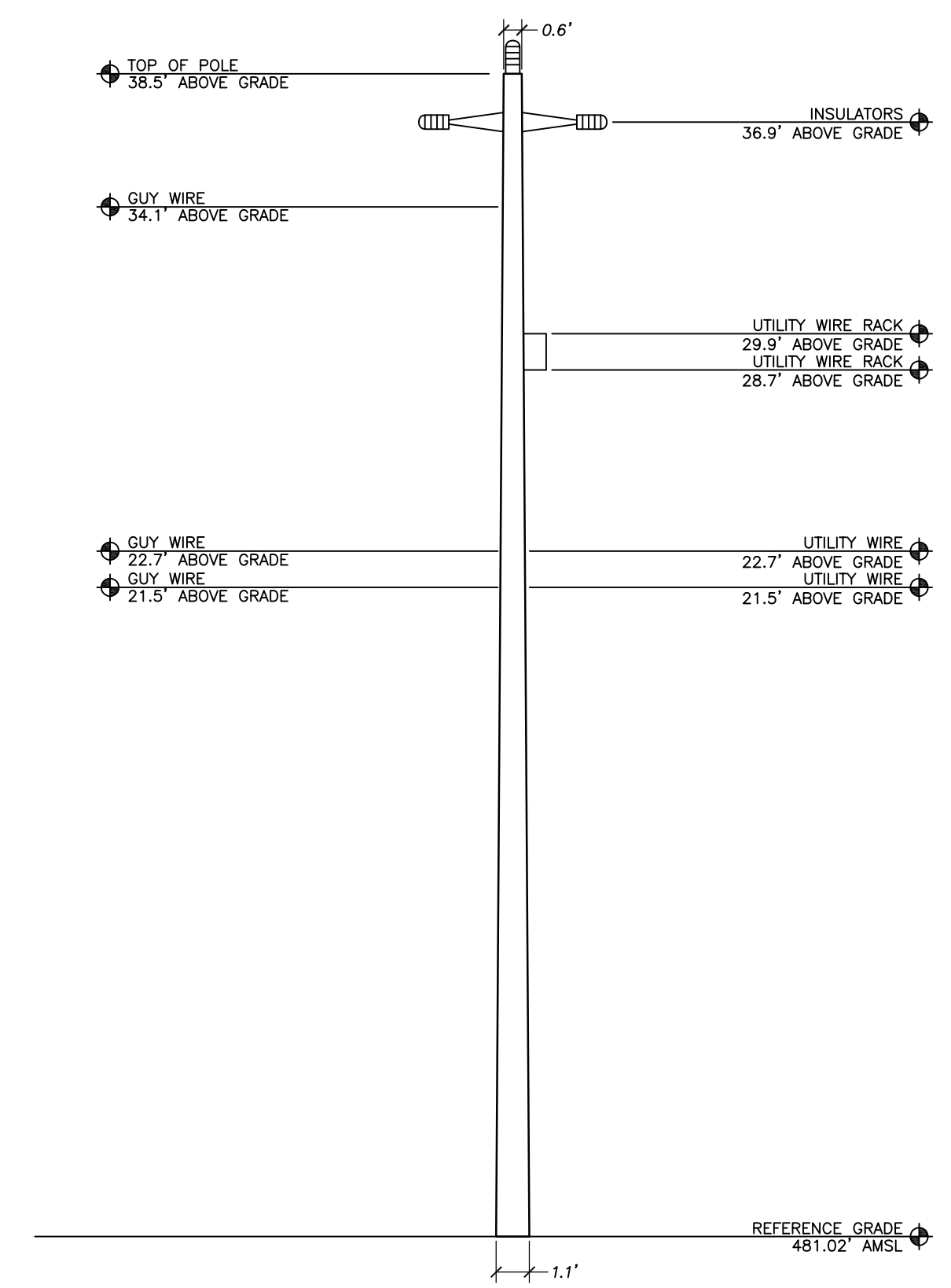

3 UTILITY POLE ELEVATION  
SCALE: 1"=5'

**BOUNDARY AND TITLE INFORMATION**

THIS MAP IS A GRAPHIC DEPICTION OF DATA COMPILED FROM MAPS AND VARIOUS OTHER INFORMATION. IT IS NOT A BOUNDARY SURVEY. THIS MAP IS A TOPOGRAPHIC MAP SHOWING PROPERTY LINES PLOTTED FROM SAID RECORD DATA AND BEST FIT ONTO EXISTING IMPROVEMENTS. THE LIMITS OF TOPOGRAPHIC DATA AND/OR IMPROVEMENTS GATHERED AND DEPICTED ARE LIMITED TO THE CONTRACTUAL SCOPE FOR THIS PROJECT. NO MONUMENTS WERE SET OR WILL BE SET. NO TITLE RESEARCH WAS PERFORMED BY OMNI DESIGN GROUP INC. PROPERTY LINE LOCATION COULD POSSIBLY SHIFT FROM LOCATIONS SHOWN HEREON SHOULD A BOUNDARY SURVEY BE PERFORMED. LOCATIONS OF EXISTING FEATURES RELATIVE TO PROPERTY LINES THEREFORE ARE APPROXIMATE.

**DATUM:**  
HORIZONTAL & VERTICAL DATUMS SHOWN ON THESE PLANS WERE OBTAINED FROM GPS OBSERVATIONS USING CALIFORNIA REAL TIME NETWORK "CRTN".

**BASIS OF BEARINGS**  
THE BEARINGS ARE BASED UPON CALIFORNIA COORDINATE SYSTEM, ZONE 3, NAD 83

**BENCHMARK:**  
THE ELEVATIONS ARE BASED UPON NAVD 88

- NOTES:**
- DATE OF SURVEY: 08/23/17
  - NO UNDERGROUND UTILITIES WERE LOCATED.
  - ADDRESS(S) AND ASSESSOR PARCEL NUMBER(S) "APN" WERE OBTAINED USING THE COUNTY OF SAN MATEO'S GIS WEBSITE. OMNI DESIGN GROUP, INC. ASSUMES NO LIABILITY FOR INFORMATION OBTAINED.

- LEGEND**
- AC = ASPHALTIC CONCRETE
  - EP = EDGE OF PAVEMENT
  - FL = FLOWLINE
  - FS = FINISHED SURFACE
  - GD = GROUND ELEVATION
  - TC = TOP OF CURB
  - AGL = ABOVE GRADE LEVEL
  - AMSL = ABOVE MEAN SEA LEVEL

1 BOUNDARY & LEGAL DESCRIPTIONS  
SCALE: NONE



PROJECT INFORMATION:  
SF BURLINGAME 018  
VERIZON SITE #438509  
138 VALDEFLORES DR  
BURLINGAME, CA

CURRENT ISSUE DATE:  
10/19/17

ISSUED FOR:  
100% SURVEY

REV. DATE	DESCRIPTION	BY

COORDINATING ARCHITECT:  
  
 Architecture  
 Civil Engineering  
 Surveying  
 Telecommunications  
 711 Tank Farm Road, Suite 100  
 San Luis Obispo, California 93401  
 Phone: (805) 544-9700  
 www.omnidesigngroup.com  
 email: omni@odgso.com

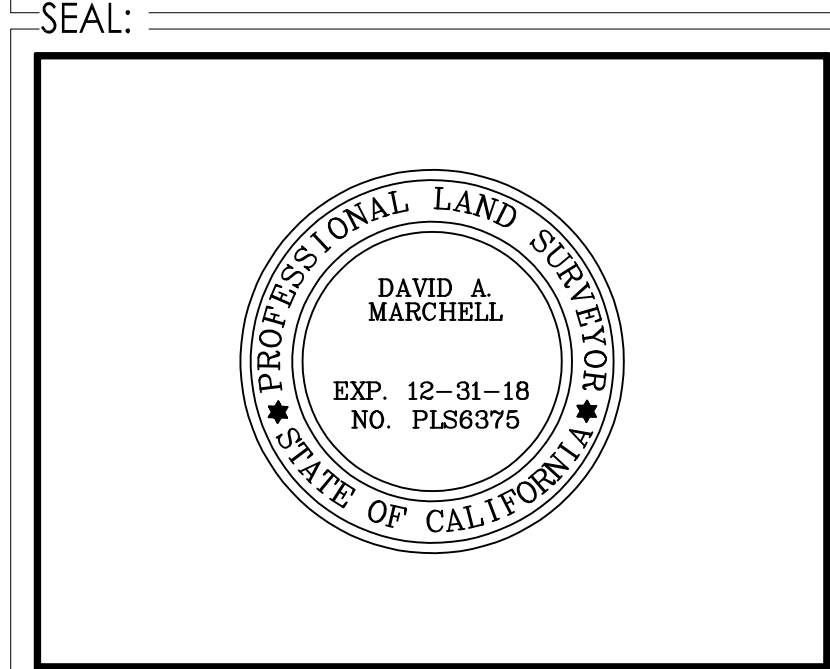

CONSULTANT:  
  
 Modus, Inc.  
 240 Stockton Street, 3rd Floor  
 San Francisco, CA 94108

DRAWN BY: \_\_\_\_\_ CHK.: \_\_\_\_\_ APV.: \_\_\_\_\_  
 AK/DKN    DM    DM

SHEET TITLE:  
SITE PLAN

SHEET NUMBER: \_\_\_\_\_ REVISION: \_\_\_\_\_  
**C-1**  
 1180-100



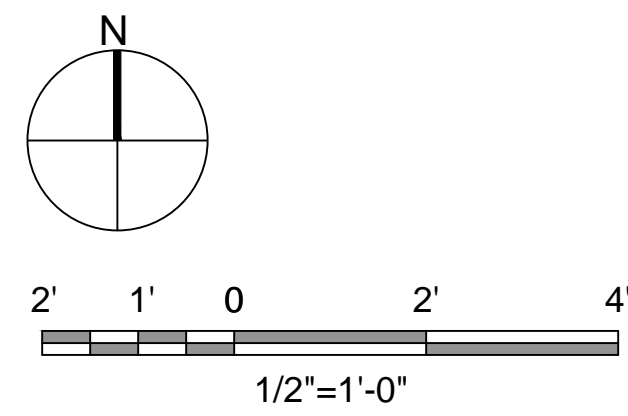
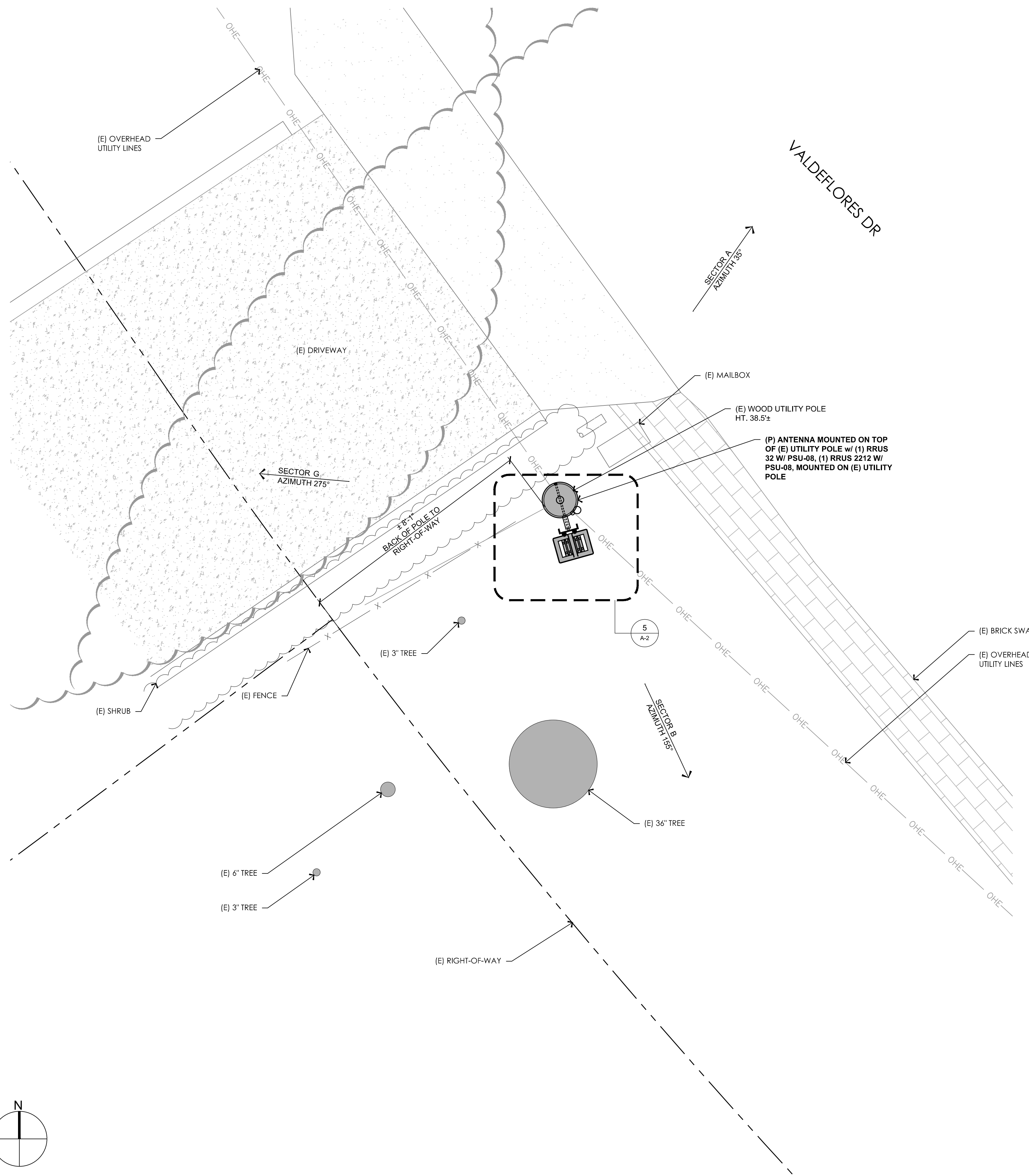

17 ENLARGED SITE PLAN  
1/2"=1'-0"

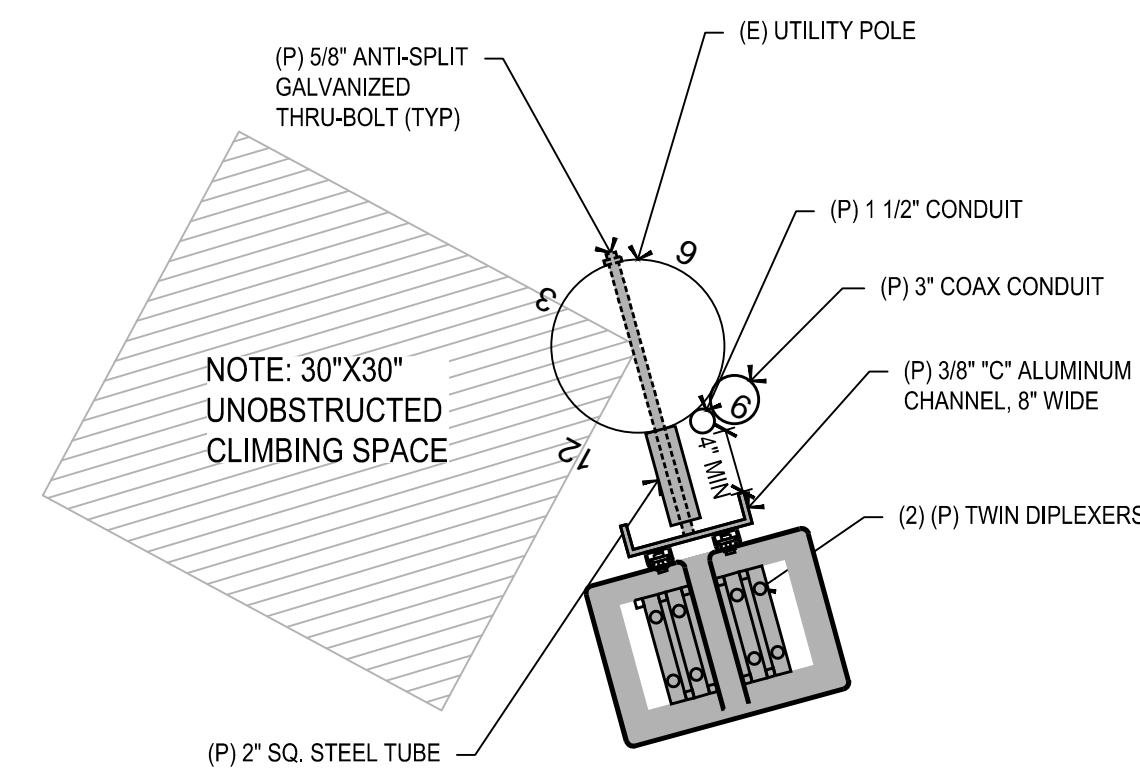

8 SHROUD MOUNTING DETAIL  
1"=1'-0"

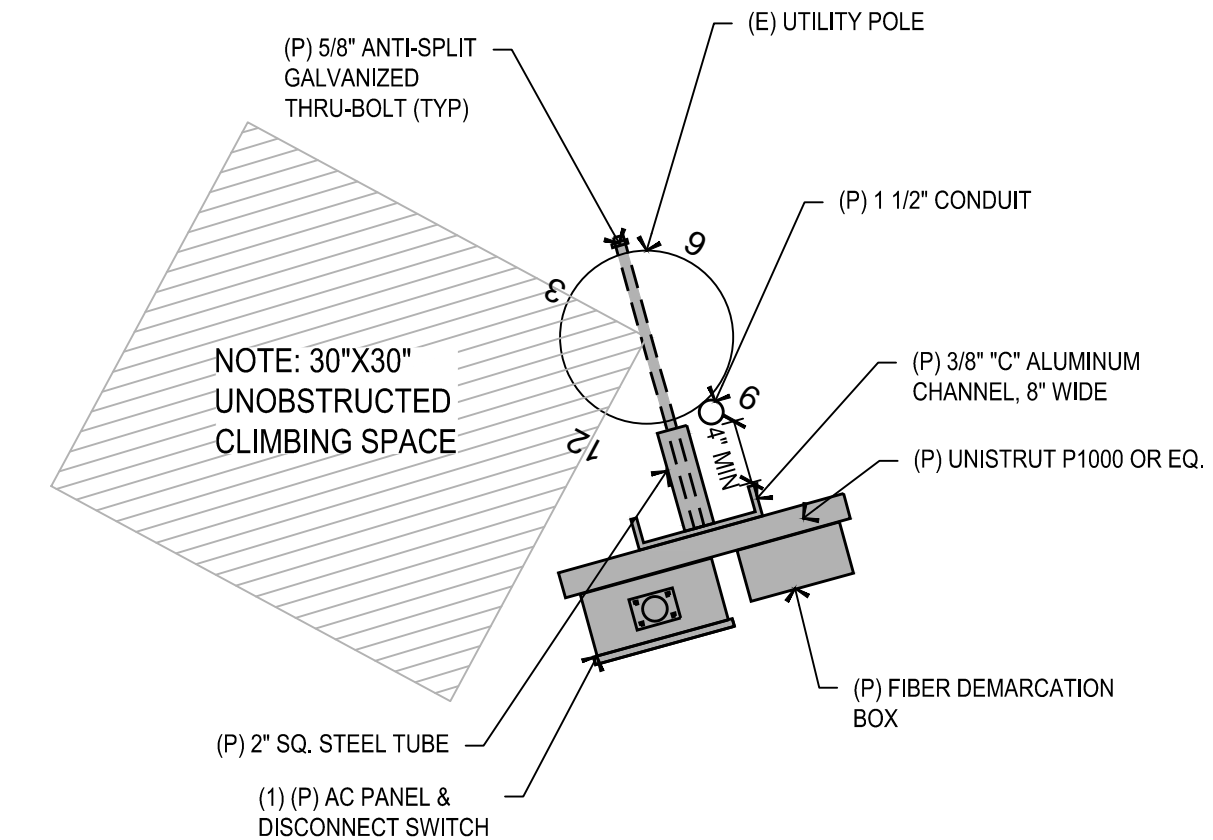

4 LOAD CENTER AND PANEL MOUNTING DETAIL  
1"=1'-0"

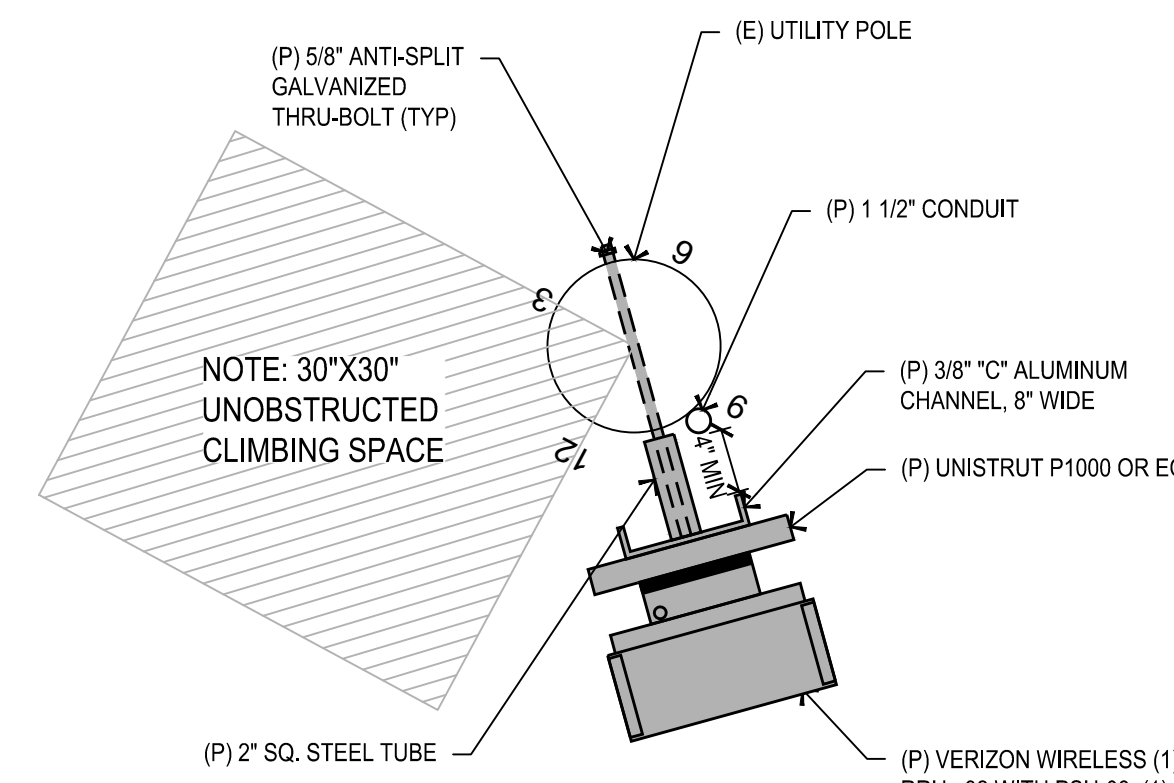

7 RRU MOUNTING DETAIL  
1"=1'-0"

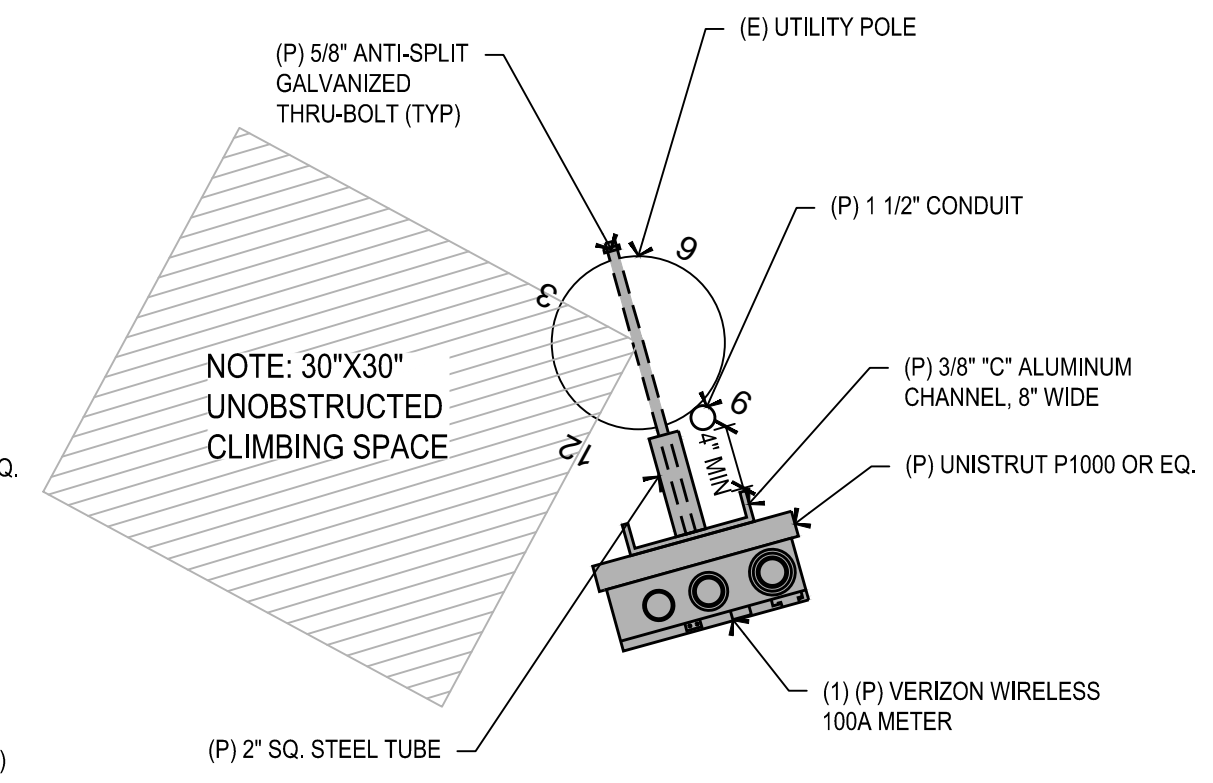

3 POWER METER MOUNTING DETAIL  
1"=1'-0"

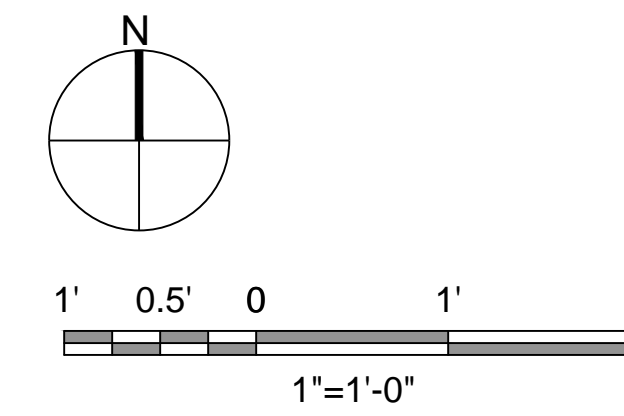
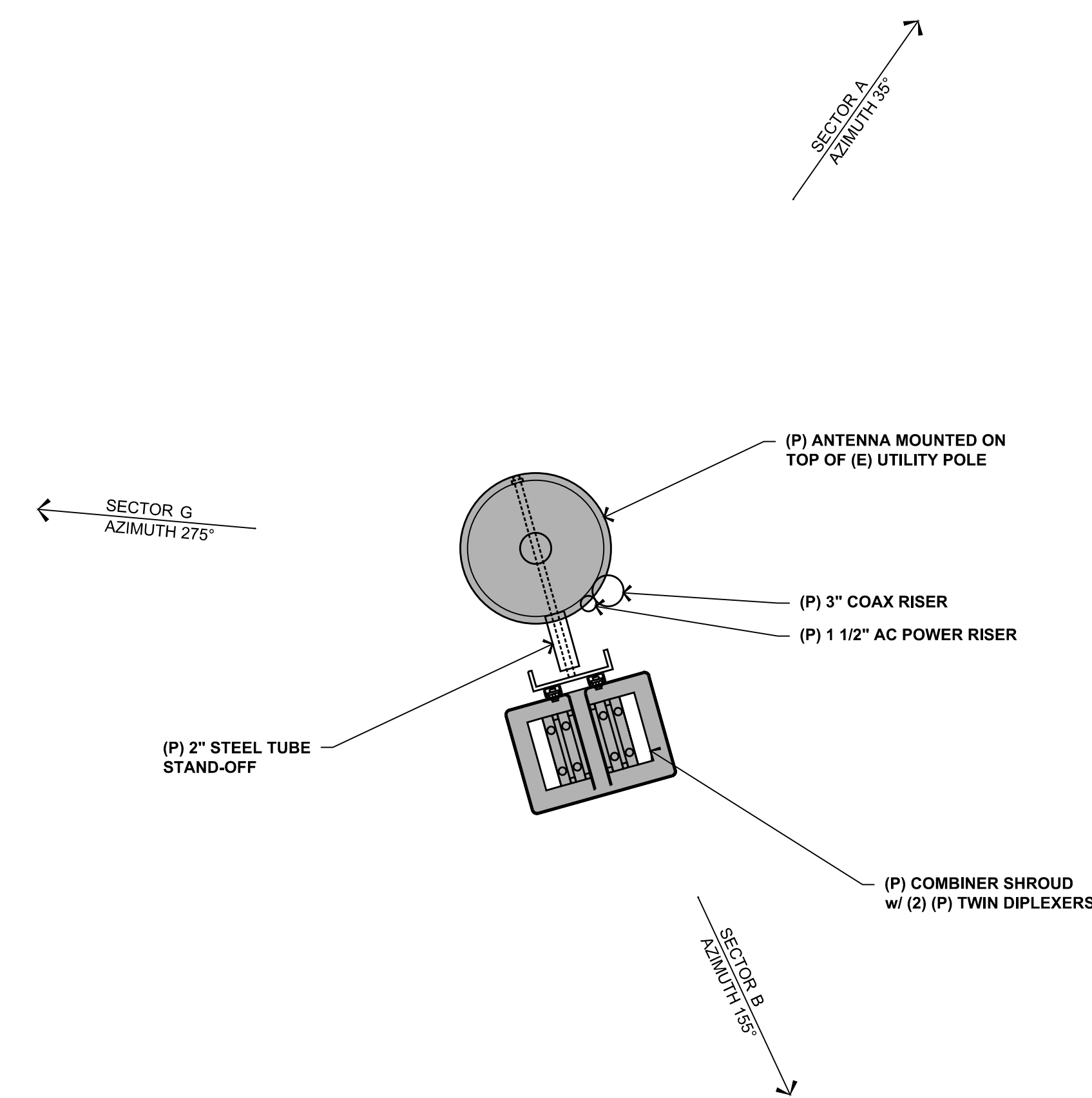

5 ENLARGED ANTENNA PLAN  
1"=1'-0"



REV	DATE	DESCRIPTION
1	02/21/18	90% CD SUBMITTAL
0	10/24/17	90% CD SUBMITTAL

SITE NUMBER:

**BUR\_018**

SITE ADDRESS:  
138 VALDEFLORES DR  
BURLINGAME, CA 94010

STAMP

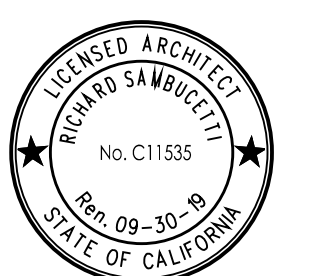

DRAWN BY: D.A.G. PROJECT NO.: T-16519-48

CHECK BY: B.K.W.

SHEET TITLE

ENLARGED SITE  
PLAN & ANTENNA  
PLAN

SHEET NO.



REV	DATE	DESCRIPTION
1	02/21/18	90% CD SUBMITTAL
0	10/24/17	90% CD SUBMITTAL

SITE NUMBER:

**BUR\_018**

SITE ADDRESS:  
138 VALDEFLORES DR  
BURLINGAME, CA 94010

STAMP

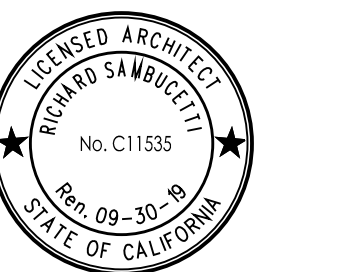

DRAWN BY: D.A.G. PROJECT NO.: T-16519-48

CHECK BY: B.K.W.

SHEET TITLE

ELEVATIONS

SHEET NO.

**A-3**

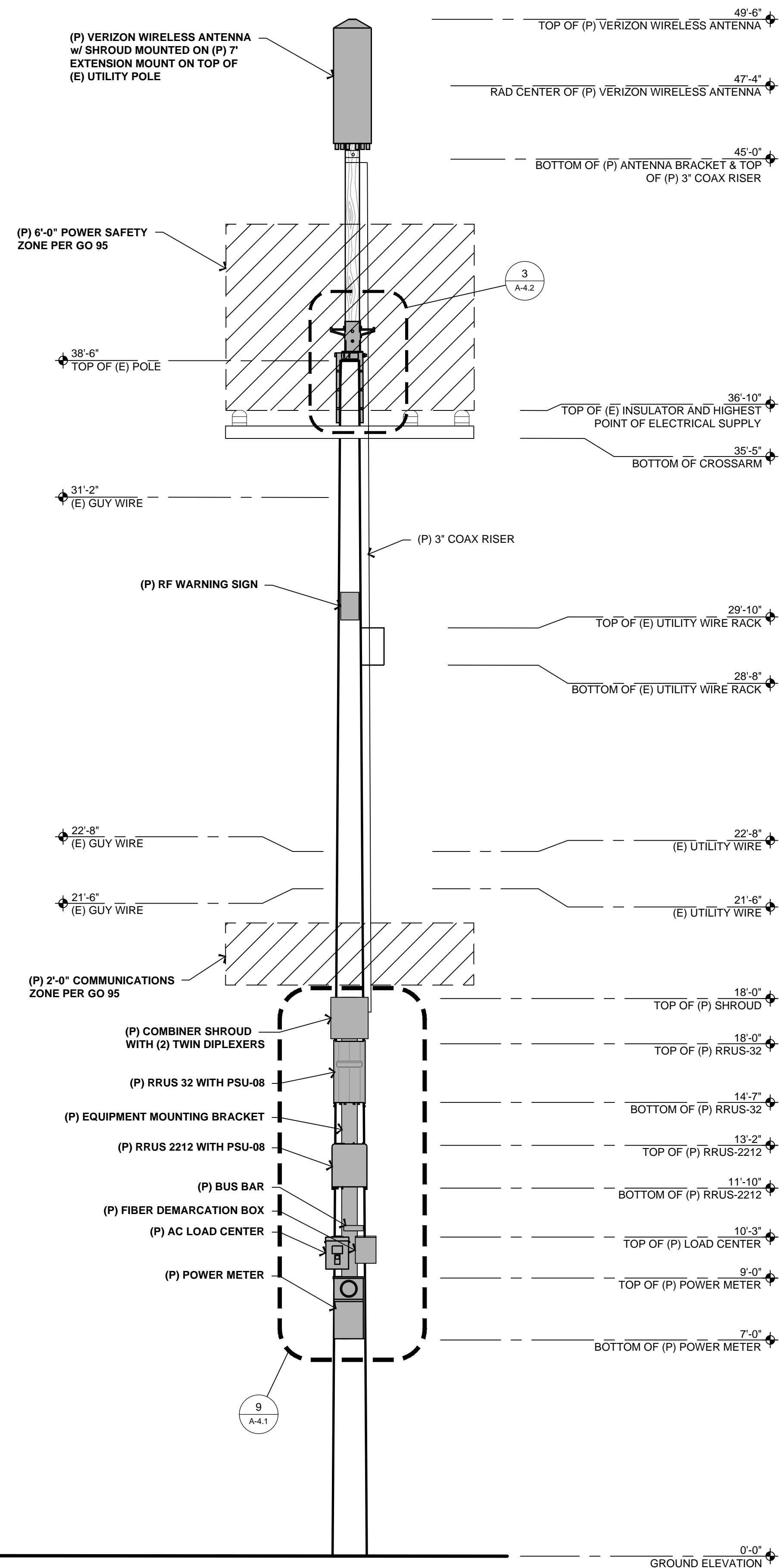
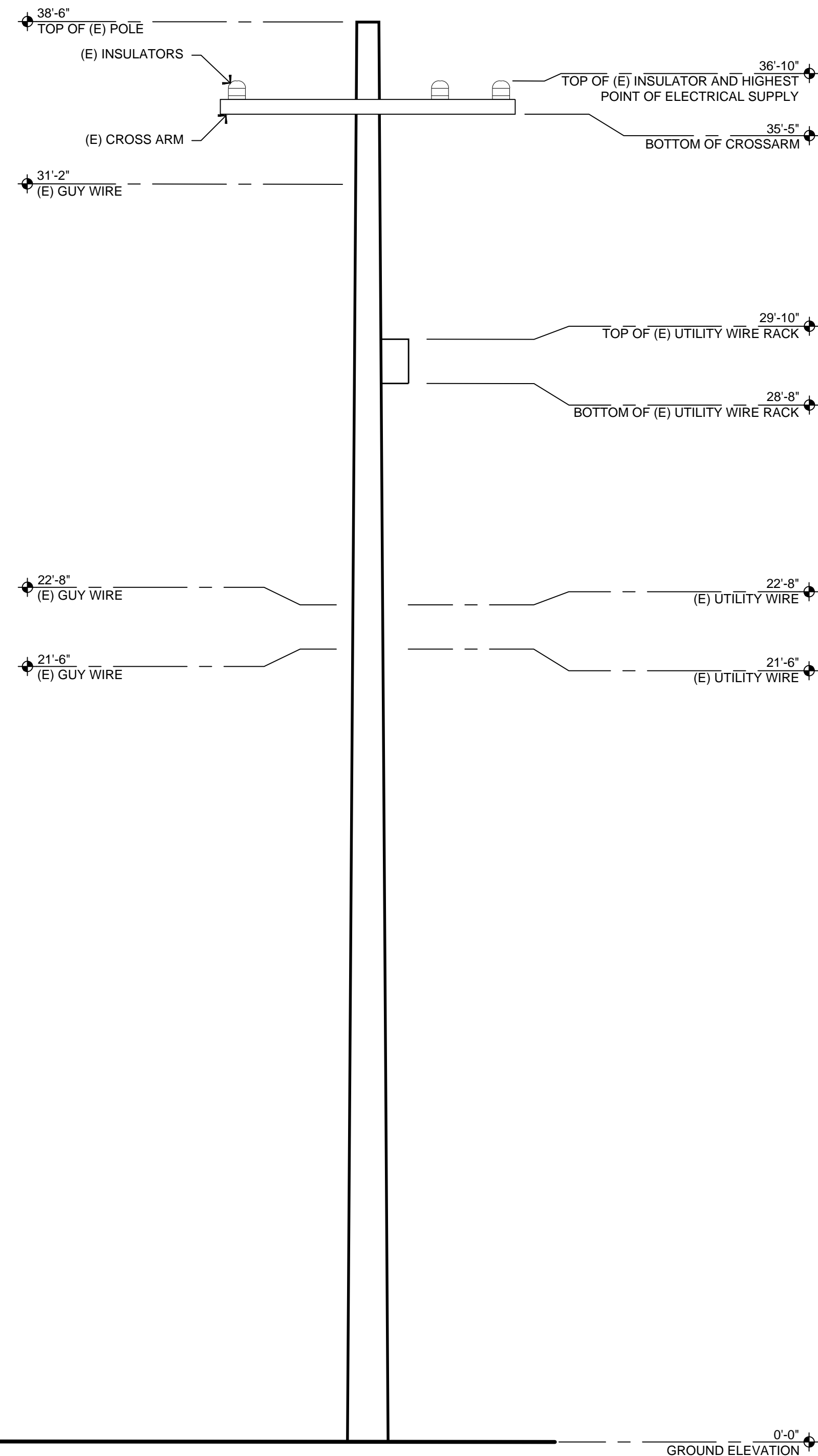

**ERICSSON RRU-32 WITH PSU-08**

MODEL: RRU 32 WITH PSU-08  
 COLOR: WHITE  
 DIMENSIONS: 26.7" TALL X 12.1" WIDE X 6.7" DEEP (INCLUDING SUNSHIELD)  
 WEIGHT: +/- 80.4 LBS. (INCLUDING MOUNTING HARDWARE)

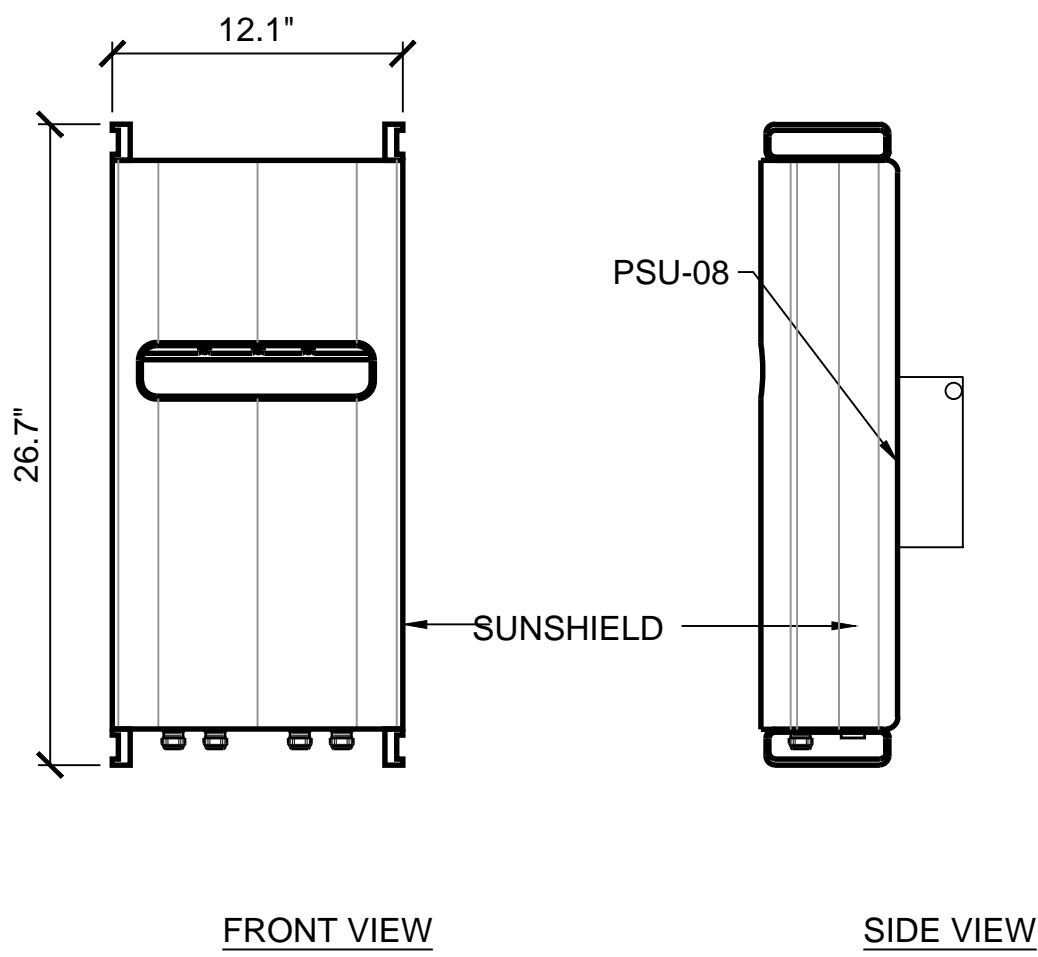
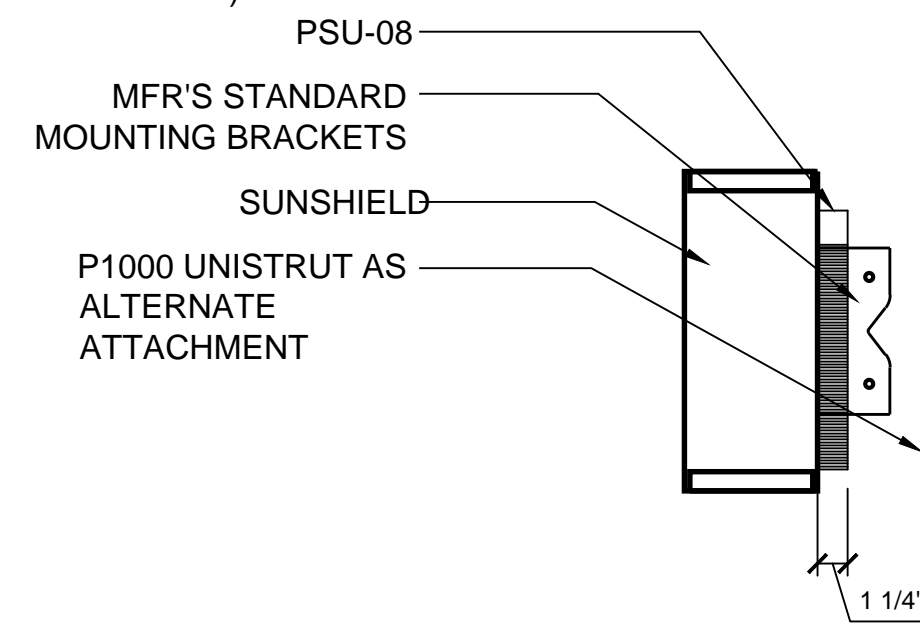

**19 RRU 32 WITH PSU-08 MOUNTING DETAIL**  
 1 1/2" = 1'-0"

**METER MAKE AND MODEL:**  
 MODEL: U21MTBL  
 DIMENSIONS, HxWxD.in: 24" x 12.05" x 4"  
 COLOR: GRAY  
 NEUTRAL CONDUCTOR: 14 AWG-2/0 AWG  
 HUB PROV: AW  
 SERVICE TYPE: 4  
 VOLTAGE: 600  
 AMPACITY: 100 MAX/ 100 CONT.  
 BRANCH CIRCUITS: NONE  
 CONSTRUCTION TYPE: 3R CONSTRUCTION

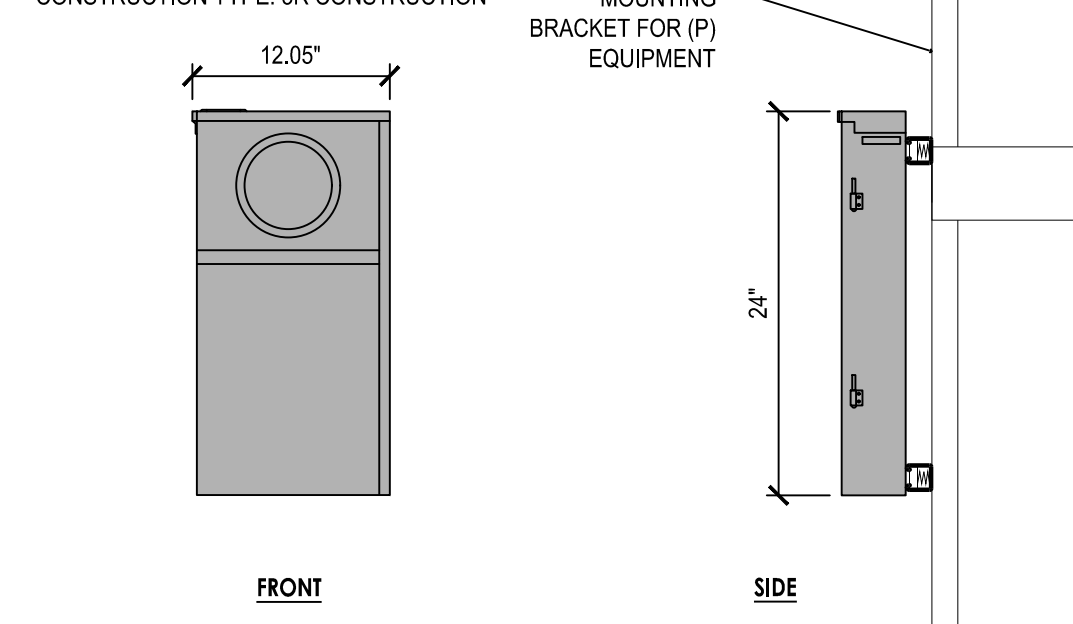

**16 POWER METER DETAIL**  
 1" = 1'-0"

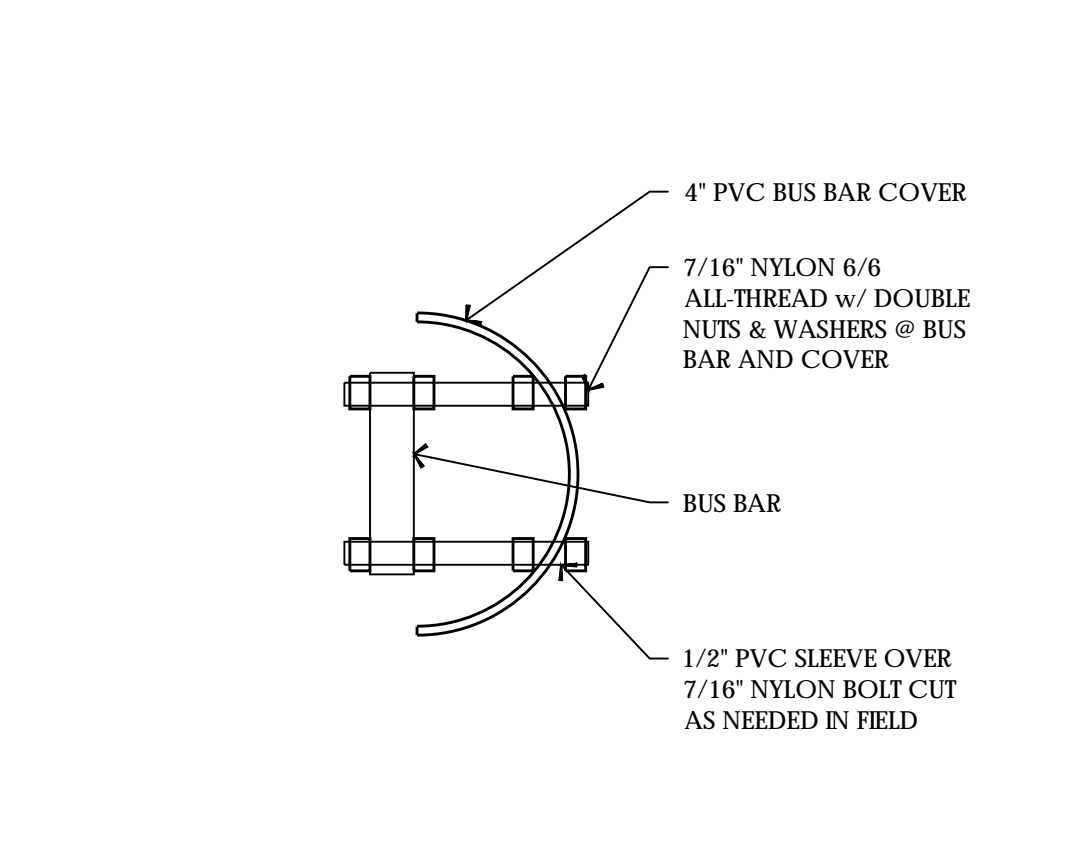

**15 BUS BAR COVER**  
 NOT TO SCALE

**ELEC LOAD CENTER MAKE AND MODEL:**  
 MANUFACTURER: SQUARE D  
 MODEL: QO612L100RB  
 DIMENSIONS, HxWxD.in: 12.64" x 8.9" x 4.27"  
 WEIGHT: 9.7 lbs

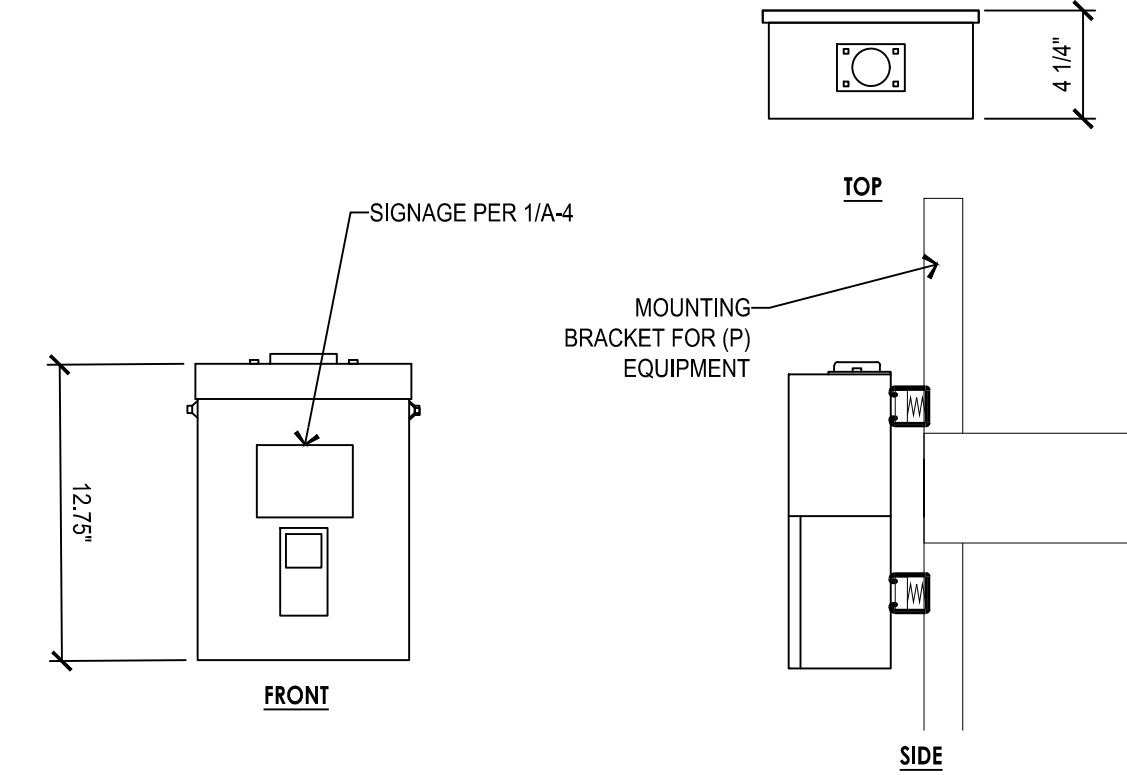

**12 AC ELEC LOAD CENTER DETAIL**  
 1 1/2" = 1'-0"

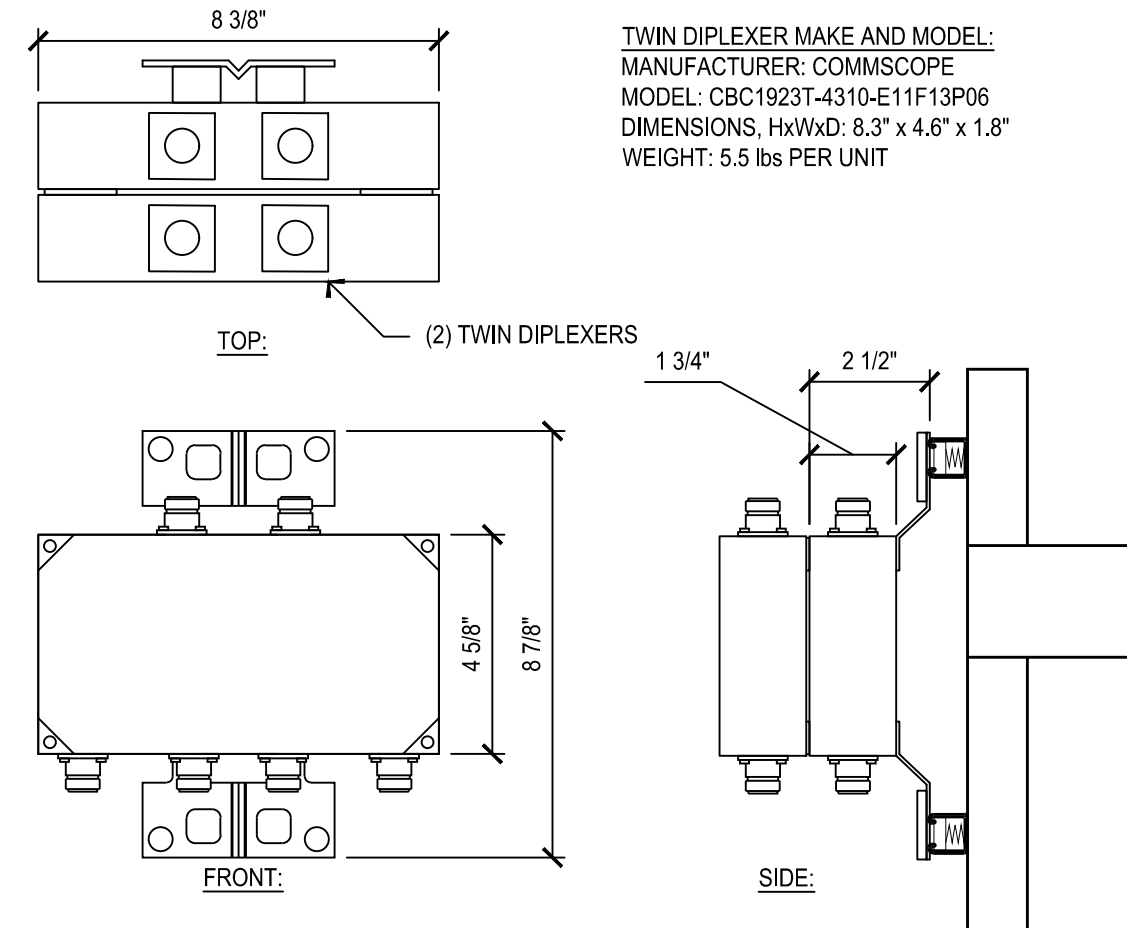

**11 TWIN DIPLEXER DETAIL**  
 3" = 1'-0"

**ERICSSON RRU 2212**

MODEL: RRU 2212  
 COLOR: WHITE  
 DIMENSIONS: 16.54" TALL X 12.6" WIDE X 13.47" DEEP (INCLUDING SUNSHIELD)  
 WEIGHT: +/- 82 LBS. (INCLUDING MOUNTING HARDWARE)

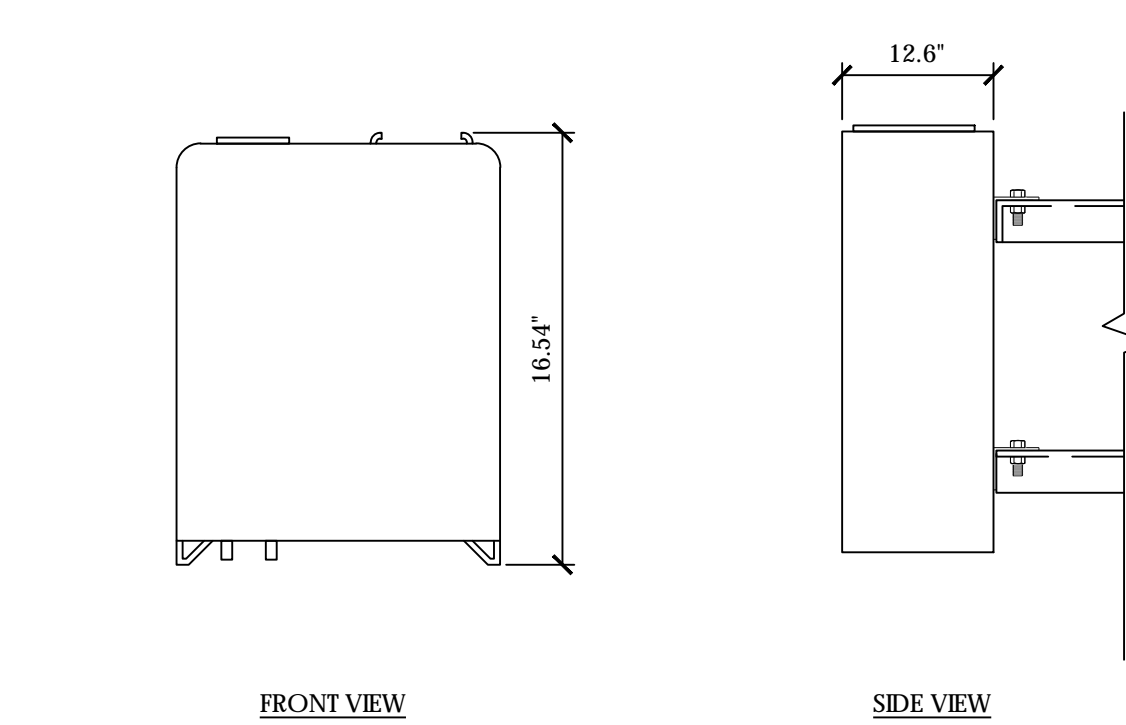
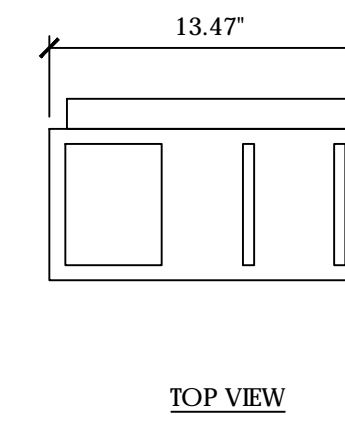

**7 ERICSON RRU 2212**  
 1 1/2" = 1'-0"

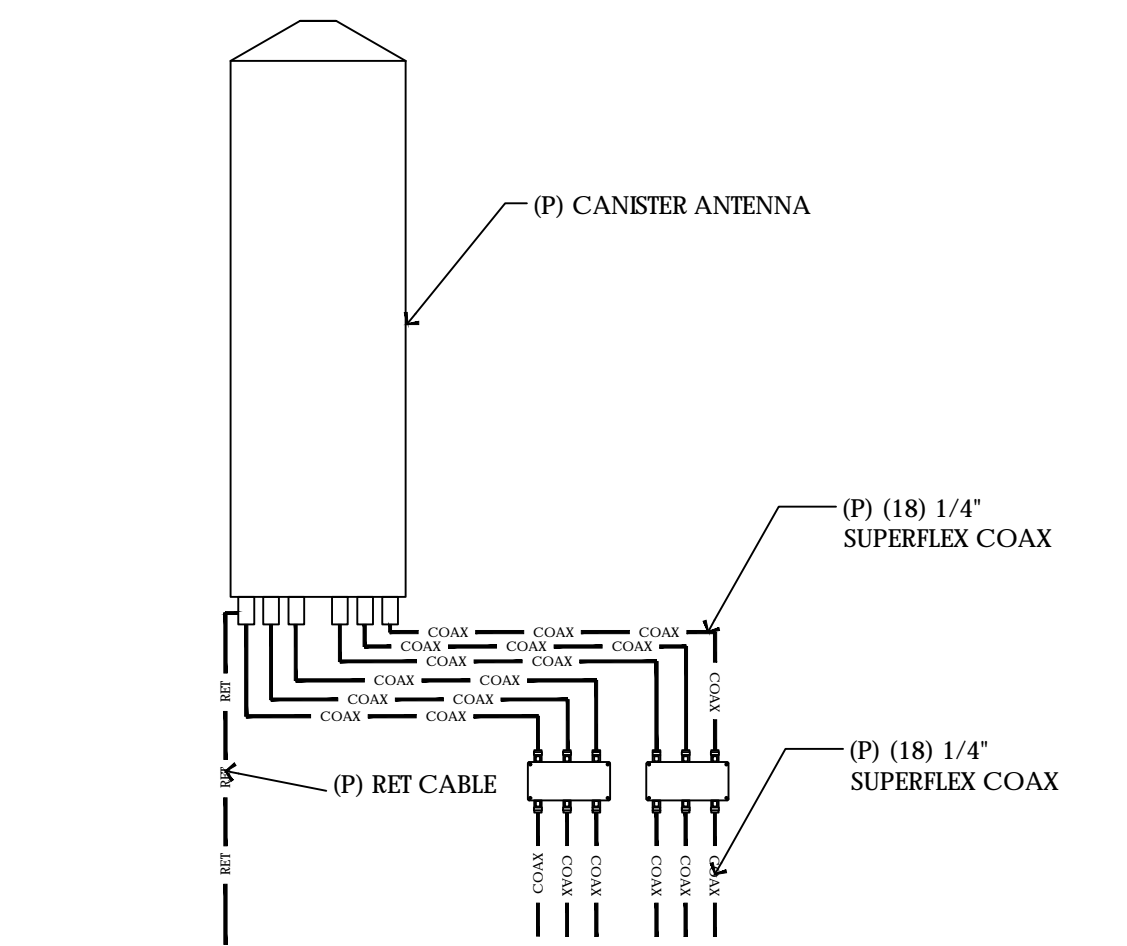

**4 WIRE DIAGRAM**  
 3/4" = 1'-0"

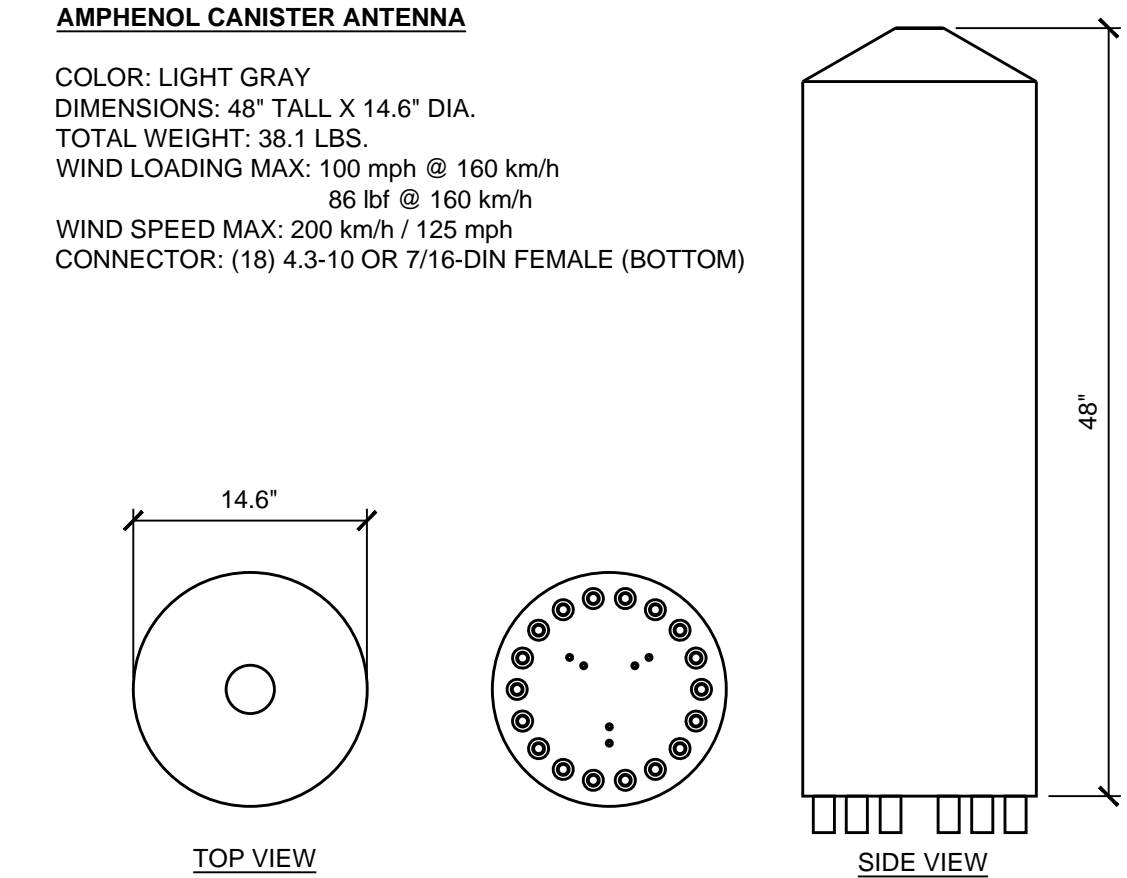

**3 AMPHINOL CANISTER ANTENNA**  
 1" = 1'-0"

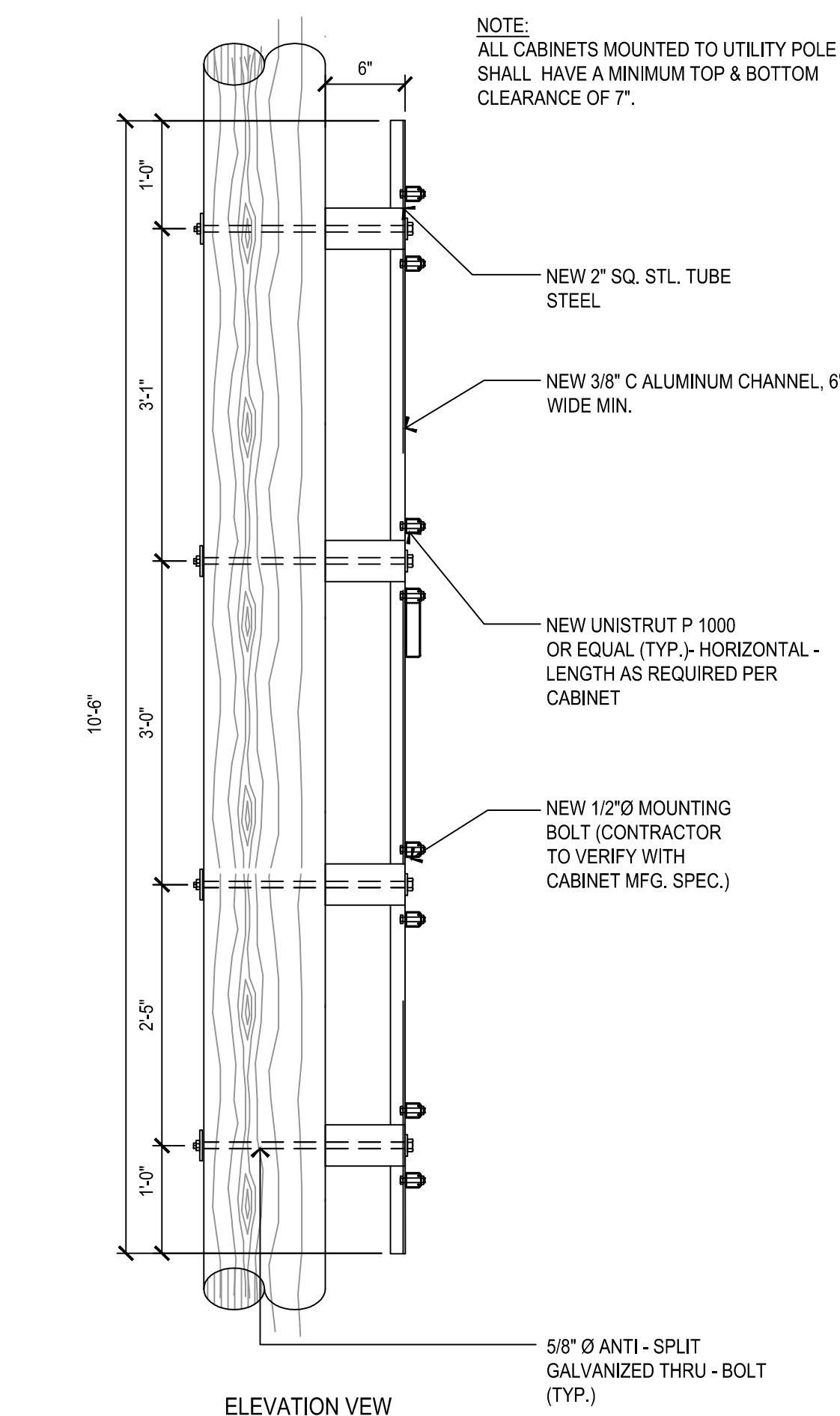

**17 EQUIPMENT MOUNTING DETAIL**  
 3/4" = 1'-0"

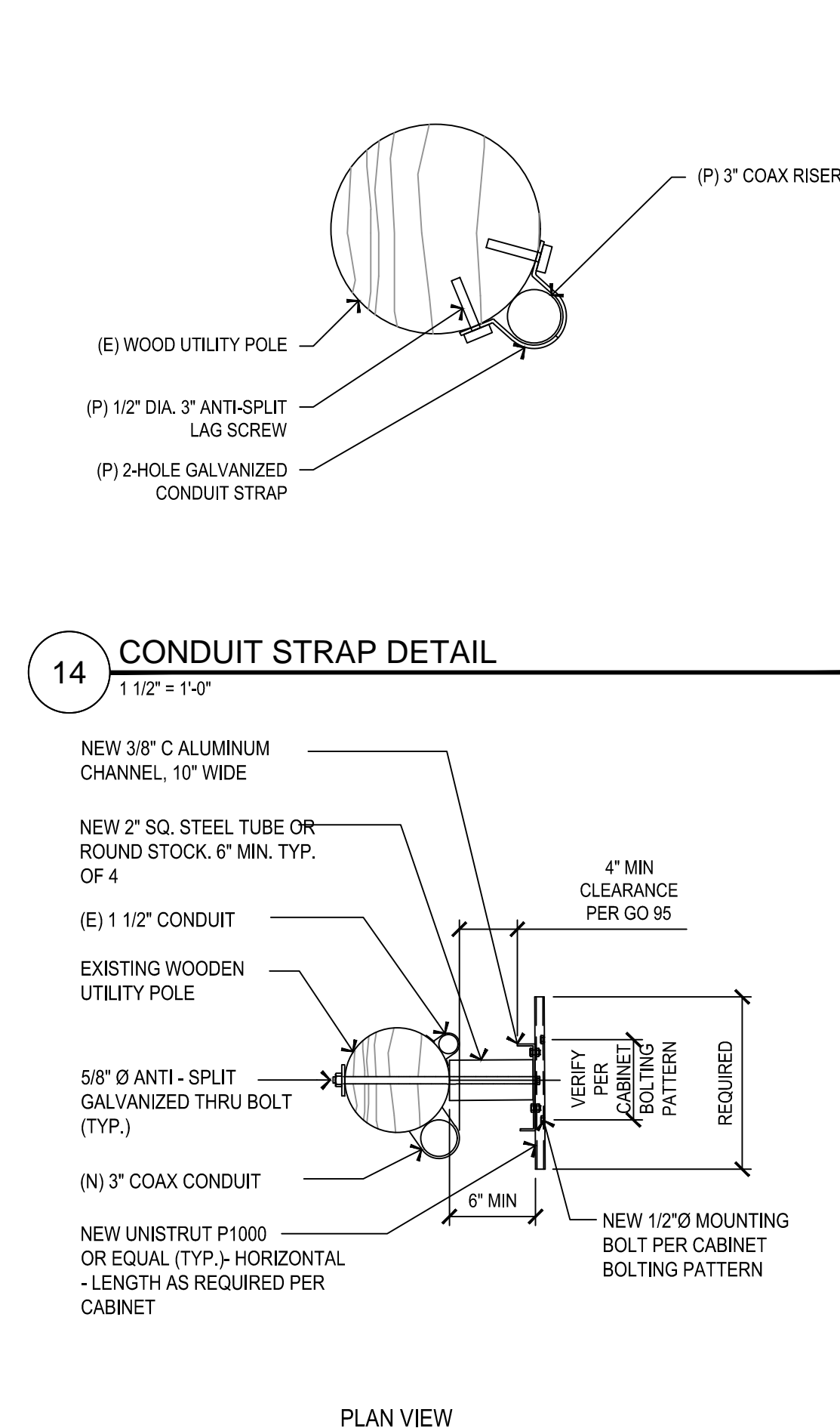

**14 CONDUIT STRAP DETAIL**  
 1 1/2" = 1'-0"

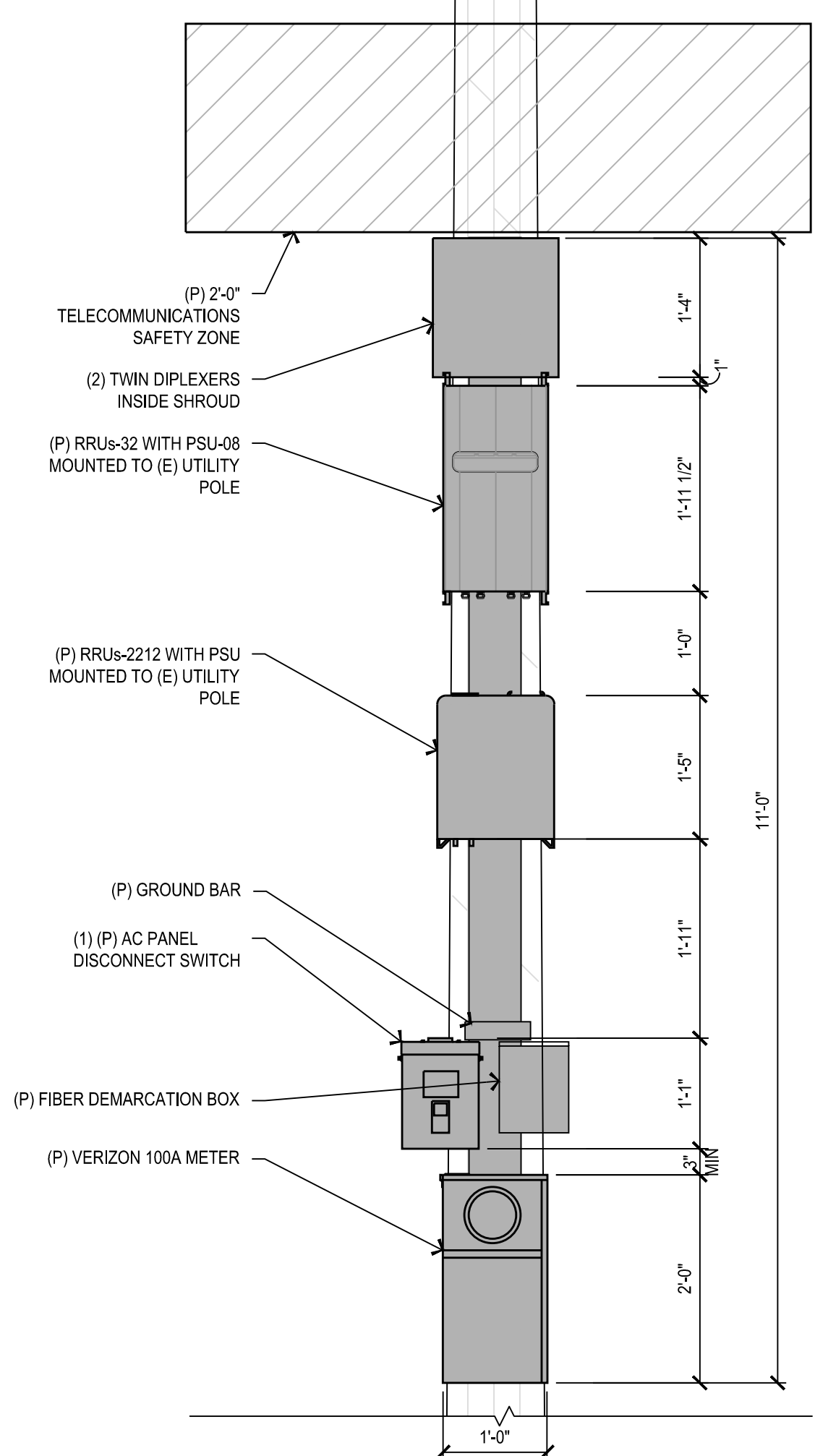

**9 ANTENNA EQUIPMENT FRONT ELEVATION**  
 3/4" = 1'-0"

**NOTE:**  
 SIGN BACKGROUND COLOR TO MATCH (E) POLE  
 ALL TEXT AND SYMBOLS TO BE WHITE

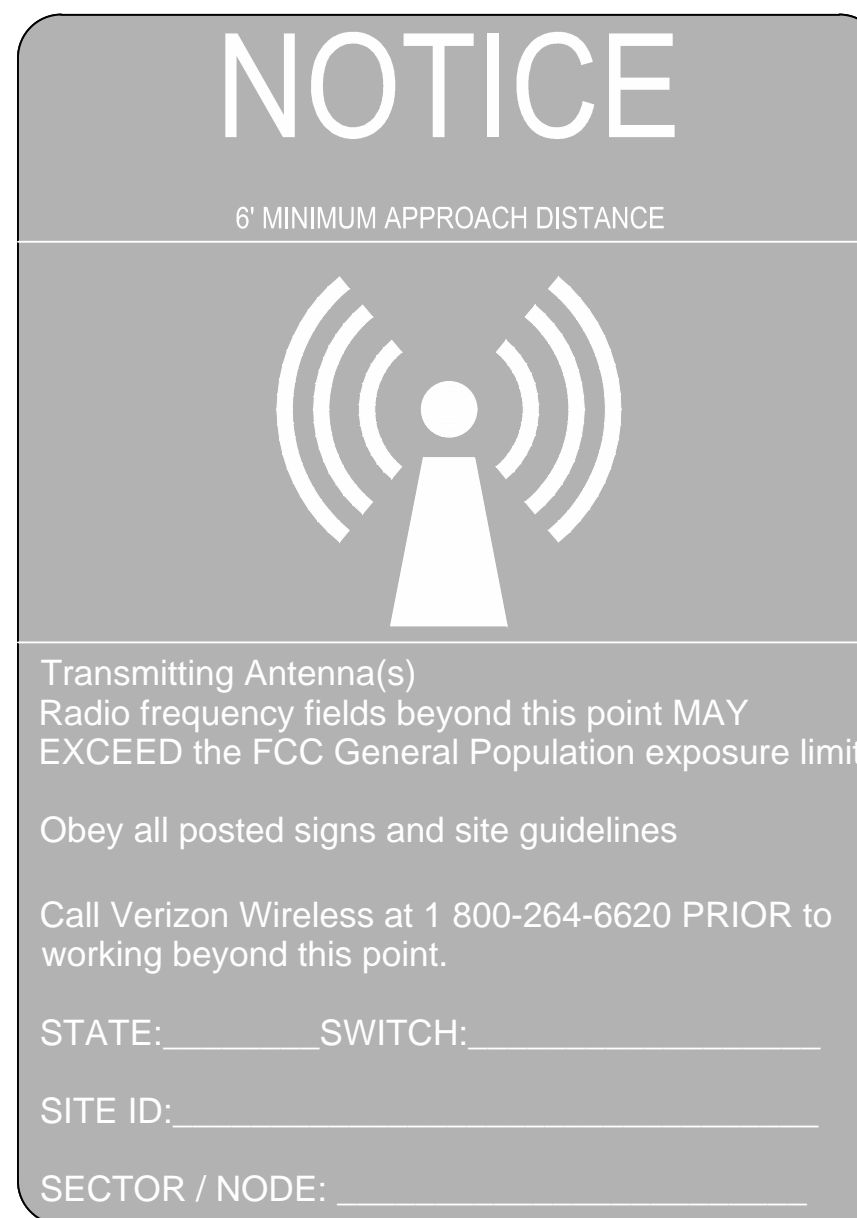

**5 NOTICE SIGNAGE**  
 1" = 1'-0"

**NOTE:**  
 1. INSIDE AND OUTSIDE PANEL DOOR SHOWING SHUT-DOWN PROTOCOL ON 3"x4" LABEL  
 2. SITE ID WIL LBE SWITCH #, SITE #, & SITE NAME  
 3. SIGN PROVIDED BY GC MOUNTED TO OUTSIDE OF SERVICE DISCONNECT

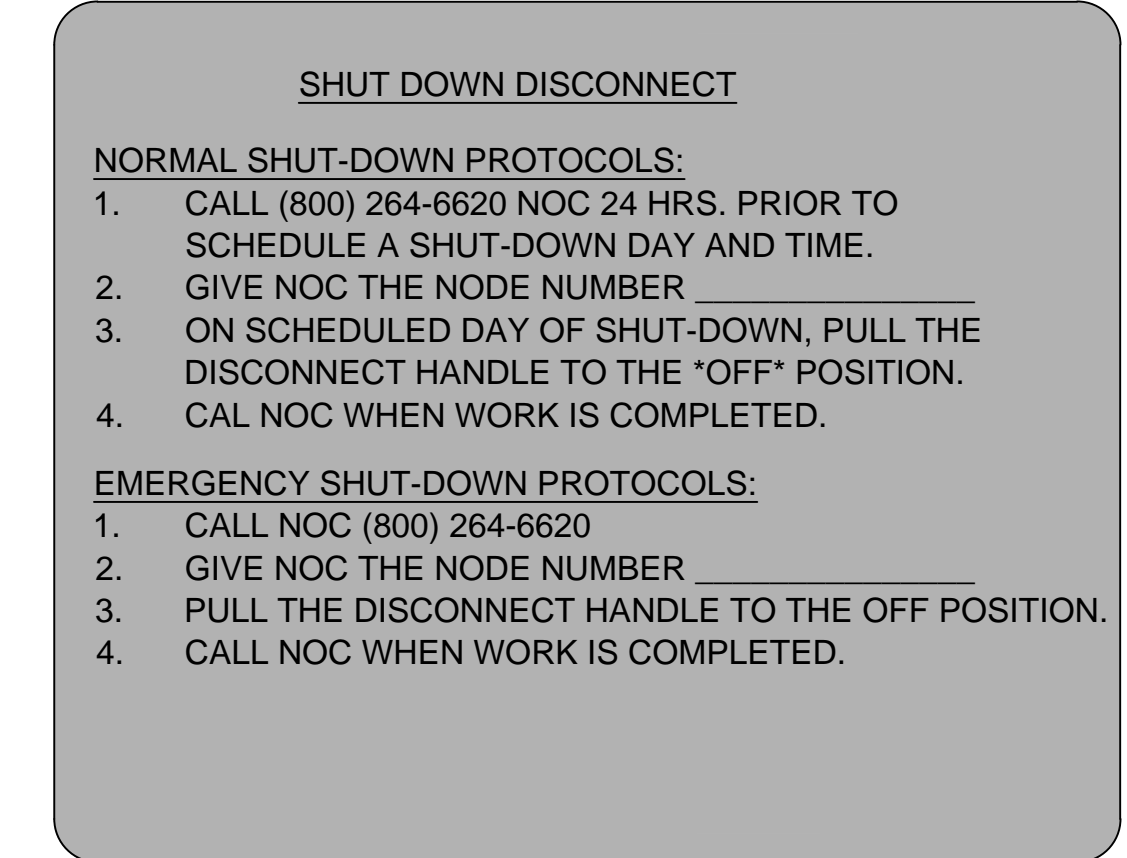

**1 SHUT DOWN PROTOCOL SIGNAGE**  
 1" = 1'-0"



2785 MITCHELL DRIVE, SUITE 9  
 WALNUT CREEK, CA 94598



modus-corp.com

240 STOCKTON STREET, 3RD FLOOR  
 SAN FRANCISCO, CA 94108



borgesarch.com

1478 STONE POINT DRIVE, SUITE 350  
 ROSEVILLE CA 95661  
 916 782 7200 TEL  
 916 773 3037 FAX

REV	DATE	DESCRIPTION
1	02/21/18	90% CD SUBMITTAL
0	10/24/17	90% CD SUBMITTAL

**SITE NUMBER:**

**BUR\_018**

**SITE ADDRESS:**  
 138 VALDEFLORES DR  
 BURLINGAME, CA 94010

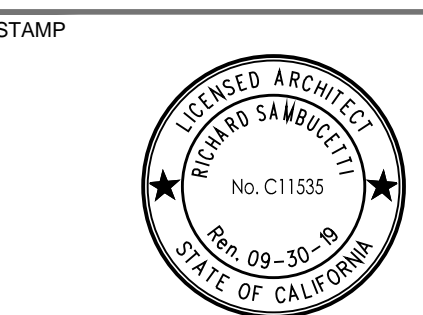

DRAWN BY: D.A.G. PROJECT NO.: T-16519-48  
 CHECK BY: B.K.W.  
 SHEET TITLE

**DETAILS**

SHEET NO.

**A-4.1**

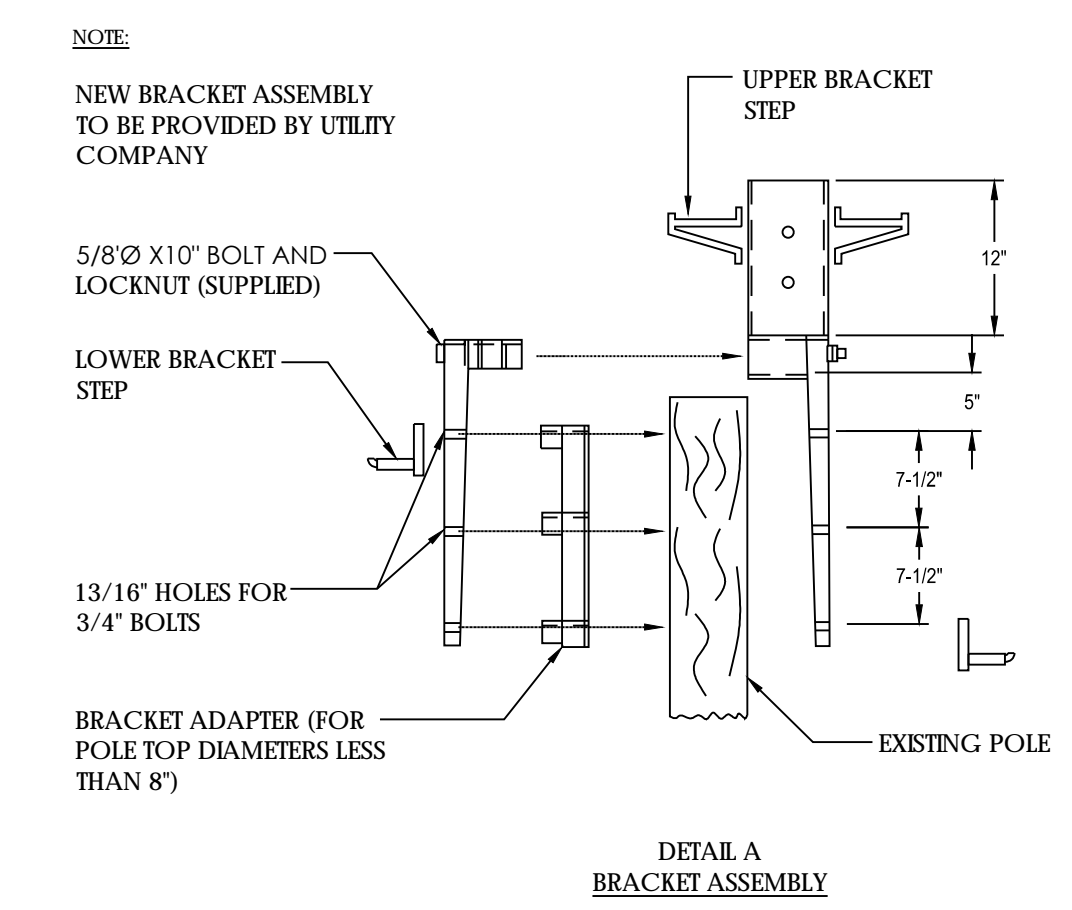
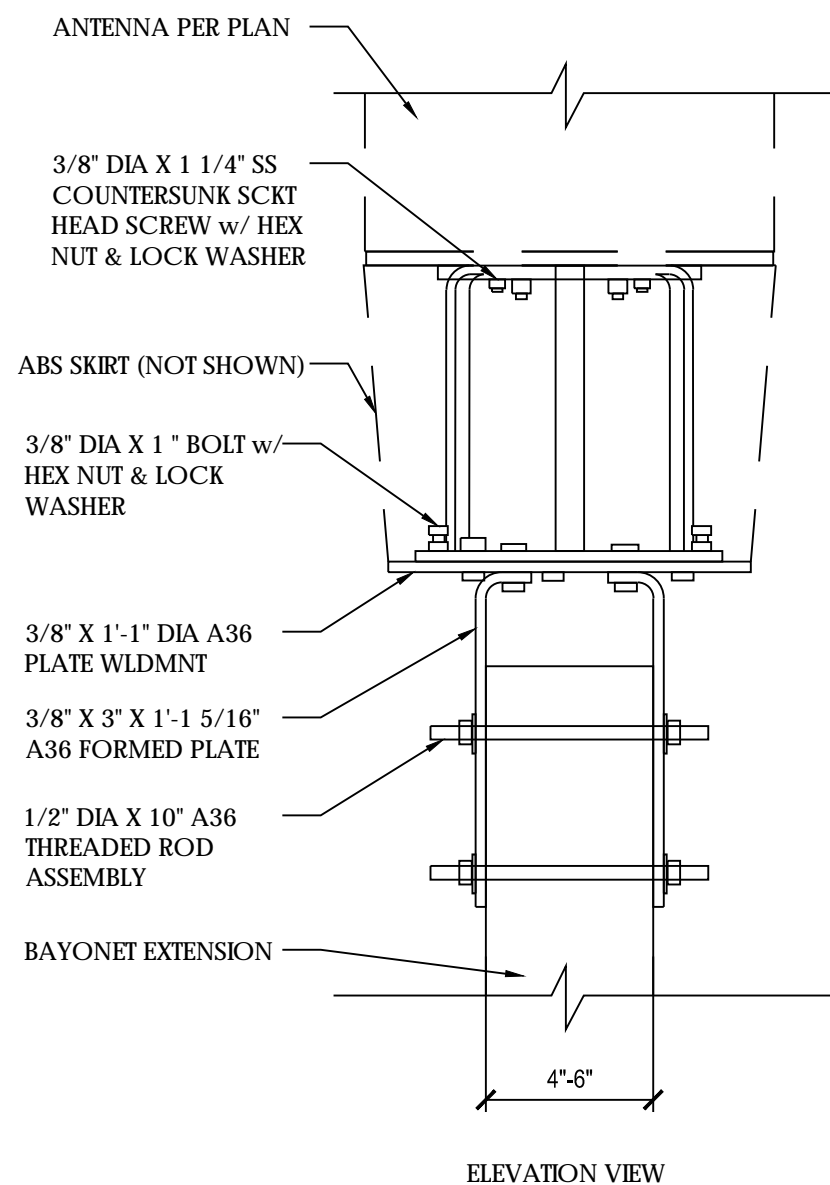

**ARIA NID-12 FIBER DEMARCATION BOX:**  
 MANUFACTURER: ARIA  
 MODEL: NID-12  
 DIMENSIONS (HxWxD): 8.54" x 10" x 2.88"

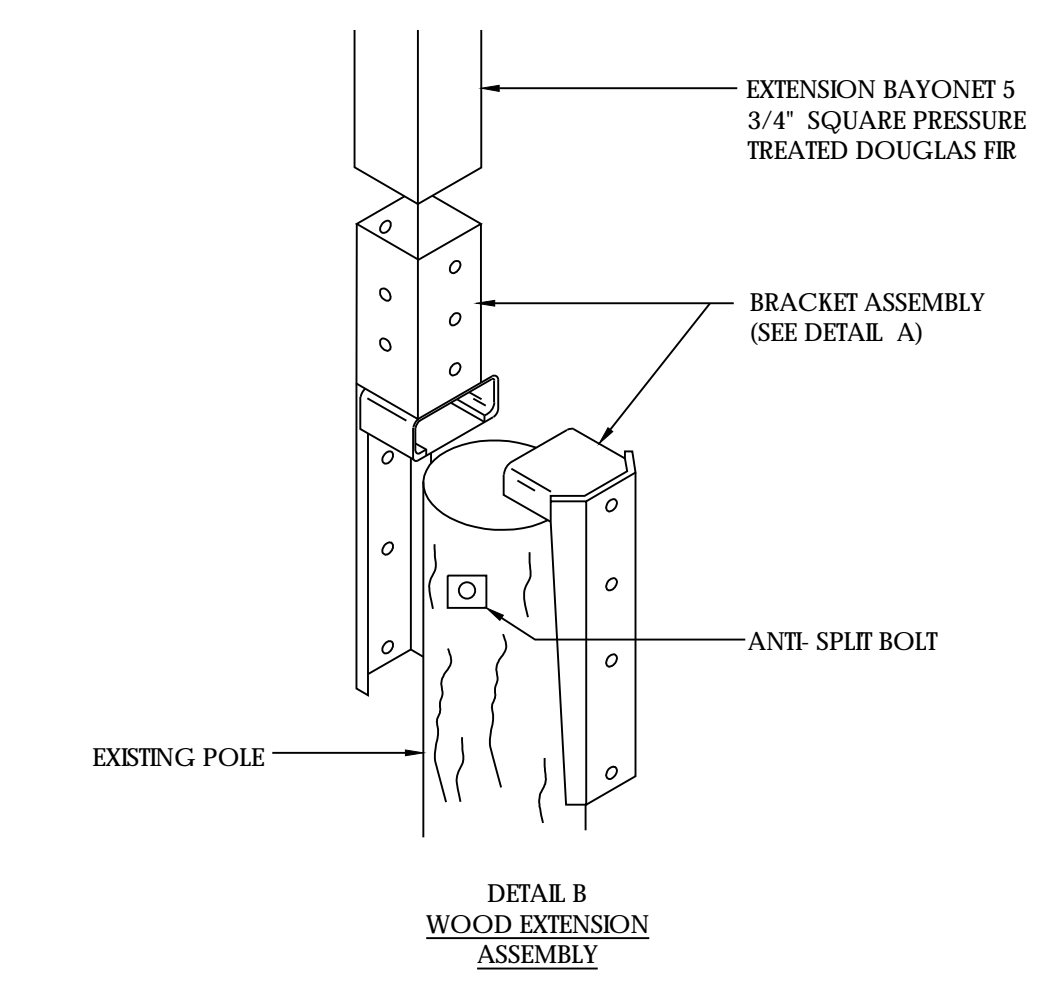
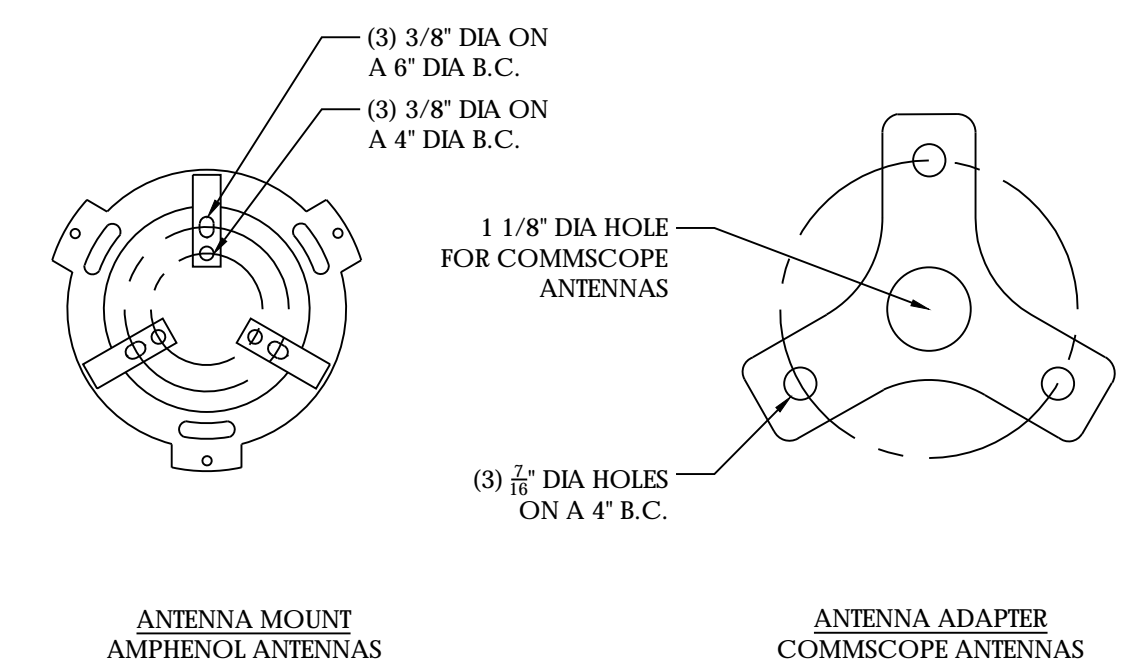
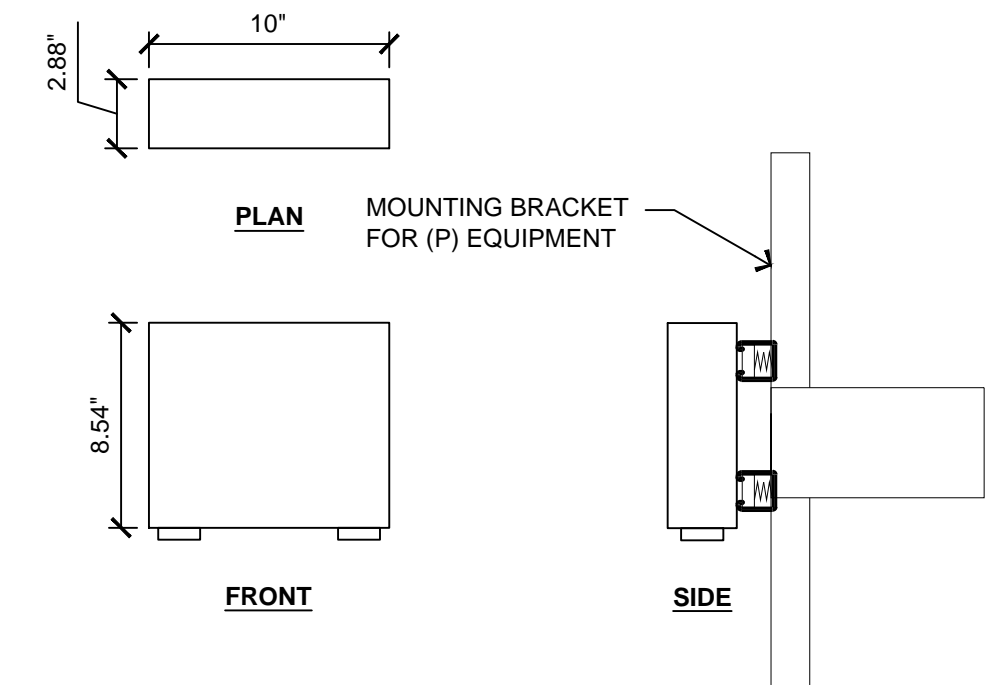

11 ARIA NID-12 FIBER DEMARCATION BOX  
 1 1/2" = 1'-0" rename me to this view "dwg" name

7 TOP MOUNT ANTENNA BRACKET  
 NOT TO SCALE

3 WOOD POLE EXTENSION  
 3/4" = 1'-0"

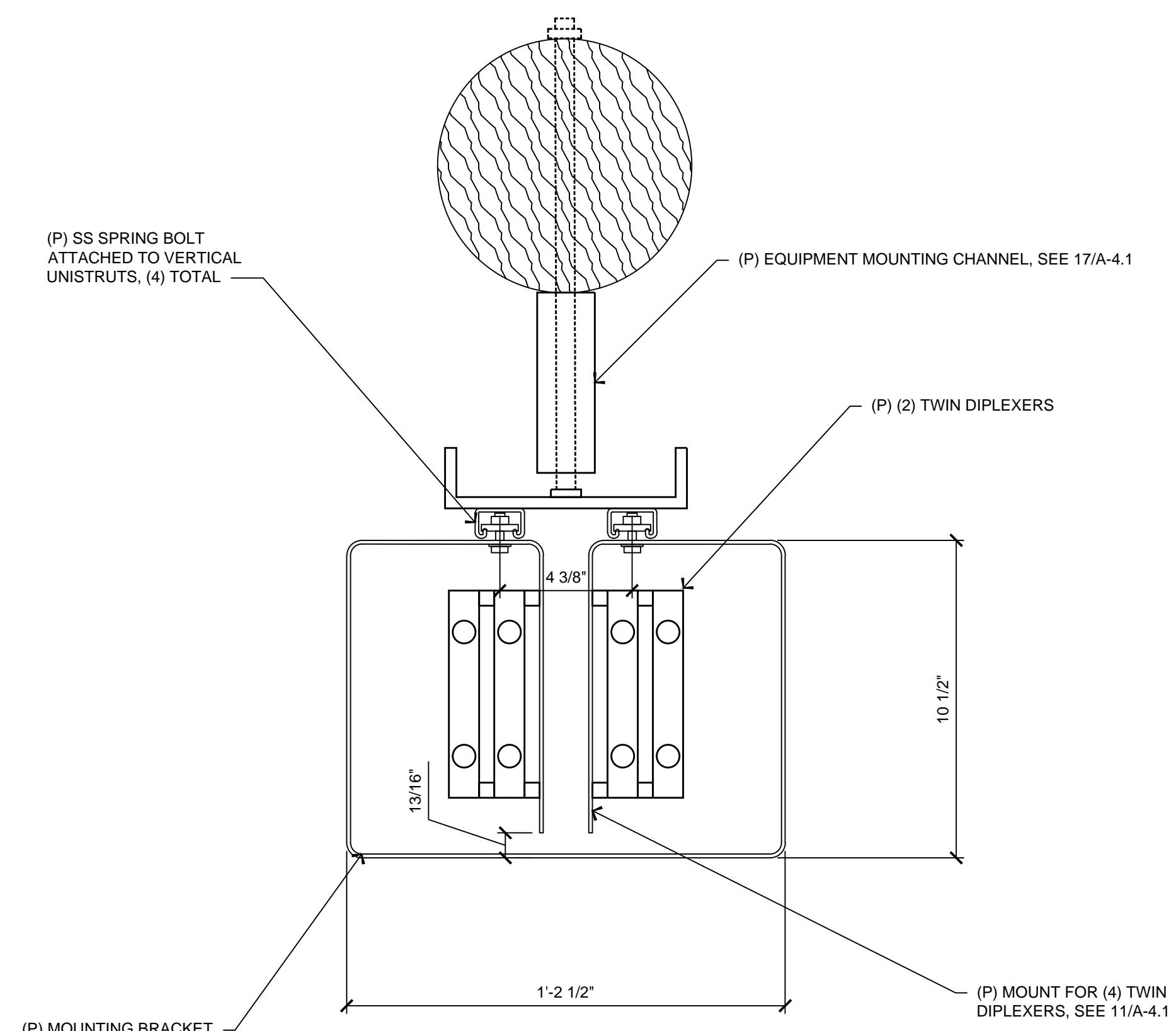
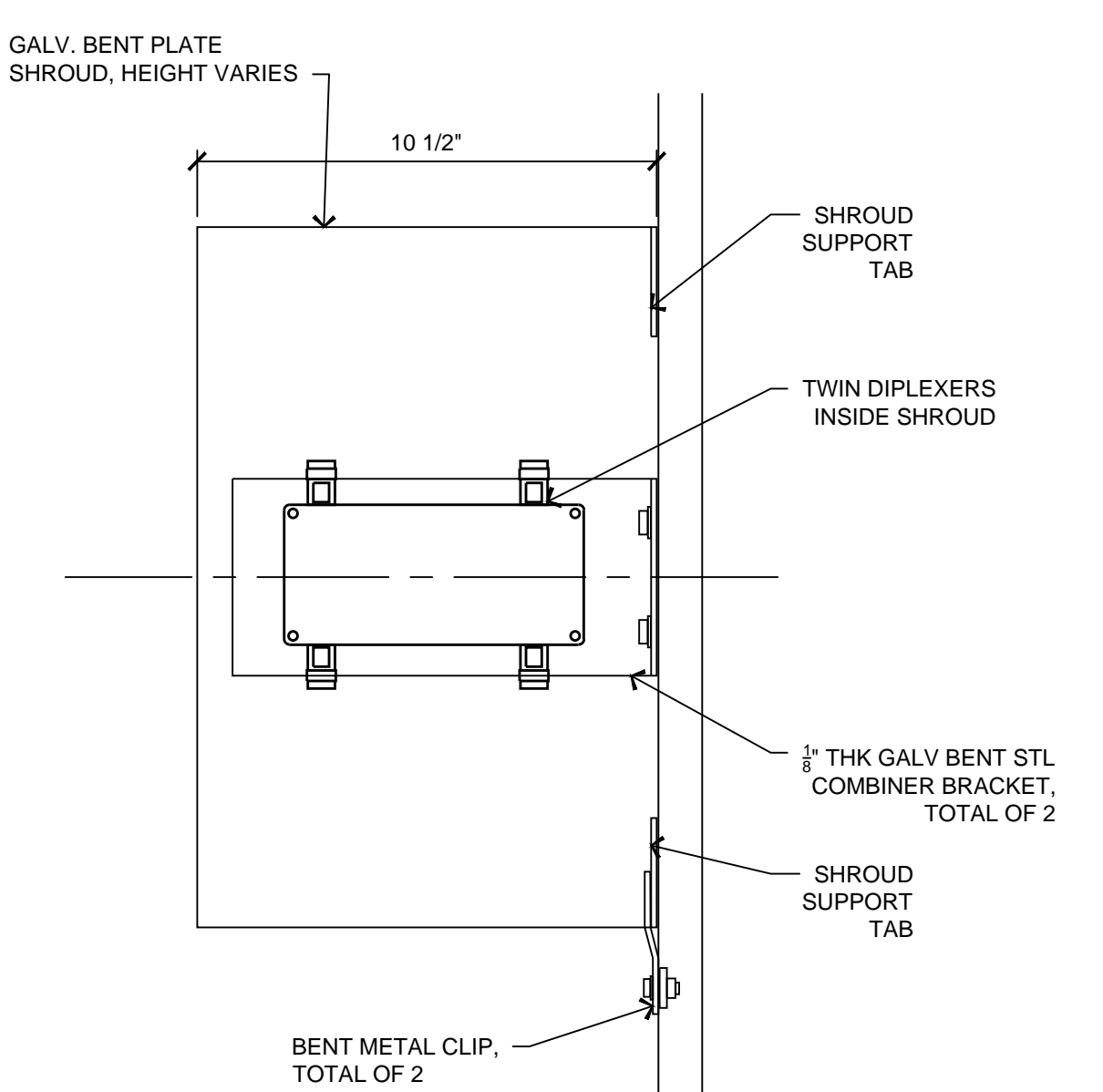
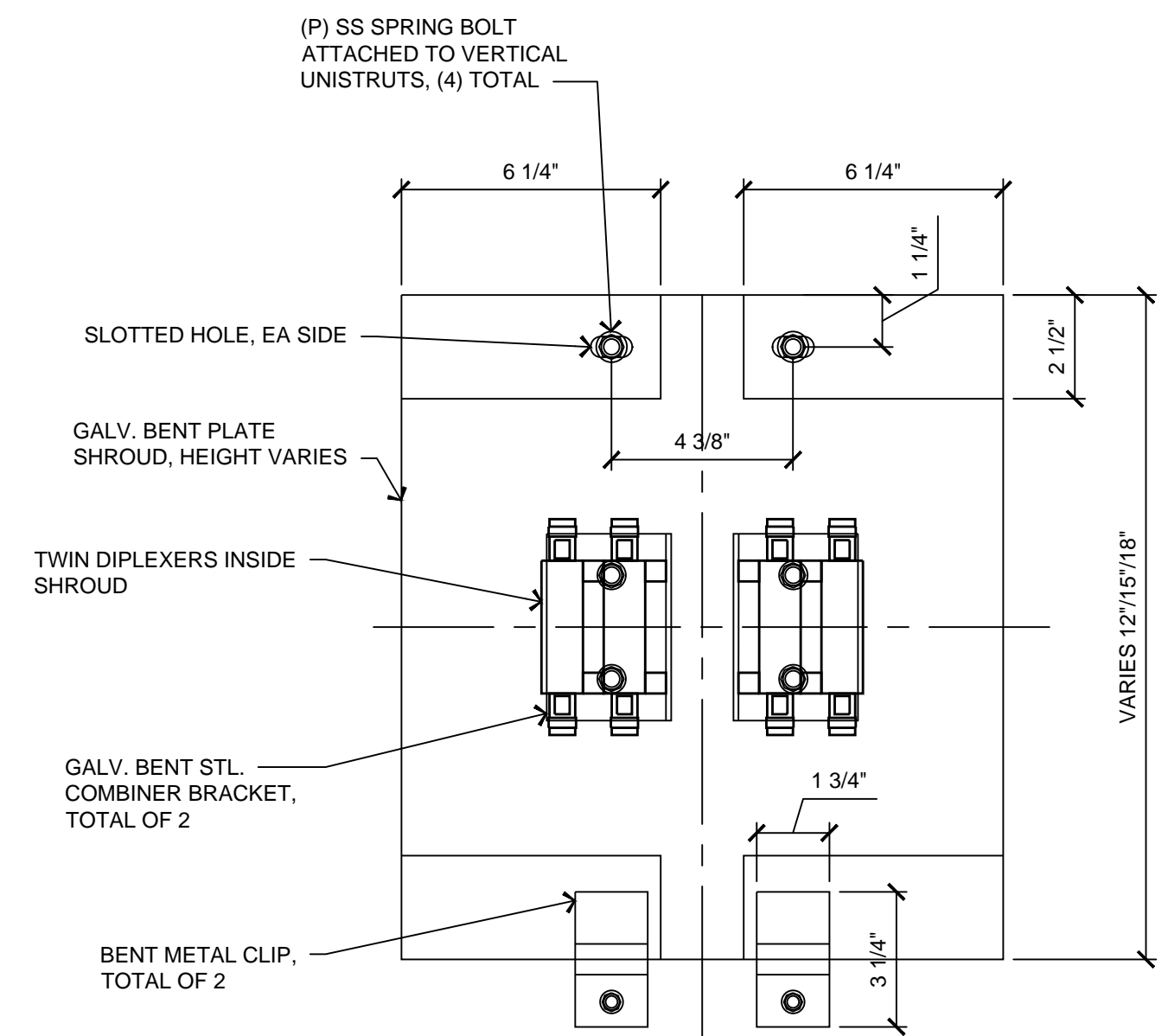

13 COMBINER SHROUD DETAIL  
 3" = 1'-0"



2785 MITCHELL DRIVE, SUITE 9  
 WALNUT CREEK, CA 94598



modus-corp.com

240 STOCKTON STREET, 3RD FLOOR  
 SAN FRANCISCO, CA 94108



borgesarch.com

1478 STONE POINT DRIVE, SUITE 350  
 ROSEVILLE CA 95661  
 916 782 7200 TEL  
 916 773 3037 FAX

REV	DATE	DESCRIPTION
1	02/21/18	90% CD SUBMITTAL
0	10/24/17	90% CD SUBMITTAL

SITE NUMBER:

**BUR\_018**

SITE ADDRESS:  
 138 VALDEFLORES DR  
 BURLINGAME, CA 94010

STAMP

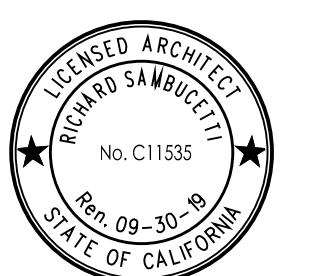

DRAWN BY: D.A.G. PROJECT NO.: T-16519-48

CHECK BY: B.K.W.

SHEET TITLE

DETAILS

SHEET NO.

**A-4.2**



**ELECTRICAL NOTES**

**GENERAL REQUIREMENTS:**

- ALL WORK AND MATERIALS SHALL BE IN ACCORDANCE WITH THE LATEST RULES AND REGULATIONS OF THE NATIONAL ELECTRICAL CODE AND ALL STATE AND LOCAL CODES. NOTHING IN THESE PLANS OR SPECIFICATIONS SHALL BE CONSTRUED AS TO PERMIT WORK NOT CONFORMING TO THE MOST STRINGENT OF THESE CODES. SHOULD CHANGES BE NECESSARY IN THE DRAWINGS OR SPECIFICATIONS TO MAKE THE WORK COMPLY WITH THESE REQUIREMENTS, THE CONTRACTOR SHALL IMMEDIATELY NOTIFY THE ARCHITECT IN WRITING AND CEASE WORK ON PARTS OF THE CONTRACT WHICH ARE AFFECTED.
- THE CONTRACTOR SHALL MAKE A SITE VISIT PRIOR TO BIDDING AND CONSTRUCTION TO VERIFY ALL EXISTING CONDITIONS AND SHALL NOTIFY ARCHITECT IMMEDIATELY UPON DISCOVERY OF ANY DISCREPANCIES. THE CONTRACTOR ASSUMES ALL LIABILITY FOR FAILURE TO COMPLY WITH THIS PROVISION.
- THE EXTENT OF THE WORK IS INDICATED BY THE DRAWINGS, SCHEDULES, AND SPECIFICATIONS AND IS SUBJECT TO THE TERMS AND CONDITIONS OF THE CONTRACT. THE WORK SHALL CONSIST OF FURNISHING ALL LABOR, EQUIPMENT, MATERIALS, AND SUPPLIES NECESSARY FOR A COMPLETE AND OPERATIONAL ELECTRICAL SYSTEM. THE WORK SHALL ALSO INCLUDE THE COMPLETION OF ALL ELECTRICAL WORK NOT MENTIONED OR SHOWN WHICH IS NECESSARY FOR SUCCESSFUL OPERATION OF ALL SYSTEMS.
- THE CONTRACTOR SHALL PREPARE A BID FOR A COMPLETE AND OPERATIONAL SYSTEM, WHICH INCLUDES THE COST FOR MATERIAL AND LABOR.
- WORKMANSHIP AND NEAT APPEARANCE SHALL BE AS IMPORTANT AS THE OPERATION. DEFECTIVE OR DAMAGED MATERIALS SHALL BE REPLACED OR REPAIRED PRIOR TO FINAL ACCEPTANCE IN A MANNER ACCEPTABLE TO OWNER AND ENGINEER.
- COMPLETE THE ENTIRE INSTALLATION AS SOON AS THE PROGRESS OF THE WORK WILL PERMIT. ARRANGE ANY OUTAGE OF SERVICE WITH THE OWNER AND BUILDING MANAGER IN ADVANCE. MINIMIZE DOWNTIME ON THE BUILDING ELECTRICAL SYSTEM.
- THE ENTIRE ELECTRICAL SYSTEM INSTALLED UNDER THIS CONTRACT SHALL BE DELIVERED IN PROPER WORKING ORDER. REPLACE, WITHOUT ADDITIONAL COST TO THE OWNER, ANY DEFECTIVE MATERIAL AND EQUIPMENT WITHIN ONE YEAR FROM THE DATE OF FINAL ACCEPTANCE.
- ANY ERROR, OMISSION OR DESIGN DISCREPANCY ON THE DRAWINGS SHALL BE BROUGHT TO THE ATTENTION OF THE ENGINEER FOR CLARIFICATION OR CORRECTION BEFORE CONSTRUCTION.
- "PROVIDE" INDICATES THAT ALL ITEMS ARE TO BE FURNISHED, INSTALLED AND CONNECTED IN PLACE.
- CONTRACTOR SHALL SECURE ALL NECESSARY BUILDING PERMITS AND PAY ALL REQUIRED FEES.

**EQUIPMENT LOCATION:**

- THE DRAWINGS INDICATE DIAGRAMMATICALLY THE DESIRED LOCATIONS OR ARRANGEMENTS OF CONDUIT RUNS, OUTLETS, EQUIPMENT, ETC., AND ARE TO BE FOLLOWED AS CLOSELY AS POSSIBLE. PROPER JUDGEMENT MUST BE EXERCISED IN EXECUTING THE WORK SO AS TO SECURE THE BEST POSSIBLE INSTALLATION IN THE AVAILABLE SPACE LIMITATIONS OR INTERFERENCE OF STRUCTURE CONDITIONS ENCOUNTERED.
- IN THE EVENT CHANGES IN THE INDICATED LOCATIONS OR ARRANGEMENTS ARE NECESSARY, DUE TO FIELD CONDITIONS IN THE BUILDING CONSTRUCTION OR REARRANGEMENT OF FURNISHINGS OR EQUIPMENT, SUCH CHANGES SHALL BE MADE WITHOUT COST, PROVIDING THE CHANGE IS ORDERED BEFORE THE CONDUIT RUNS, ETC., AND WORK DIRECTLY CONNECTED TO THE SAME IS INSTALLED AND NO EXTRA MATERIALS ARE REQUIRED.
- LIGHTING FIXTURES ARE SHOWN IN THEIR APPROXIMATE LOCATIONS ONLY. COORDINATE THE FIXTURE LOCATION WITH MECHANICAL EQUIPMENT TO AVOID INTERFERENCE.
- COORDINATE THE WORK OF THIS SECTION WITH THAT OF ALL OTHER TRADES, WHERE CONFLICTS OCCUR. CONSULT WITH THE RESPECTIVE CONTRACTOR AND COME TO AGREEMENT AS TO CHANGES NECESSARY. OBTAIN WRITTEN ACCEPTANCE FROM ENGINEER FOR THE PROPOSED CHANGES BEFORE PROCEEDING.

**SHOP DRAWINGS:**

- N/A UNLESS NOTED OTHERWISE.

**SUBSTITUTIONS:**

- NO SUBSTITUTIONS ARE ALLOWED

**TESTS:**

- BEFORE FINAL ACCEPTANCE OF WORK, THE CONTRACTOR SHALL INSURE THAT ALL EQUIPMENT, SYSTEMS, FIXTURES, ETC., ARE WORKING SATISFACTORILY AND TO THE INTENT OF THE DRAWINGS.

**PERMITS:**

- THE CONTRACTOR SHALL BE RESPONSIBLE FOR TAKING OUT AND PAYING FOR ALL REQUIRED PERMITS, INSPECTION AND EXAMINATION WITHOUT ADDITIONAL EXPENSE TO THE OWNER.

**GROUNDING:**

- THE CONTRACTOR SHALL PROVIDE A COMPLETE, AND APPROVED GROUNDING SYSTEM INCLUDING ELECTRODES, ELECTRODE CONDUCTOR, BONDING CONDUCTORS, AND EQUIPMENT CONDUCTORS AS REQUIRED BY ARTICLE 250 OF THE NATIONAL ELECTRICAL CODE.
- CONDUITS CONNECTED TO EQUIPMENT AND DEVICES SHALL BE METALICALLY JOINED TOGETHER TO PROVIDE EFFECTIVE ELECTRICAL CONTINUITY.
- FEEDERS AND BRANCH CIRCUIT WIRING INSTALLED IN A NONMETALLIC CONDUIT SHALL INCLUDE A CODE SIZED GROUNDING CONDUCTOR HAVING GREEN INSULATION. THE GROUND CONDUCTOR SHALL BE PROPERLY CONNECTED AT BOTH ENDS TO MAINTAIN ELECTRICAL CONTINUITY.
- REFER TO GROUND BUS DETAILS. PROVIDE NEW GROUND SYSTEM COMPLETE WITH CONDUCTORS, GROUND ROD AND DESCRIBED TERMINATIONS.
- ALL GROUNDING CONDUCTORS SHALL BE SOLID TINNED COPPER AND ANNEALED #2 UNLESS NOTED OTHERWISE.
- ALL NON-DIRECT BURIED TELEPHONE EQUIPMENT GROUND CONDUCTORS SHALL BE #2 STRANDED THHN (GREEN) INSULATION.
- ALL GROUND CONNECTIONS SHALL BE MADE WITH "HYGROUND" COMPRESSION SYSTEM BURNDY CONNECTORS EXCEPT WHERE NOTED OTHERWISE.
- PAIN AT ALL GROUND CONNECTIONS SHALL BE REMOVED.
- GROUNDING SYSTEM RESISTANCE SHALL NOT EXCEED 5 OHMS. IF THE RESISTANCE VALUE IS EXCEEDED, NOTIFY THE OWNER FOR FUTURE INSTRUCTION ON METHODS FOR REDUCING THE RESISTANCE VALUE. SUBMIT TEST REPORTS AND FURNISH TO SMART SMR ONE COMPLETE SET OF PRINTS SHOWING "INSTALLED WORK".

**UTILITY SERVICE:**

- TELEPHONE AND ELECTRICAL METERING FACILITIES SHALL CONFORM TO THE REQUIREMENTS OF THE SERVING UTILITY COMPANIES. CONTRACTOR SHALL VERIFY SERVICE LOCATIONS AND REQUIREMENTS. SERVICE INFORMATION WILL BE FURNISHED BY THE SERVING UTILITIES.
- CONFORM TO ALL REQUIREMENTS OF THE SERVING UTILITY COMPANIES.

**PRODUCTS:**

- ALL MATERIALS SHALL BE NEW, CONFORMING WITH NEC, ANSI, NEMA, AND THEY SHALL BE U.L. LISTED AND LABELED.
- CONDUIT:
  - RIGID CONDUIT SHALL BE U.L. LABEL GALVANIZED ZINC COATED WITH ZINC INTERIOR AND SHALL BE USED WHEN INSTALLED IN OR UNDER CONCRETE SLABS, IN CONTACT WITH THE EARTH, UNDER PUBLIC ROADWAYS, IN MASONRY WALLS OR EXPOSED ON BUILDING EXTERIOR. RIGID CONDUIT IN CONTACT WITH EARTH SHALL BE 1/2 LAPPED WRAPPED WITH HUNTS WRAP PROCESS NO. 3.
  - ELECTRICAL METALLIC TUBING SHALL U.L. LABEL. FITTINGS SHALL BE COMPRESSION TYPE. EMT SHALL BE USED ONLY FOR INTERIOR RUNS.
  - FLEXIBLE METALLIC CONDUIT SHALL HAVE U.L. LISTED LABEL AND MAY BE USED WHERE PERMITTED BY CODE. FITTINGS SHALL BE "JAKE" OR "SQUEEZE" TYPE. SEAL TIGHT FLEXIBLE CONDUIT. ALL CONDUIT EXCESS OF SIX FEET IN LENGTH SHALL HAVE FULL SIZE GROUND WIRE.
  - CONDUIT RUNS MAY BE SURFACE MOUNTED IN CEILING OR WALLS UNLESS INDICATED OTHERWISE. CONDUIT INDICATED SHALL RUN PARALLEL OR AT RIGHT ANGLES TO CEILING, FLOOR OR BEAMS. VERIFY EXACT ROUTING OF ALL EXPOSED CONDUIT WITH ARCHITECT PRIOR TO INSTALLING.
  - ALL UNDERGROUND CONDUITS SHALL BE PVC SCHEDULE 40 (UNLESS NOTED OTHERWISE) AT A MINIMUM DEPTH OF 24" BELOW GRADE
  - ALL CONDUIT ONLY (C.O.) SHALL HAVE PULL ROPE.
  - CONDUITS RUN ON ROOFS SHALL BE INSTALLED ON 4x4 REDWOOD SLEEPERS, 6'-0" ON CENTER, SET IN NON-HARDENING MASTIC.
- ALL WIRE AND CABLE SHALL BE COPPER, 600 VOLT, #12 AWG MINIMUM UNLESS SPECIFICALLY NOTED OTHERWISE ON THE DRAWINGS. CONDUCTORS #10 AWG AND SMALLER SHALL BE SOLID. CONDUCTORS #8 AWG AND LARGER SHALL BE STRANDED. TYPE THHN INSULATION USED UNLESS CONDUCTORS INSTALLED IN CONDUIT EXPOSED TO WEATHER, IN WHICH CASE TYPE THWN INSULATION SHALL BE USED.
- PROVIDE GALVANIZED COATED STEEL BOXES AND ACCESSORIES SIZED PER CODE TO ACCOMMODATE ALL DEVICES AND WIRING.
- DUPLEX RECEPTACLES SHALL BE SPECIFICATION GRADE WITH WHITE FINISH (UNLESS NOTED BY ENGINEER), 20 AMP, 125 VOLT, THREE WIRE GROUNDING TYPE, NEMA 5-20R. MOUNT RECEPTACLE AT +12" ABOVE FINISHED FLOOR UNLESS OTHERWISE INDICATED ON DRAWINGS OR IN DETAILS. WEATHERPROOF RECEPTACLES SHALL BE GROUND FAULT INTERRUPTER TYPE WITH SIERRA #WPD-8 LIFT COVERPLATES.
- TOGGLE SWITCHES SHALL BE 20 AMP, 120 VOLT AC, SPECIFICATION GRADE WHITE (UNLESS NOTED OTHERWISE) FINISH. MOUNT SWITCHES AT +48" ABOVE FINISHED FLOOR.
- PANELBOARDS SHALL BE DEAD FRONT SAFETY TYPE WITH ANTI-BURN SOLDERLESS COMPRESSION APPROVED FOR COPPER CONDUCTORS, COPPER BUS BARS, FULL SIZED NEUTRAL BUS, GROUND BUS AND EQUIPPED WITH QUICK-MAKE QUICK-BREAK BOLT-IN TYPE THERMAL MAGNETIC CIRCUIT BREAKERS. MOUNT TOP OF THE PANELBOARDS AT 6'-3" ABOVE FINISHED FLOOR. PROVIDE TYPE WRITTEN CIRCUIT DIRECTORY.
- ALL CIRCUIT BREAKERS, MAGNETIC STARTERS AND OTHER ELECTRICAL EQUIPMENT SHALL HAVE AN INTERRUPTING RATING NOT LESS THAN MAXIMUM SHORT CIRCUIT CURRENT TO WHICH THEY MAY BE SUBJECTED.
- GROUND RODS SHALL BE COPPER CLAD STEEL, 5/8" ROUND AND 10' LONG. COPPERWELD OR APPROVED EQUAL.

**INSTALLATION:**

- PROVIDE SUPPORTING DEVICES FOR ALL ELECTRICAL EQUIPMENT, FIXTURES, BOXES, PANEL, ETC., SUPPORT LUMINARIES FROM UNDERSIDE OF STRUCTURAL CEILING. EQUIPMENT SHALL BE BRACED TO WITHSTAND HORIZONTAL FORCES IN ACCORDANCE WITH STATE AND LOCAL CODE REQUIREMENTS. PROVIDE PRIOR ALIGNMENT AND LEVELING OF ALL DEVICES AND FIXTURES.
- CUTTING, PATCHING, CHASES, OPENINGS: PROVIDE LAYOUT IN ADVANCE TO ELIMINATE UNNECESSARY CUTTING OR DRILLING OF WALLS, FLOORS CEILINGS, AND ROOFS. ANY DAMAGE TO BUILDING STRUCTURE OR EQUIPMENT SHALL BE REPAIRED BY THE CONTRACTOR. OBTAIN PERMISSION FROM THE ENGINEER BEFORE CORING.
- IN DRILLING HOLES INTO CONCRETE WHETHER FOR FASTENING OR ANCHORING PURPOSES, OR PENETRATIONS THROUGH THE FLOOR FOR CONDUIT RUNS, PIPE RUNS, ETC., IT MUST BE CLEARLY UNDERSTOOD THAT TENDONS AND/OR REINFORCING STEEL WILL NOT BE DRILLED INTO, CUT OR DAMAGED UNDER THE CIRCUMSTANCES.
- LOCATION OF TENDONS AND/OR REINFORCING STEEL ARE NOT DEFINITELY KNOWN AND THEREFORE, MUST BE SEARCHED FOR BY APPROPRIATE METHODS AND EQUIPMENT VIA X-RAY OR OTHER DEVICES THAT CAN ACCURATELY LOCATE THE REINFORCING AND/OR STEEL TENDONS.
- PENETRATIONS IN FIRE RATED WALLS SHALL BE FIRE STOPPED IN ACCORDANCE WITH THE REQUIREMENTS OF THE C.B.C.

**PROJECT CLOSEOUT:**

- UPON COMPLETION OF WORK, CONDUCT CONTINUITY, SHORT CIRCUIT, AND FALL POTENTIAL GROUNDING TESTS FOR APPROVAL. SUBMIT TEST REPORTS TO PROJECT MANAGER. CLEAN PREMISES OF ALL DEBRIS RESULTING FROM WORK AND LEAVE WORK IN A COMPLETE AND UNDAMAGED CONDITION.
- PROVIDE PROJECT MANAGER WITH ONE SET OF COMPLETE ELECTRICAL "AS INSTALLED" DRAWINGS AT THE COMPLETION OF THE JOB, SHOWING ACTUAL DIMENSIONS, ROUTINGS AND CIRCUITS.
- ALL BROCHURES, OPERATING MANUALS, CATALOG, SHOP DRAWINGS, ETC., SHALL BE TURNED OVER TO OWNER AT JOB COMPLETION.

**GROUNDING NOTES:**

- ALL DETAILS ARE SHOWN IN GENERAL TERMS. ACTUAL GROUNDING INSTALLATION REQUIREMENTS AND CONSTRUCTION ACCORDING TO SITE CONDITIONS.
- ALL GROUNDING CONDUCTORS: #2 AWG SOLID BARE TINNED COPPER WIRE UNLESS OTHERWISE NOTED.
- GROUND BAR LOCATED IN BASE OF EQUIPMENT WILL BE PROVIDED, FURNISHED AND INSTALLED BY THE VENDOR.
- ALL BELOW GRADE CONNECTIONS: EXOTHERMIC WELD TYPE, ABOVE GRADE CONNECTIONS: EXOTHERMIC WELD TYPE.
- GROUND RING SHALL BE LOCATED A MINIMUM OF 24" BELOW GRADE OR 6" MINIMUM BELOW THE FROST LINE.
- INSTALL GROUND CONDUCTORS AND GROUND ROD MINIMUM OF 1'-0" FROM EQUIPMENT CONCRETE SLAB, SPREAD FOOTING, OR FENCE.
- EXOTHERMIC WELD GROUND CONNECTION TO FENCE POST: TREAT WITH A COLD GALVANIZED SPRAY.
- GROUND BARS:
  - EQUIPMENT GROUND BUS BAR (EGB) LOCATED AT THE BOTTOM OF ANTENNA POLE/MAST FOR MAKING GROUNDING JUMPER CONNECTIONS TO COAX FEEDER CABLES SHALL BE FURNISHED AND INSTALLED BY ELECTRICAL CONTRACTOR. JUMPERS (FURNISHED BY OWNERS) SHALL BE INSTALLED AND CONNECTED BY ELECTRICAL CONTRACTOR.
- ALL GROUNDING INSTALLATIONS AND CONNECTIONS SHALL BE MADE BY ELECTRICAL CONTRACTOR.
- OBSERVE N.E.C. AND LOCAL UTILITY REQUIREMENTS FOR ELECTRICAL SERVICE GROUNDING.
- GROUNDING ATTACHMENT TO TOWER SHALL BE AS PER MANUFACTURER'S RECOMMENDATIONS OR AT GROUNDING POINTS PROVIDED (2 MINIMUM).
- IF EQUIPMENT IS IN A C.L. FENCE ENCLOSURE, GROUND ONLY CORNER POSTS AND SUPPORT POSTS OF GATE. IF CHAIN LINK LID IS USED, THEN GROUND LID ALSO.
- GROUNDING AT PPC CABINET SHALL BE VERTICALLY INSTALLED.
- ALL GROUNDING FOR ANTENNAS SHALL BE CONNECTED SO THAT IT WILL BY-PASS MAIN BUSS BAR.
- ALL EMT RUNS SHALL BE GROUNDED AND HAVE A BUSHING, NO PVC ABOVE GROUND.
- USE SEPARATE HOLES FOR GROUNDING AT BUSS BAR. NO "DOUBLE-UP" OF IUGS.
- POWER AND TELCO CABINETS SHALL BE GROUNDED (BONDED) TOGETHER.
- NO LBS ALLOWED ON GROUNDING.
- PROVIDE STAINLESS STEEL CLAMP AND BRASS TAGS ON COAX AT ANTENNAS AND DOGHOUSE.

NOTE:  
NEW VINYL SIGN TO BE PROVIDED BY VERICON WIRELESS AND BE LOCATED ON THE SIDE OF THE METER BOX. SIGN TO BE YELLOW.

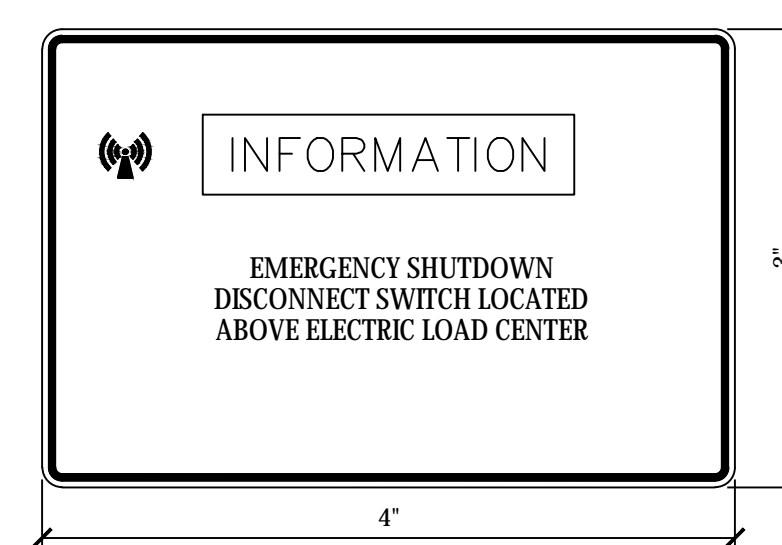

**4 SHUTDOWN DISCONNECT SIGNAGE**  
NOT TO SCALE

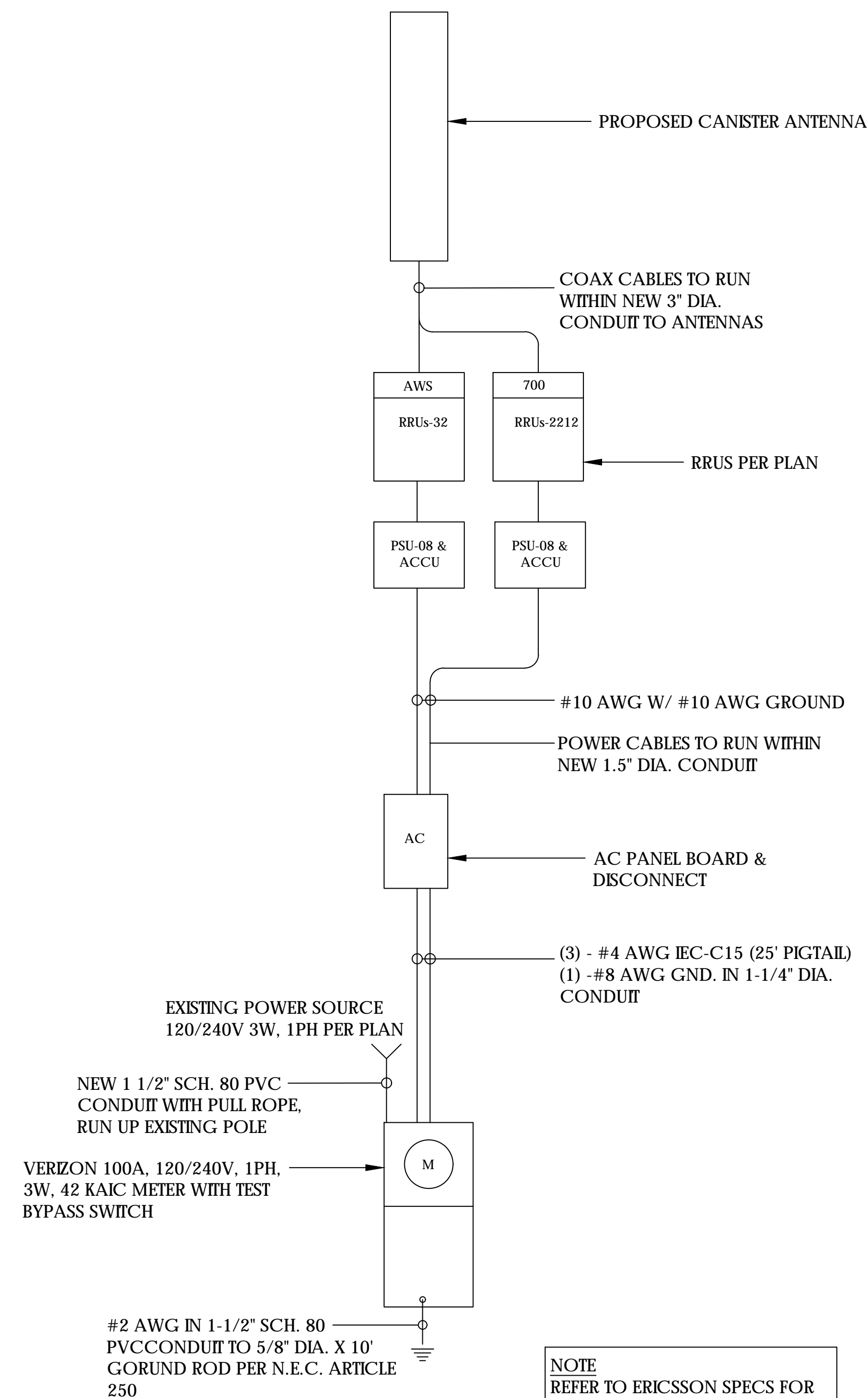

NOTE  
REFER TO ERICSSON SPECS FOR ADDITIONAL INFORMATION INCLUDING WIRING INSTRUCTIONS & GROUNDING REQUIREMENTS

**5 ELECTRICAL NOTES**  
N.I.S.



2785 MITCHELL DRIVE, SUITE 9  
WALNUT CREEK, CA 94598



modus-corp.com

240 STOCKTON STREET, 3RD FLOOR  
SAN FRANCISCO, CA 94108



borgesarch.com

1478 STONE POINT DRIVE, SUITE 350  
ROSEVILLE CA 95661

916 782 7200 TEL

916 773 3037 FAX

REV	DATE	DESCRIPTION
1	02/21/18	90% CD SUBMITTAL
0	10/24/17	90% CD SUBMITTAL

**SITE NUMBER:**

**BUR\_018**

**SITE ADDRESS:**  
138 VALDEFLORES DR  
BURLINGAME, CA 94010

STAMP

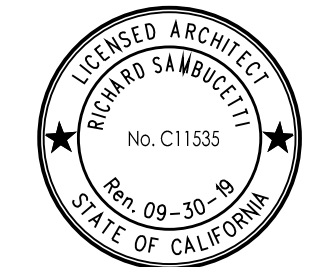

DRAWN BY: D.A.G. PROJECT NO.: T-16519-48

CHECK BY: B.K.W.

**SHEET TITLE**  
SINGLE LINE  
DIAGRAM & PANEL  
SCHEDULE

SHEET NO.



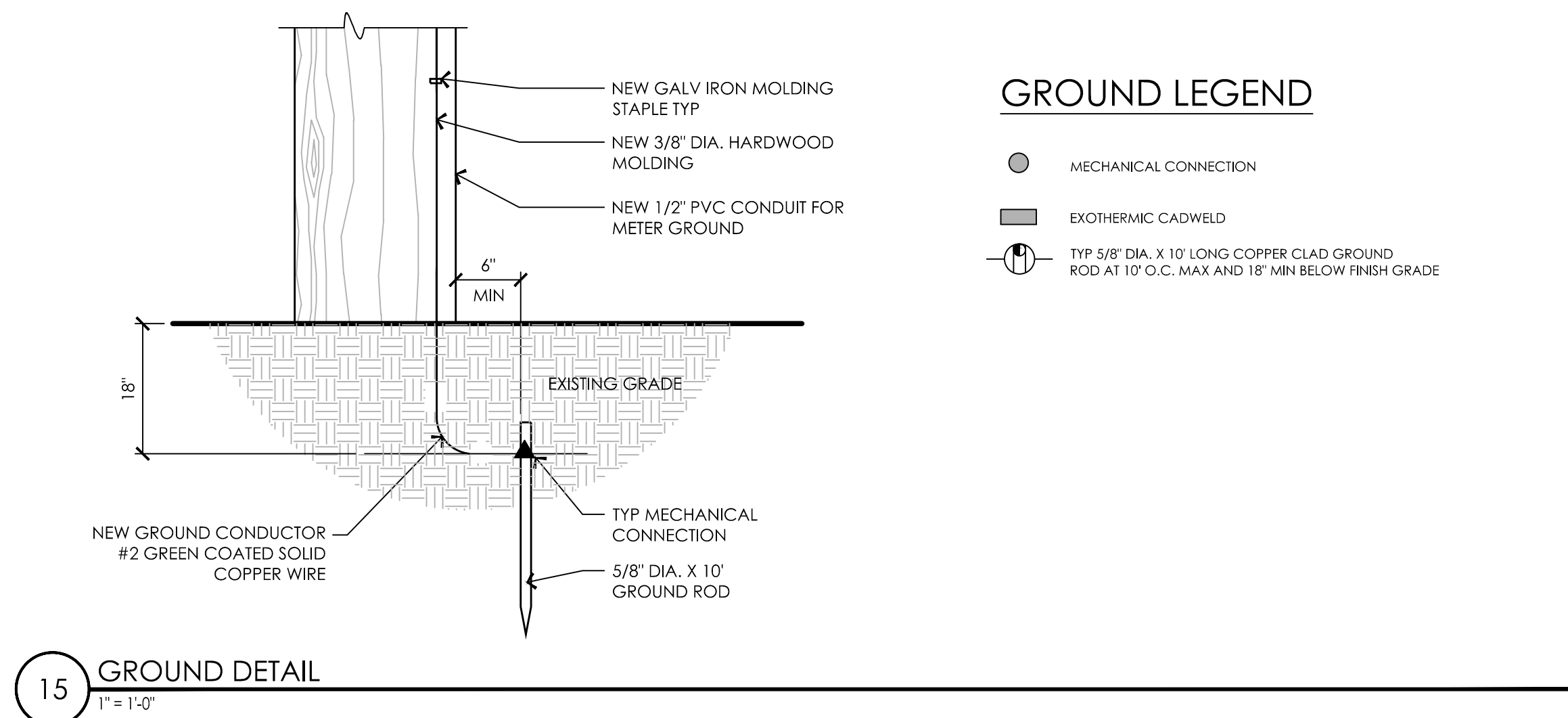

**5** GROUNDING PLAN  
1/2" = 1'-0"

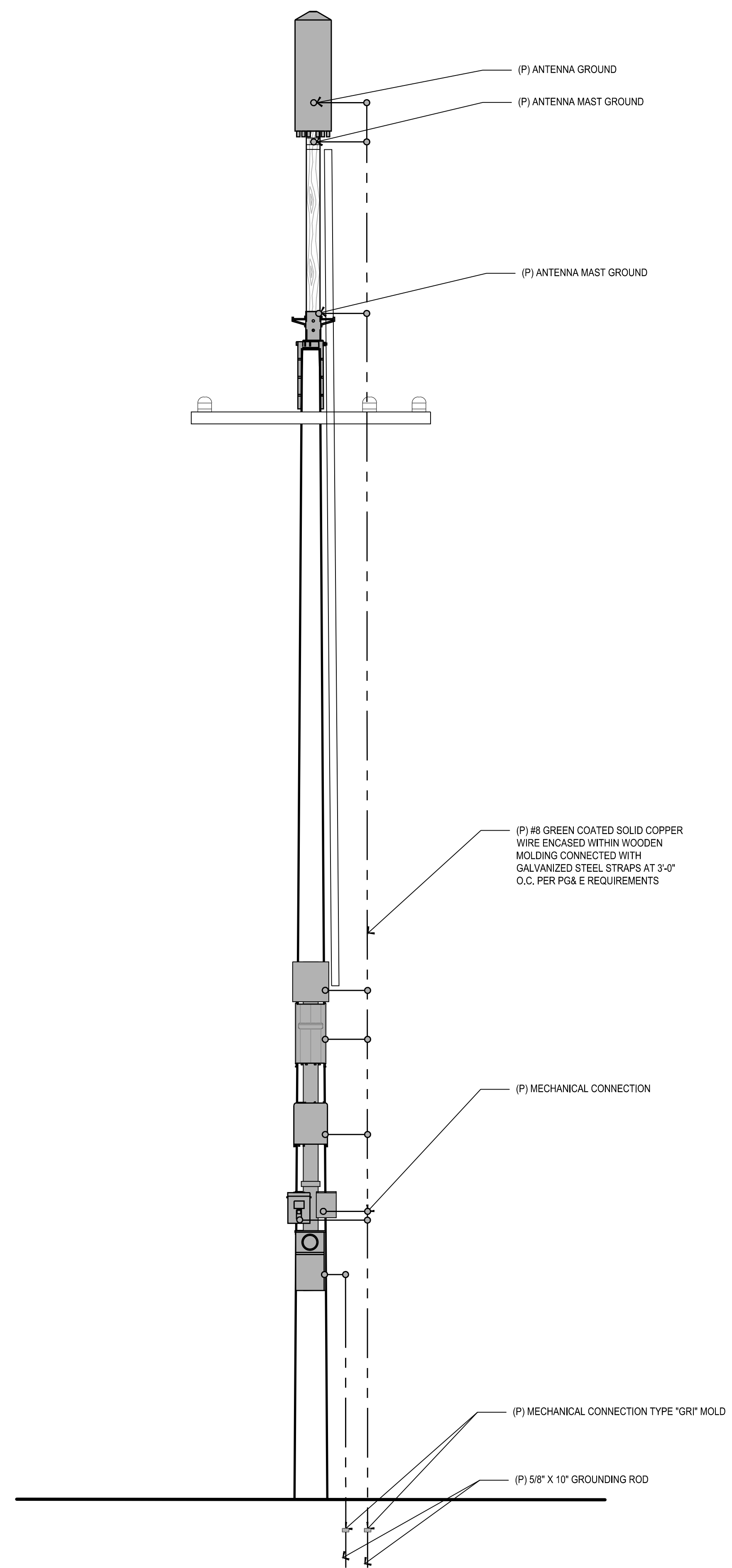

REV	DATE	DESCRIPTION
1	02/21/18	90% CD SUBMITTAL
0	10/24/17	90% CD SUBMITTAL

**SITE NUMBER:**

**BUR\_018**

**SITE ADDRESS:**  
138 VALDEFLORES DR  
BURLINGAME, CA 94010

STAMP

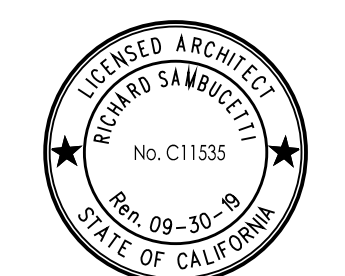

DRAWN BY: D.A.G. PROJECT NO.: T-16519-48  
CHECK BY: B.K.W.

**SHEET TITLE**  
POLE GROUND &  
RISER DIAGRAM &  
DETAILS

SHEET NO.



**County of San Mateo - Planning and Building Department**

# **ATTACHMENT D-2**

*Existing*



*Proposed*



Proposed Verizon  
Antenna & Equipment

view from Valdeflores Drive looking northwest at site  
SF Burlingame 018  
138 Valdeflores Drive, Burlingame, CA  
Photosims Produced on 2-23-2018

*Existing*



*Proposed*



Proposed Verizon  
Antenna & Equipment

*view from Hillside Drive looking east at site*  
SF Burlingame 019  
Adjacent to 2866 Hillside Drive, Burlingame, CA  
Photosims Produced on 2-14-2018



**County of San Mateo - Planning and Building Department**

# **ATTACHMENT D-3**



PG&E Wood Utility Pole:  
Pole is viable but potentially  
too far from area desired  
coverage area

PG&E Wood Utility Pole:  
Pole is potentially viable and  
would need some tree  
abatement

SITE SELECTED

PG&E Wood Utility Pole: Pole  
is viable

PG&E Wood Utility Pole: Too  
busy, the pole does not have  
open quadrants for  
equipment and installation

PG&E Wood Utility Pole: pole  
is viable but too far from area  
RF wishes to cover



**County of San Mateo - Planning and Building Department**

# **ATTACHMENT D-4**



# Radio Frequency - Electromagnetic Energy (RF-EME) Jurisdictional Report

Site No. 438510  
SF BURLINGAME 019  
2866 Hillside Dr  
Burlingame, California 94010  
San Mateo County  
37° 34' 48.09" N, -122° 23' 9.69" W NAD83

EBI Project No. 6218000383  
February 4, 2018



Prepared for:  
Verizon Wireless  
c/o Modus, Inc.  
115 Sansome Street, 14<sup>th</sup> floor  
San Francisco, CA 94104

Prepared by:  
 **EBI Consulting**  
environmental | engineering | due diligence

## TABLE OF CONTENTS

<b>EXECUTIVE SUMMARY.....</b>	<b>2</b>
<b>1.0 INTRODUCTION .....</b>	<b>3</b>
<b>2.0 SITE DESCRIPTION .....</b>	<b>3</b>
<b>3.0 FEDERAL COMMUNICATIONS COMMISSION (FCC) REQUIREMENTS .....</b>	<b>3</b>
<b>4.0 WORST-CASE PREDICTIVE MODELING.....</b>	<b>6</b>
<b>5.0 MITIGATION/SITE CONTROL OPTIONS .....</b>	<b>7</b>
<b>6.0 SUMMARY AND CONCLUSIONS.....</b>	<b>7</b>
<b>7.0 LIMITATIONS .....</b>	<b>7</b>

## APPENDICES

<b>APPENDIX A CERTIFICATIONS</b>	
<b>APPENDIX B RADIO FREQUENCY ELECTROMAGNETIC ENERGY SAFETY / SIGNAGE PLANS</b>	
<b>APPENDIX C ROOFVIEW® EXPORT FILES</b>	

## EXECUTIVE SUMMARY

### Purpose of Report

EnviroBusiness Inc. (dba EBI Consulting) has been contracted by Verizon Wireless to conduct radio frequency electromagnetic (RF-EME) modeling for Verizon Site 438510 located at 1021 Lane St in Belmont, California to determine RF-EME exposure levels from proposed Verizon wireless communications equipment at this site. As described in greater detail in Section 2.0 of this report, the Federal Communications Commission (FCC) has developed Maximum Permissible Exposure (MPE) Limits for general public exposures and occupational exposures. This report summarizes the results of RF-EME modeling in relation to relevant FCC RF-EME compliance standards for limiting human exposure to RF-EME fields.

### Statement of Compliance

A site is considered out of compliance with FCC regulations if there are areas that exceed the FCC exposure limits and there are no RF hazard mitigation measures in place. Any carrier which has an installation that contributes more than 5% of the applicable MPE must participate in mitigating these RF hazards.

As presented in the sections below, based on worst-case predictive modeling, there are no modeled areas on any accessible ground-level walking/working surface related to the proposed antennas that exceed the FCC's occupational or general public exposure limits at this site.

At the nearest walking/working surfaces to the Verizon antennas, the maximum power density generated by the Verizon antennas is approximately **7.20** percent of the FCC's general public limit (**1.44** percent of the FCC's occupational limit).

The composite exposure level from all carriers on this site is approximately **7.20** percent of the FCC's general public limit (**1.44** percent of the FCC's occupational limit) at the nearest walking/working surface to each antenna.

Recommended control measures are outlined in Section 5.0 and within a Site Safety Plan (attached); this plan includes instructions to shut down and lockout/tagout this wireless equipment in accordance with Verizon's standard operating protocol.

## 1.0 INTRODUCTION

Radio frequency waves are electromagnetic waves from the portion of the electromagnetic spectrum at frequencies lower than visible light and microwaves. The wavelengths of radio waves range from thousands of meters to around 30 centimeters. These wavelengths correspond to frequencies as low as 3 cycles per seconds (or hertz [Hz]) to as high as one gigahertz (one billion cycles per second).

Personal Communication (PCS) facilities used by Verizon in this area operate within a frequency range of 1900-2100 MHz. Facilities typically consist of: 1) electronic transceivers (the radios or cabinets) connected to wired telephone lines; and 2) antennas that send the wireless signals created by the transceivers to be received by individual subscriber units (PCS telephones). Transceivers are typically connected to antennas by coaxial cables.

Because of the short wavelength of PCS services, the antennas require line-of-site paths for good propagation, and are typically installed a distance above ground level. Antennas are constructed to concentrate energy towards the horizon, with as little energy as possible scattered towards the ground or the sky. This design, combined with the low power of PCS facilities, generally results in no possibility for exposure to approach Maximum Permissible Exposure (MPE) levels, with the exception of in areas in the immediate vicinity of the antennas.

MPE limits do not represent levels where a health risk exists, since they are designed to provide a substantial margin of safety. These limits apply for continuous exposures and are intended to provide a prudent margin of safety for all persons, regardless of age, gender, size or health.

## 2.0 SITE DESCRIPTION

This project site includes one (1) wireless telecommunication antenna (at two transmitting sectors) on a utility pole located at 1021 Lane St in Belmont, California.

Verizon Antenna Information (proposed Configuration)									
Antenna # and Model	Frequency (MHz)	# of Transmitters	Transmit Power (Watts)	Azimuth	Gain (dBd)	Feet above Ground (CL)	X	Y	Z (feet)
A1 Amphenol CUUT070X12Fxyz0	1900	2	60	110°	6.85	47.92	30	30	45.92
	2100	2	60	230°	9.85				

The FCC guidelines incorporate two separate tiers of exposure limits that are based upon occupational/controlled exposure limits (for workers) and general population/uncontrolled exposure limits for members of the general public that may be exposed to antenna fields. While access to this site is considered uncontrolled, the analysis has considered exposures with respect to both controlled and uncontrolled limits as an untrained worker may access adjacent rooftop locations. Additional information regarding controlled/uncontrolled exposure limits is provided in Section 3.0. Appendix B presents a site safety plan that provides a plan view of the utility pole with antenna locations.

## 3.0 FEDERAL COMMUNICATIONS COMMISSION (FCC) REQUIREMENTS

The FCC has established Maximum Permissible Exposure (MPE) limits for human exposure to Radiofrequency Electromagnetic (RF-EME) energy fields, based on exposure limits recommended by the

National Council on Radiation Protection and Measurements (NCRP) and, over a wide range of frequencies, the exposure limits developed by the Institute of Electrical and Electronics Engineers, Inc. (IEEE) and adopted by the American National Standards Institute (ANSI) to replace the 1982 ANSI guidelines. Limits for localized absorption are based on recommendations of both ANSI/IEEE and NCRP.

The FCC guidelines incorporate two separate tiers of exposure limits that are based upon occupational/controlled exposure limits (for workers) and general public/uncontrolled exposure limits for members of the general public.

**Occupational/controlled exposure limits** apply to situations in which persons are exposed as a consequence of their employment and in which those persons who are exposed have been made fully aware of the potential for exposure and can exercise control over their exposure. Occupational/controlled exposure limits also apply where exposure is of a transient nature as a result of incidental passage through a location where exposure levels may be above general public/uncontrolled limits (see below), as long as the exposed person has been made fully aware of the potential for exposure and can exercise control over his or her exposure by leaving the area or by some other appropriate means.

**General public/uncontrolled exposure limits** apply to situations in which the general public may be exposed or in which persons who are exposed as a consequence of their employment may not be made fully aware of the potential for exposure or cannot exercise control over their exposure. Therefore, members of the general public would always be considered under this category when exposure is not employment-related, for example, in the case of a telecommunications tower that exposes persons in a nearby residential area.

Table I and Figure I (below), which are included within the FCC’s OET Bulletin 65, summarize the MPE limits for RF emissions. These limits are designed to provide a substantial margin of safety. They vary by frequency to take into account the different types of equipment that may be in operation at a particular facility and are “time-averaged” limits to reflect different durations resulting from controlled and uncontrolled exposures.

The FCC’s MPEs are measured in terms of power (mW) over a unit surface area (cm<sup>2</sup>). Known as the power density, the FCC has established an occupational MPE of 5 milliwatts per square centimeter (mW/cm<sup>2</sup>) and an uncontrolled MPE of 1 mW/cm<sup>2</sup> for equipment operating in the 1900 MHz frequency range. For the Verizon equipment operating at 700 MHz or 850 MHz, the FCC’s occupational MPE is 2.83 mW/cm<sup>2</sup> and an uncontrolled MPE of 0.57 mW/cm<sup>2</sup>. These limits are considered protective of these populations.

<b>Table I: Limits for Maximum Permissible Exposure (MPE)</b>				
<b>(A) Limits for Occupational/Controlled Exposure</b>				
<b>Frequency Range (MHz)</b>	<b>Electric Field Strength (E) (V/m)</b>	<b>Magnetic Field Strength (H) (A/m)</b>	<b>Power Density (S) (mW/cm<sup>2</sup>)</b>	<b>Averaging Time [E]<sup>2</sup>, [H]<sup>2</sup>, or S (minutes)</b>
0.3-3.0	614	1.63	(100)*	6
3.0-30	1842/f	4.89/f	(900/f <sup>2</sup> )*	6
30-300	61.4	0.163	1.0	6
300-1,500	--	--	f/300	6
1,500-100,000	--	--	5	6
<b>(B) Limits for General Public/Uncontrolled Exposure</b>				

Frequency Range (MHz)	Electric Field Strength (E) (V/m)	Magnetic Field Strength (H) (A/m)	Power Density (S) (mW/cm <sup>2</sup> )	Averaging Time [E] <sup>2</sup> , [H] <sup>2</sup> , or S (minutes)
0.3-1.34	614	1.63	(100)*	30
1.34-30	824/f	2.19/f	(180/f <sup>2</sup> )*	30
30-300	27.5	0.073	0.2	30
300-1,500	--	--	f/1,500	30
1,500-100,000	--	--	1.0	30

f = Frequency in (MHz)

\* Plane-wave equivalent power density

Figure 1. FCC Limits for Maximum Permissible Exposure (MPE)  
 Plane-wave Equivalent Power Density

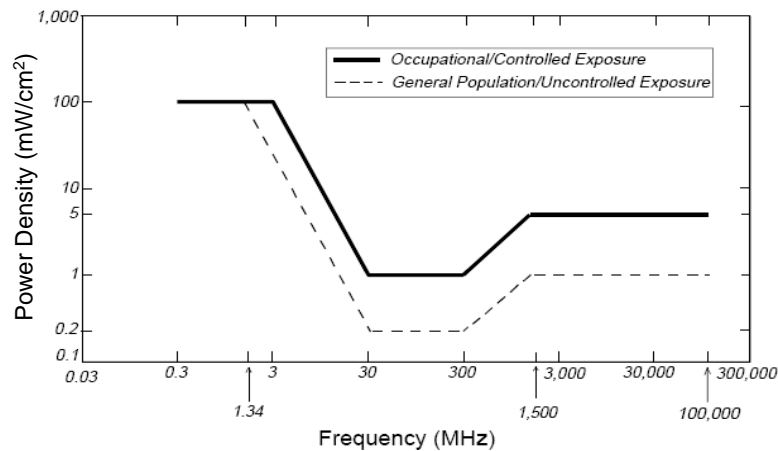

Based on the above, the most restrictive thresholds for exposures of unlimited duration to RF energy for several personal wireless services are summarized below:

Personal Wireless Service	Approximate Frequency	Occupational MPE	Public MPE
Personal Communication (PCS)	1,950 MHz	5.00 mW/cm <sup>2</sup>	1.00 mW/cm <sup>2</sup>
Cellular Telephone	870 MHz	2.90 mW/cm <sup>2</sup>	0.58 mW/cm <sup>2</sup>
Specialized Mobile Radio	855 MHz	2.85 mW/cm <sup>2</sup>	0.57 mW/cm <sup>2</sup>
Most Restrictive Freq. Range	30-300 MHz	1.00 mW/cm <sup>2</sup>	0.20 mW/cm <sup>2</sup>

MPE limits are designed to provide a substantial margin of safety. These limits apply for continuous exposures and are intended to provide a prudent margin of safety for all persons, regardless of age, gender, size, or health.

Personal Communication (PCS) facilities used by Verizon in this area operate within a frequency range of 1900-2100 MHz. Facilities typically consist of: 1) electronic transceivers (the radios or cabinets) connected to wired telephone lines; and 2) antennas that send the wireless signals created by the transceivers to be received by individual subscriber units (PCS telephones). Transceivers are typically connected to antennas by coaxial cables.

Because of the short wavelength of PCS services, the antennas require line-of-site paths for good propagation, and are typically installed above ground level. Antennas are constructed to concentrate energy towards the horizon, with as little energy as possible scattered towards the ground or the sky. This design, combined with the low power of PCS facilities, generally results in no possibility for

exposure to approach Maximum Permissible Exposure (MPE) levels, with the exception of areas directly in front of the antennas.

#### **4.0 WORST-CASE PREDICTIVE MODELING**

EBI has performed theoretical modeling using RoofView® software to estimate the worst-case power density at the site ground-level resulting from operation of the antennas. RoofView® is a widely-used predictive modeling program that has been developed by Richard Tell Associates to predict both near field and far field RF power density values for roof-top and tower telecommunications sites produced by vertical collinear antennas that are typically used in the cellular, PCS, paging and other communications services. The models utilize several operational specifications for different types of antennas to produce a plot of spatially-averaged power densities that can be expressed as a percentage of the applicable exposure limit.

The modeling is based on worst-case assumptions for the number of antennas and transmitter power. The modeling assumes a maximum 2-2 radio configuration for Sectors A and B with a power level of 48 dBm (60 watts) per transmitter for 1900 and 2100 frequencies, in order to provide a worst-case evaluation of predicted MPE levels. The assumptions used in the modeling are based upon information provided by Verizon, and information gathered from other sources. The parameters used for the modeling are summarized in the RoofView® export files presented in Appendix C.

There are no other wireless carriers with equipment installed at this site.

Based on worst-case predictive modeling, there are no modeled areas on any accessible ground-level walking/working surface related to the proposed Verizon antennas that exceed the FCC's occupational or general public exposure limits at this site. At the nearest walking/working surfaces to the Verizon antennas, the maximum power density generated by the Verizon antennas is approximately 7.20 percent of the FCC's general public limit (1.44 percent of the FCC's occupational limit). The composite exposure level from all carriers on this site is approximately 7.20 percent of the FCC's general public limit (1.44 percent of the FCC's occupational limit) at the nearest walking/working surface to each antenna.

The Site Safety Plan also presents areas where Verizon Wireless antennas contribute greater than 5% of the applicable MPE limit for a site. A site is considered out of compliance with FCC regulations if there are areas that exceed the FCC exposure limits and there are no RF hazard mitigation measures in place. Any carrier which has an installation that contributes more than 5% of the applicable MPE must participate in mitigating these RF hazards.

The inputs used in the modeling are summarized in the RoofView® export file presented in Appendix C. A graphical representation of the RoofView® modeling results is presented in Appendix B. It should be noted that RoofView is not suitable for modeling microwave dish antennas; however, these units are designed for point-to-point operations at the elevations of the installed equipment rather than ground level coverage.

## **5.0 MITIGATION/SITE CONTROL OPTIONS**

EBI's modeling indicates that there are no areas in front of the Verizon antennas that exceed the FCC standards for occupational or general public exposure. All exposures above the FCC's safe limits require that individuals be elevated above the ground level. In order to alert people accessing the ground, a Caution sign is recommended for installation 9 feet below antenna bottom facing street.

These protocols and recommended control measures have been summarized and included with a graphic representation of the antennas and associated signage and control areas in a RF-EME Site Safety Plan, which is included as Appendix B. Individuals and workers accessing the roof should be provided with a copy of the attached Site Safety Plan, made aware of the posted signage, and signify their understanding of the Site Safety Plan.

Implementation of the signage recommended in the Site Safety Plan and in this report will bring this site into compliance with the FCC's rules and regulations.

## **6.0 SUMMARY AND CONCLUSIONS**

EBI has prepared a Radiofrequency – Electromagnetic Energy (RF-EME) Compliance Report for telecommunications equipment installed by Verizon Site Number 438510 located at 1021 Lane St in Belmont, California to determine worst-case predicted RF-EME exposure levels from wireless communications equipment installed at this site. This report summarizes the results of RF-EME modeling in relation to relevant Federal Communications Commission (FCC) RF-EME compliance standards for limiting human exposure to RF-EME fields.

As presented in the sections above, based on the FCC criteria, there are no modeled areas on any accessible ground-level walking/working surface related to the proposed antennas that exceed the FCC's occupational or general public exposure limits at this site. Workers should be informed about the presence and locations of antennas and their associated fields. Recommended control measures are outlined in Section 5.0 and within a Site Safety Plan (attached); this plan includes procedures to shut down and lockout/tagout this wireless equipment in accordance with Verizon's standard operating protocol.

## **7.0 LIMITATIONS**

This report was prepared for the use of Verizon Wireless. It was performed in accordance with generally accepted practices of other consultants undertaking similar studies at the same time and in the same locale under like circumstances. The conclusions provided by EBI are based solely on the information provided by the client. The observations in this report are valid on the date of the investigation. Any additional information that becomes available concerning the site should be provided to EBI so that our conclusions may be revised and modified, if necessary. This report has been prepared in accordance with Standard Conditions for Engagement and authorized proposal, both of which are integral parts of this report. No other warranty, expressed or implied, is made.



# **Appendix A**

## **Certifications**

Reviewed and Approved by:



sealed 4feb2018

---

Michael McGuire  
Electrical Engineer

Note that EBI's scope of work is limited to an evaluation of the Radio Frequency – Electromagnetic Energy (RF-EME) field generated by the antennas and broadcast equipment noted in this report. The engineering and design of the structure, as well as the impact of the antennas and broadcast equipment on the structural integrity of the structure, are specifically excluded from EBI's scope of work.

## Preparer Certification





I, Thanh Estevam, state that:

- I am an employee of EnviroBusiness Inc. (d/b/a EBI Consulting), which provides RF-EME safety and compliance services to the wireless communications industry.
- I have successfully completed RF-EME safety training, and I am aware of the potential hazards from RF-EME and would be classified “occupational” under the FCC regulations.
- I am fully aware of and familiar with the Rules and Regulations of both the Federal Communications Commissions (FCC) and the Occupational Safety and Health Administration (OSHA) with regard to Human Exposure to Radio Frequency Radiation.
- I have reviewed the data provided by the client and incorporated it into this Site Compliance Report such that the information contained in this report is true and accurate to the best of my knowledge.

A rectangular box containing a handwritten signature in cursive script that reads "Thanh Estevam".

**Appendix B**  
**Radio Frequency Electromagnetic Energy**  
**Safety / Signage Plans**

**% FCC Public Exposure Limit**

	Exposure Level $\geq$ 5,000
	$500 <$ Exposure Level $\leq$ 5,000
	$100 <$ Exposure Level $\leq$ 500
	Exposure Level $\leq$ 100

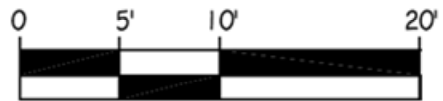
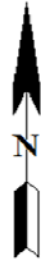

 **Verizon Antennas**

**Roofview: Composite Exposure Levels**

**Facility Operator:** Verizon Wireless

**Site Name:** SF BURLINGAME 019

**Verizon Site Number:** 438510

**Report Date:** 02-04-18

**% FCC Public Exposure Limit**



Exposure Level > 5



Exposure Level ≤ 5

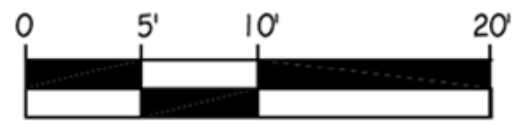
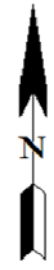
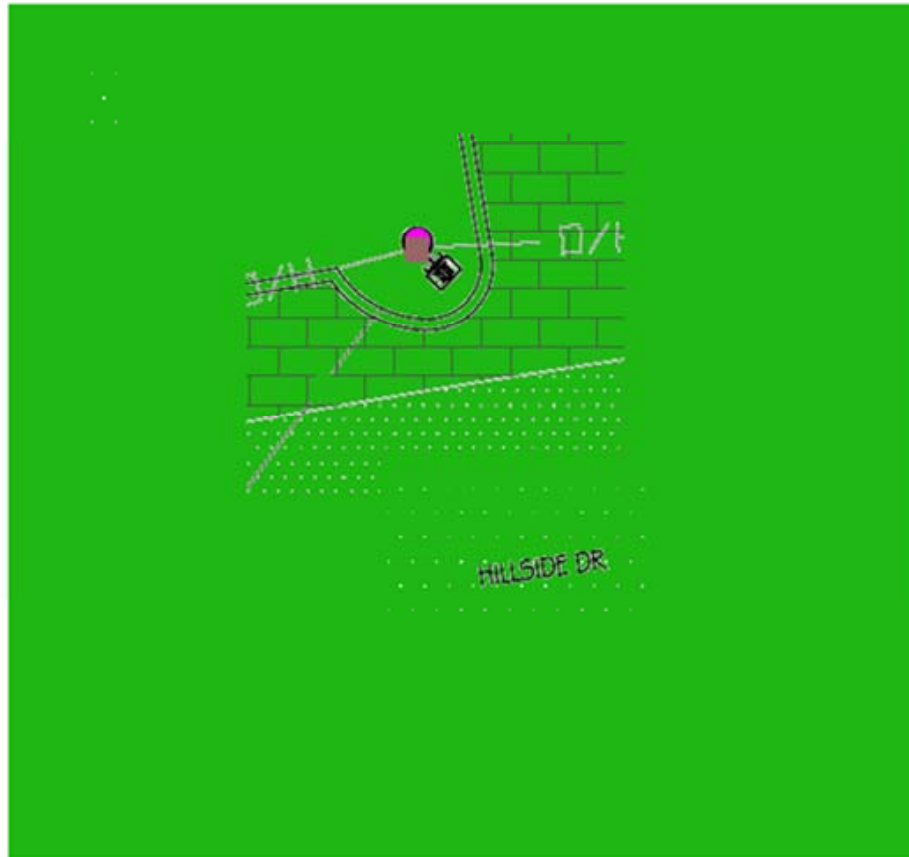

Verizon Antennas

**Roofview: Verizon Exposure Levels**  
Facility Operator: Verizon Wireless  
Site Name: SF BURLINGAME 019  
Verizon Site Number: 438510  
Report Date: 02-04-18

# Verizon Signage Plan

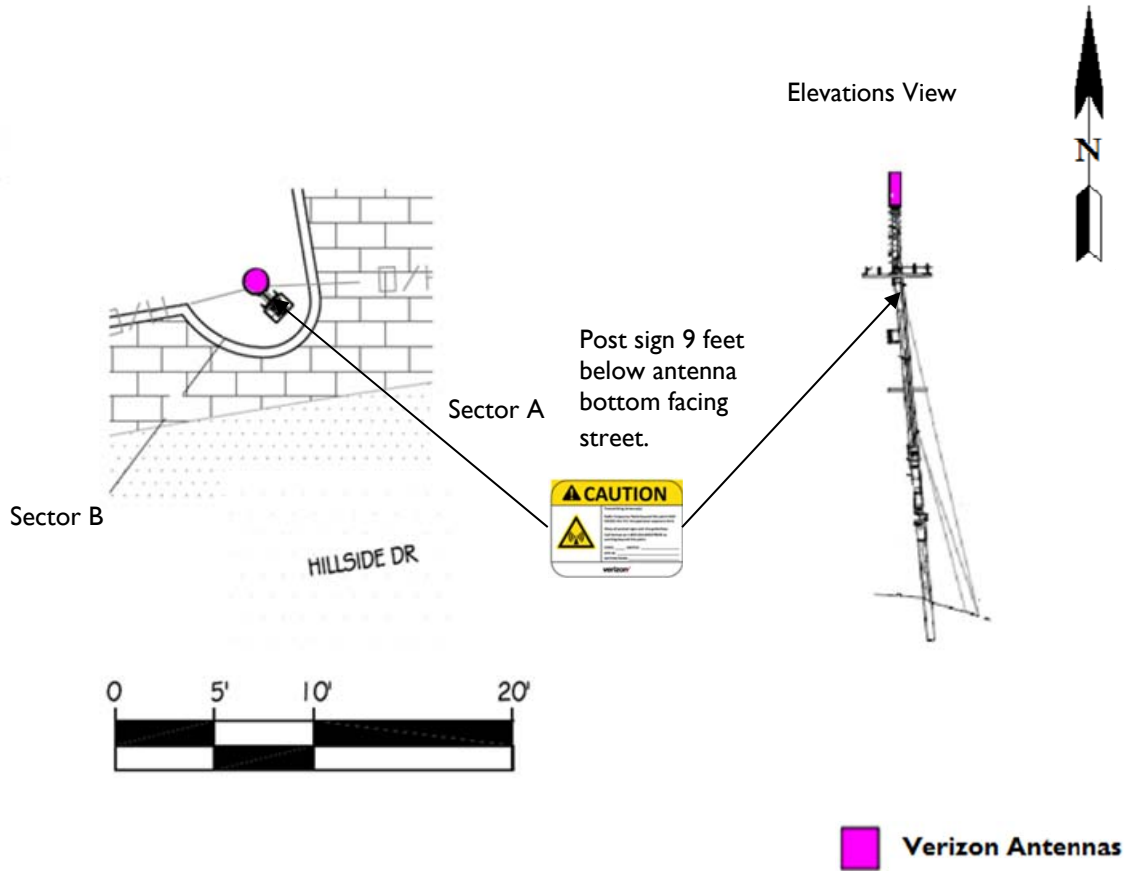

Sign Image	Description	Posting Instructions	Required Signage
	<p><b>Yellow Caution Sign</b> Used to alert individuals that they are entering an area where the power density emitted from transmitting antennas may exceed the FCC's maximum permissible exposure limit for the general public and the occupational exposure limit.</p>	<p>Securely post in a manner conspicuous to all individuals entering thereon as indicated in the signage plan.</p>	<p>Post sign 9 feet below antenna bottom facing street.</p>

# **Appendix C**

## **Roofview® Export File**



**StartMapDefinition**

Roof Max Y Roof Max X Map Max Y Map Max XY Offset X Offset Number of envelope  
 120 120 140 140 20 20 1 \$AE\$81:\$E' \$AE\$81:\$ETS200

**StartSettingsData**

Standard Method Uptime Scale Facto Low Thr Low Color Mid Thr Mid Color Hi Thr Hi Color Over Color Ap Ht Mult Ap Ht Method  
 4 2 1 1 100 1 500 4 5000 2 2 3 1.5 1

**StartAntennaData** It is advisable to provide an ID (ant 1) for all antennas

ID	Name	Freq (MHz)	Trans Power	Trans Count	Coax Len	Coax Type	Other Loss	Input Power	Calc Power	Mfg	Model	X (ft)	Y (ft)	Z (ft)	Type	Aper (ft)	dBd Gain	BWdth Pt Dir	Uptime Profile	ON flag
VZW A1	LTE	1900	60	1	0	0	1			Amphenol	CUUT070X	30	30	45.92		4	6.85	70;110		ON•
VZW A1	LTE	2100	60	1	0	0	1			Amphenol	CUUT070X	30	30	45.92		4	9.85	70;110		ON•
VZW A1	LTE	1900	60	1	0	0	1			Amphenol	CUUT070X	30	30	45.92		4	6.85	70;230		ON•
VZW A1	LTE	2100	60	1	0	0	1			Amphenol	CUUT070X	30	30	45.92		4	9.85	70;230		ON•

**StartSymbolData**

Sym	Map Mark	Roof X	Roof Y	Map Label	Description ( notes for this table only )
Sym		5	35	AC Unit	Sample symbols
Sym		14	5	Roof Access	
Sym		45	5	AC Unit	
Sym		45	20	Ladder	



**County of San Mateo - Planning and Building Department**

# **ATTACHMENT E-1**



SITE NAME: SF REDWOOD CITY 063  
 PROJECT ID: 20171544453  
 LOCATION: 438712  
 ADDRESS: ROW ADJCT 176-798 CANADA RD  
 REDWOOD CITY, CA 94062  
 SITE TYPE: PG&E POLE



SITE INFORMATION	VICINITY MAP	PROJECT TEAM	PROJECT DESCRIPTION																																						
<p>APPLICANT: VERIZON WIRELESS 2785 MITCHELL DRIVE, SUITE #9 WALNUT CREEK, CA 94596</p> <p>AGENT: MODUS, INC 240 STOCKTON STREET, 3RD FLOOR SAN FRANCISCO, CA 94108</p> <p>APH: 093-100-030</p> <p>SITE ADDRESS: 176-798 CANADA RD REDWOOD CITY, CA 94062</p> <p>COUNTY: SAN MATEO</p> <p>LATITUDE: 37° 27' 11.89" N (37.4533028) NAD 83</p> <p>LONGITUDE: 122° 16' 56.33" W (-122.2823139) NAD 83</p> <p>GROUND ELEVATION: ±561.5' AMSL</p> <p>ZONING: PUBLIC ROW</p> <p>ZONING JURISDICTION: REDWOOD CITY</p>		<p>AGENT: KEVIN BOWMER MODUS, INC 240 STOCKTON STREET, 3RD FLOOR SAN FRANCISCO, CA 94108 (408) 219-5442 KBOWMER@MODUS-CORP.COM</p> <p>PROJECT MANAGER: KEVIN BOWMER MODUS, INC 240 STOCKTON STREET, 3RD FLOOR SAN FRANCISCO, CA 94108 (408) 219-5442 KBOWMER@MODUS-CORP.COM</p> <p>CONSTRUCTION MANAGER: CAL BORDONARD MODUS, INC 240 STOCKTON STREET, 3RD FLOOR SAN FRANCISCO, CA 94108 (415) 261-0000 CBORDONARD@MODUS-CORP.COM</p> <p>ARCHITECT/ENGINEER ON RECORD: BRET MCCOMB PRECISION DESIGN &amp; DRAFTING, INC 11765 ATWOOD ROAD, SUITE #20 AUBURN, CA 95603 (530) 823-6546 BRET@PDND.COM</p> <p>VERIZON WIRELESS PROJECT MANAGER: KAREN MCPHERSON VERIZON WIRELESS 2785 MITCHELL DRIVE, SUITE #9 WALNUT CREEK, CA 94596 (925) 200-6320 KAREN.MCPHERSON@VERIZONWIRELESS.COM</p>	<p>THIS IS AN UNMANNED TELECOMMUNICATIONS FACILITY FOR VERIZON WIRELESS CONSISTING OF THE INSTALLATION &amp; OPERATION OF ANTENNAS &amp; ASSOCIATED EQUIPMENT OF AN (E) WOOD JPA POLE IN THE PUBLIC RIGHT OF WAY.</p> <p>SCOPE OF WORK:</p> <ol style="list-style-type: none"> <li>1. INSTALL (N) TELECOMMUNICATIONS EQUIPMENT BOXES ON AN (E) WOOD JPA POLE. EQUIPMENT IS TO BE INSTALLED ON G09S COMPLIANT STANDOFF BRACKET &amp; CONSISTS OF (1) ELECTRICAL METER, (1) AC DISCONNECT, (1) FIBER DMARC, (3) RJ45 W/ PSU UNITS, (2) TWIN DIPLEXERS &amp; (1) CYLINDRICAL ANTENNA.</li> <li>2. ALL EQUIPMENT TO BE PAINTED TO MEET JURISDICTION APPROVAL.</li> <li>3. UTILITY LINES BETWEEN (E) POINT OF CONNECTION &amp; POLE TO BE UNDERGROUND AND/OR OVERHEAD.</li> </ol> <p>DRAWING INDEX</p> <table border="1"> <thead> <tr> <th>SHEET NO:</th> <th>SHEET TITLE</th> </tr> </thead> <tbody> <tr> <td>T-1</td> <td>TITLE SHEET</td> </tr> <tr> <td>T-2</td> <td>GENERAL NOTES, LEGEND, &amp; ABBREVIATIONS</td> </tr> <tr> <td>C-1</td> <td>SITE SURVEY</td> </tr> <tr> <td>A-1</td> <td>SITE PLAN</td> </tr> <tr> <td>A-2</td> <td>EQUIPMENT PLAN &amp; ANTENNA PLANS</td> </tr> <tr> <td>A-3</td> <td>ELEVATIONS</td> </tr> <tr> <td>A-4</td> <td>ELEVATIONS</td> </tr> <tr> <td>A-5</td> <td>DETAILS</td> </tr> <tr> <td>A-6</td> <td>DETAILS</td> </tr> <tr> <td>E-1</td> <td>SINGLE-LINE DIAGRAM &amp; DETAILS</td> </tr> <tr> <td>E-2</td> <td>GROUNDING DIAGRAMS</td> </tr> </tbody> </table>	SHEET NO:	SHEET TITLE	T-1	TITLE SHEET	T-2	GENERAL NOTES, LEGEND, & ABBREVIATIONS	C-1	SITE SURVEY	A-1	SITE PLAN	A-2	EQUIPMENT PLAN & ANTENNA PLANS	A-3	ELEVATIONS	A-4	ELEVATIONS	A-5	DETAILS	A-6	DETAILS	E-1	SINGLE-LINE DIAGRAM & DETAILS	E-2	GROUNDING DIAGRAMS														
SHEET NO:	SHEET TITLE																																								
T-1	TITLE SHEET																																								
T-2	GENERAL NOTES, LEGEND, & ABBREVIATIONS																																								
C-1	SITE SURVEY																																								
A-1	SITE PLAN																																								
A-2	EQUIPMENT PLAN & ANTENNA PLANS																																								
A-3	ELEVATIONS																																								
A-4	ELEVATIONS																																								
A-5	DETAILS																																								
A-6	DETAILS																																								
E-1	SINGLE-LINE DIAGRAM & DETAILS																																								
E-2	GROUNDING DIAGRAMS																																								
<p>CODE COMPLIANCE</p> <p>CONSTRUCTION WORKS &amp; MATERIALS MUST COMPLY WITH ALL APPLICABLE NATIONAL, STATE &amp; LOCAL CODES AS ADOPTED BY LOCAL JURISDICTION, INCLUDING BUT NOT LIMITED TO:</p> <ol style="list-style-type: none"> <li>1. 2016 CALIFORNIA ADMINISTRATIVE CODE (INCL. TITLES 24 &amp; 25)</li> <li>2. 2016 CALIFORNIA BUILDING CODE</li> <li>3. 2016 CALIFORNIA ELECTRICAL CODE</li> <li>4. 2016 CALIFORNIA MECHANICAL CODE</li> <li>5. 2016 CALIFORNIA PLUMBING CODE</li> <li>6. 2016 CALIFORNIA FIRE CODE</li> <li>7. LOCAL BUILDING CODES</li> <li>8. CITY/COUNTY ORDINANCES</li> <li>9. ANSIE/A-TIA-222-G</li> </ol>	<p>DRIVING DIRECTIONS</p> <p>DIRECTIONS FROM VERIZON WIRELESS WALNUT CREEK OFFICE</p> <p>FROM: 2785 MITCHELL DR, WALNUT CREEK, CA 94596        TO: 167-798 CANADA RD, REDWOOD CITY, CA 94062</p> <table border="1"> <tbody> <tr> <td>1. HEAD NORTHEAST ON MITCHELL DR TOWARD OAK GROVE RD</td> <td>30 FT</td> </tr> <tr> <td>2. TURN RIGHT ONTO OAK GROVE RD</td> <td>0.4 MI</td> </tr> <tr> <td>3. TURN RIGHT ONTO YGNACIO VALLEY RD</td> <td>3.6 MI</td> </tr> <tr> <td>4. TURN RIGHT ONTO THE 24 W RAMP TO CHLAND</td> <td>1.2 MI</td> </tr> <tr> <td>5. CONTINUE ONTO CA-24 HIGHWAY 24 W</td> <td>6.1 MI</td> </tr> <tr> <td>6. KEEP LEFT AT THE FORK TO CONTINUE ON CA-24 W</td> <td>1.7 MI</td> </tr> <tr> <td>7. TAKE EXIT 5A FOR HAYWARD TOWARD CA-13 S</td> <td>0.2 MI</td> </tr> <tr> <td>8. MERGE ONTO CA-13 S</td> <td>5.6 MI</td> </tr> <tr> <td>9. MERGE ONTO I-580 E</td> <td>7.5 MI</td> </tr> <tr> <td>10. USE THE RIGHT LANE TO TAKE EXIT 34 FOR CA-238 TOWARD HAYWARD</td> <td>0.3 MI</td> </tr> <tr> <td>11. KEEP RIGHT TO CONTINUE ON EXIT 15, FOLLOW SIGNS FOR I-238 N/800 SAN JOSE/SAN MATEO BRIDGE AND MERGE ONTO I-235 N</td> <td>1.4 MI</td> </tr> <tr> <td>12. TAKE EXIT 16A FOR INTERSTATE 680 S TOWARD SAN JOSE/SAN MATEO BRIDGE</td> <td>1.0 MI</td> </tr> <tr> <td>13. MERGE ONTO I-680 S</td> <td>3.2 MI</td> </tr> <tr> <td>14. TAKE EXIT 57 TO MERGE ONTO CA-90 W TOWARD SAN MATEO BRIDGE/JACKSON ST</td> <td>17.8 MI</td> </tr> <tr> <td>15. TAKE EXIT 6 FOR I-280 N/1-260 S TOWARD SAN JOSE/SAN FRANCISCO</td> <td>0.1 MI</td> </tr> <tr> <td>16. FOLLOW SIGNS FOR INTERSTATE 280/SAN JOSE AND MERGE ONTO I-260 S</td> <td>4.0 MI</td> </tr> <tr> <td>17. TAKE EXIT 29 FOR EDGEWOOD RD</td> <td>0.3 MI</td> </tr> <tr> <td>18. KEEP RIGHT AT THE FORK, FOLLOW SIGNS FOR CANADA RD AND MERGE ONTO EDGEWOOD RD</td> <td>0.4 FT</td> </tr> <tr> <td>19. TURN LEFT ONTO CANADA ROAD</td> <td>1.2 MI</td> </tr> </tbody> </table>	1. HEAD NORTHEAST ON MITCHELL DR TOWARD OAK GROVE RD	30 FT	2. TURN RIGHT ONTO OAK GROVE RD	0.4 MI	3. TURN RIGHT ONTO YGNACIO VALLEY RD	3.6 MI	4. TURN RIGHT ONTO THE 24 W RAMP TO CHLAND	1.2 MI	5. CONTINUE ONTO CA-24 HIGHWAY 24 W	6.1 MI	6. KEEP LEFT AT THE FORK TO CONTINUE ON CA-24 W	1.7 MI	7. TAKE EXIT 5A FOR HAYWARD TOWARD CA-13 S	0.2 MI	8. MERGE ONTO CA-13 S	5.6 MI	9. MERGE ONTO I-580 E	7.5 MI	10. USE THE RIGHT LANE TO TAKE EXIT 34 FOR CA-238 TOWARD HAYWARD	0.3 MI	11. KEEP RIGHT TO CONTINUE ON EXIT 15, FOLLOW SIGNS FOR I-238 N/800 SAN JOSE/SAN MATEO BRIDGE AND MERGE ONTO I-235 N	1.4 MI	12. TAKE EXIT 16A FOR INTERSTATE 680 S TOWARD SAN JOSE/SAN MATEO BRIDGE	1.0 MI	13. MERGE ONTO I-680 S	3.2 MI	14. TAKE EXIT 57 TO MERGE ONTO CA-90 W TOWARD SAN MATEO BRIDGE/JACKSON ST	17.8 MI	15. TAKE EXIT 6 FOR I-280 N/1-260 S TOWARD SAN JOSE/SAN FRANCISCO	0.1 MI	16. FOLLOW SIGNS FOR INTERSTATE 280/SAN JOSE AND MERGE ONTO I-260 S	4.0 MI	17. TAKE EXIT 29 FOR EDGEWOOD RD	0.3 MI	18. KEEP RIGHT AT THE FORK, FOLLOW SIGNS FOR CANADA RD AND MERGE ONTO EDGEWOOD RD	0.4 FT	19. TURN LEFT ONTO CANADA ROAD	1.2 MI	<p>At all services &amp; grounding trenches, provide "WARNING" tape at 12" below grade.</p> <p><b>CALL</b>    "CALL BEFORE YOU DIG"    811/800-227-2600    NATIONWIDE UNDERGROUND SERVICE ALERT</p>	<p>ADMINISTRATIVE REQUIREMENTS</p> <p>CONTRACTOR SHALL VERIFY ALL PLANS &amp; (E) DIMENSIONS &amp; CONDITIONS ON THE JOB SITE &amp; SHALL IMMEDIATELY NOTIFY THE ENGINEER IN WRITING OF ANY DISCREPANCIES BEFORE PROCEEDING WITH THE WORK OR BE RESPONSIBLE FOR SAME IF USING 1" X 1" 17" PLOT, DIMENSIONS WILL BE HALF SCALE.</p>
1. HEAD NORTHEAST ON MITCHELL DR TOWARD OAK GROVE RD	30 FT																																								
2. TURN RIGHT ONTO OAK GROVE RD	0.4 MI																																								
3. TURN RIGHT ONTO YGNACIO VALLEY RD	3.6 MI																																								
4. TURN RIGHT ONTO THE 24 W RAMP TO CHLAND	1.2 MI																																								
5. CONTINUE ONTO CA-24 HIGHWAY 24 W	6.1 MI																																								
6. KEEP LEFT AT THE FORK TO CONTINUE ON CA-24 W	1.7 MI																																								
7. TAKE EXIT 5A FOR HAYWARD TOWARD CA-13 S	0.2 MI																																								
8. MERGE ONTO CA-13 S	5.6 MI																																								
9. MERGE ONTO I-580 E	7.5 MI																																								
10. USE THE RIGHT LANE TO TAKE EXIT 34 FOR CA-238 TOWARD HAYWARD	0.3 MI																																								
11. KEEP RIGHT TO CONTINUE ON EXIT 15, FOLLOW SIGNS FOR I-238 N/800 SAN JOSE/SAN MATEO BRIDGE AND MERGE ONTO I-235 N	1.4 MI																																								
12. TAKE EXIT 16A FOR INTERSTATE 680 S TOWARD SAN JOSE/SAN MATEO BRIDGE	1.0 MI																																								
13. MERGE ONTO I-680 S	3.2 MI																																								
14. TAKE EXIT 57 TO MERGE ONTO CA-90 W TOWARD SAN MATEO BRIDGE/JACKSON ST	17.8 MI																																								
15. TAKE EXIT 6 FOR I-280 N/1-260 S TOWARD SAN JOSE/SAN FRANCISCO	0.1 MI																																								
16. FOLLOW SIGNS FOR INTERSTATE 280/SAN JOSE AND MERGE ONTO I-260 S	4.0 MI																																								
17. TAKE EXIT 29 FOR EDGEWOOD RD	0.3 MI																																								
18. KEEP RIGHT AT THE FORK, FOLLOW SIGNS FOR CANADA RD AND MERGE ONTO EDGEWOOD RD	0.4 FT																																								
19. TURN LEFT ONTO CANADA ROAD	1.2 MI																																								
<p>HANDICAP REQUIREMENTS</p> <p>THIS FACILITY IS UNMANNED &amp; NOT FOR HUMAN HABITATION. HANDICAPPED ACCESS &amp; REQUIREMENTS ARE NOT REQUIRED IN ACCORDANCE WITH CALIFORNIA STATE ADMINISTRATIVE CODE, TITLE 24 PART 2, SECTION 11058.3.4.2, EXCEPTION 1</p>	<p>END AT: 176-798 CANADA RD, REDWOOD CITY, CA 94062</p> <p>ESTIMATED TIME: 1 H 7 MINS ESTIMATED DISTANCE: 50.2 MI</p>	<p>At all services &amp; grounding trenches, provide "WARNING" tape at 12" below grade.</p> <p><b>CALL</b>    "CALL BEFORE YOU DIG"    811/800-227-2600    NATIONWIDE UNDERGROUND SERVICE ALERT</p>	<p>ADMINISTRATIVE REQUIREMENTS</p> <p>CONTRACTOR SHALL VERIFY ALL PLANS &amp; (E) DIMENSIONS &amp; CONDITIONS ON THE JOB SITE &amp; SHALL IMMEDIATELY NOTIFY THE ENGINEER IN WRITING OF ANY DISCREPANCIES BEFORE PROCEEDING WITH THE WORK OR BE RESPONSIBLE FOR SAME IF USING 1" X 1" 17" PLOT, DIMENSIONS WILL BE HALF SCALE.</p>																																						

PRECISION DESIGN  
 Drafting, Inc.  
 Phone: (530) 823-6546 www.pdnd.com  
 11765 Atwood Rd, Suite 20 Auburn, CA 95603



REDWOOD CITY 063

176-798 CANADA RD  
 REDWOOD CITY, CA 94062

ISSUE STATUS

Δ	DATE	DESCRIPTION
	01/22/18	CS 90%

DRAWN BY: T. JONES

CHECKED BY: T. D'CARLO

APPROVED BY: B. McCOMB

DATE: 01/22/18

SHEET TITLE:  
 TITLE SHEET  
 SHEET NUMBER:  
 T-1



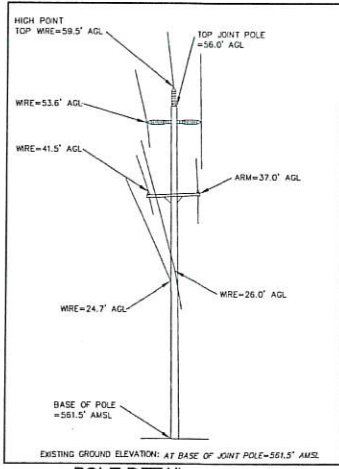

**PROPERTY INFORMATION**

NO: 20171544453  
 SITE: SF REDWOOD CITY 063  
 NEAR APN: 093-140-030  
 REDWOOD CITY, CA 94062

**BASIS OF BEARING**  
 BEARINGS SHOWN HEREON ARE BASED UPON U.S. STATE PLANE NAD83 COORDINATE SYSTEM STATE PLANE COORDINATE ZONE 8, DETERMINED BY GPS OBSERVATIONS.

**BENCHMARK**  
 ELEVATION ESTABLISHED FROM GPS DERIVED ORTHOMETRIC HEIGHTS, APPLYING GEOID 09 SEPARATIONS, CONSTRAINING TO NGS CONTROL STATION 1412' ELEVATION=450.0' (NAVD83)

**SURVEYOR'S NOTES**  
 ALL EASEMENTS CONTAINED IN SAID TITLE REPORT AFFECTING THE IMMEDIATE AREA SURROUNDING THE LEASE HAVE BEEN PLOTTED. SURVEYOR HAS NOT PERFORMED A SEARCH OF PUBLIC RECORDS TO DETERMINE ANY DEFECT IN TITLE ISSUED. THE BOUNDARY SHOWN HEREON IS PLOTTED FROM RECORD INFORMATION AND DOES NOT CONSTITUTE A BOUNDARY SURVEY OF THE PROPERTY.

**LEGEND**

- DI DRAIN INLET
- TFC TOP FACE OF CURB
- R/W RIGHT OF WAY
- EP EDGE OF PAVED DRIVEWAY
- SLT STREET LIGHT SIDEWALK
- TP TOP OF PARAPET
- SH SHEET PILING
- WH WATER VALVE
- WM WATER MANDREL
- WH GEODETIC COORDINATES
- SPOT ELEVATION
- DA DASH ANTENNA
- WC WATER CONTROL VALVE
- FI FIRE HYDRANT
- CC CONDUCTOR FOUND AS NOTED
- LP LIGHT POLE
- ET ELECTRICAL TRANSFORMER
- AC AIR CONDITIONING LINE
- TE TELEPHONE PEDESTAL
- TM TELEPHONE MANHOLE
- GV GAS VALVE
- GM GAS METER
- PL PROPERTY LINE
- CL CHAIN LINK FENCE

**SURVEY DATE**  
 6/15/17

**UTILITY NOTES**  
 SURVEYOR DOES NOT GUARANTEE THAT ALL UTILITIES ARE SHOWN OR THEIR LOCATIONS. IT IS THE RESPONSIBILITY OF THE CONTRACTOR AND DEVELOPER TO CONTACT U.S.A. AND ANY OTHER INVOLVED AGENCIES TO LOCATE ALL UTILITIES PRIOR TO CONSTRUCTION. REMOVAL, RELOCATION AND/OR REPLACEMENT IS THE RESPONSIBILITY OF THE CONTRACTOR.

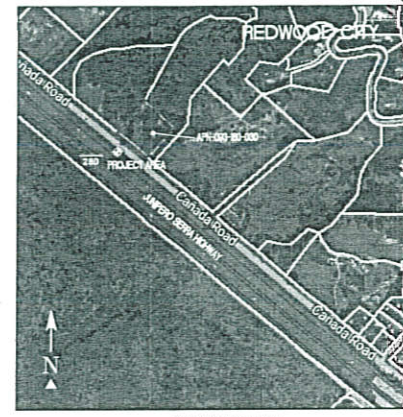

**GEODETIC COORDINATES TAKEN HERE AT JOINT POLE**  
 (NAD 83) 37° 27' 11.95"  
 127° 14' 28.33"

EXISTING GROUND ELEVATION:  
 BASE OF JOINT POLE=561.5' AMSL  
 EXISTING OVERALL HIGH POINT:  
 TOP OF WIRE=59.5' AGL  
 SEE DETAIL ABOVE

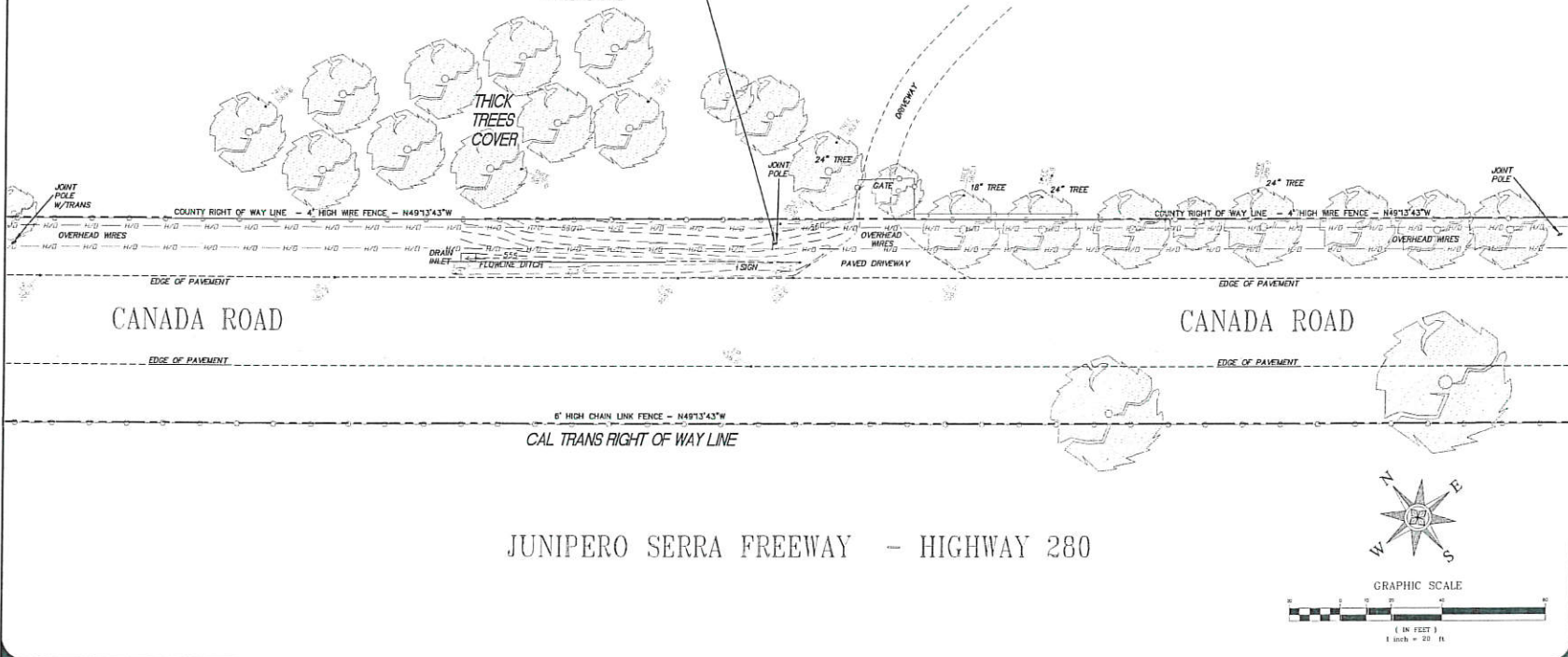

DATE	DESCRIPTION	REVISION
6/25/2017	SITE PLAN	

**HAYES**  
 Land Surveying  
 And Mapping  
 2830 HARMON COURT  
 CONCORD, CA 94519  
 PHONE: (925) 795-5511



**verizon**  
 2785 MITCHELL DRIVE  
 WALNUT CREEK, CA 94598  
 OFFICE: 925-279-6000  
 (925) 279-6333

**TOPOGRAPHIC SURVEY EXISTING CONDITIONS**  
 20171544453  
 SF REDWOOD CITY 063  
 NEAR APN: 093-140-030  
 REDWOOD CITY, CA 94062

C-1  
 SHEET 1 of 1

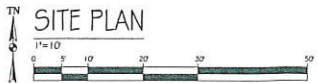
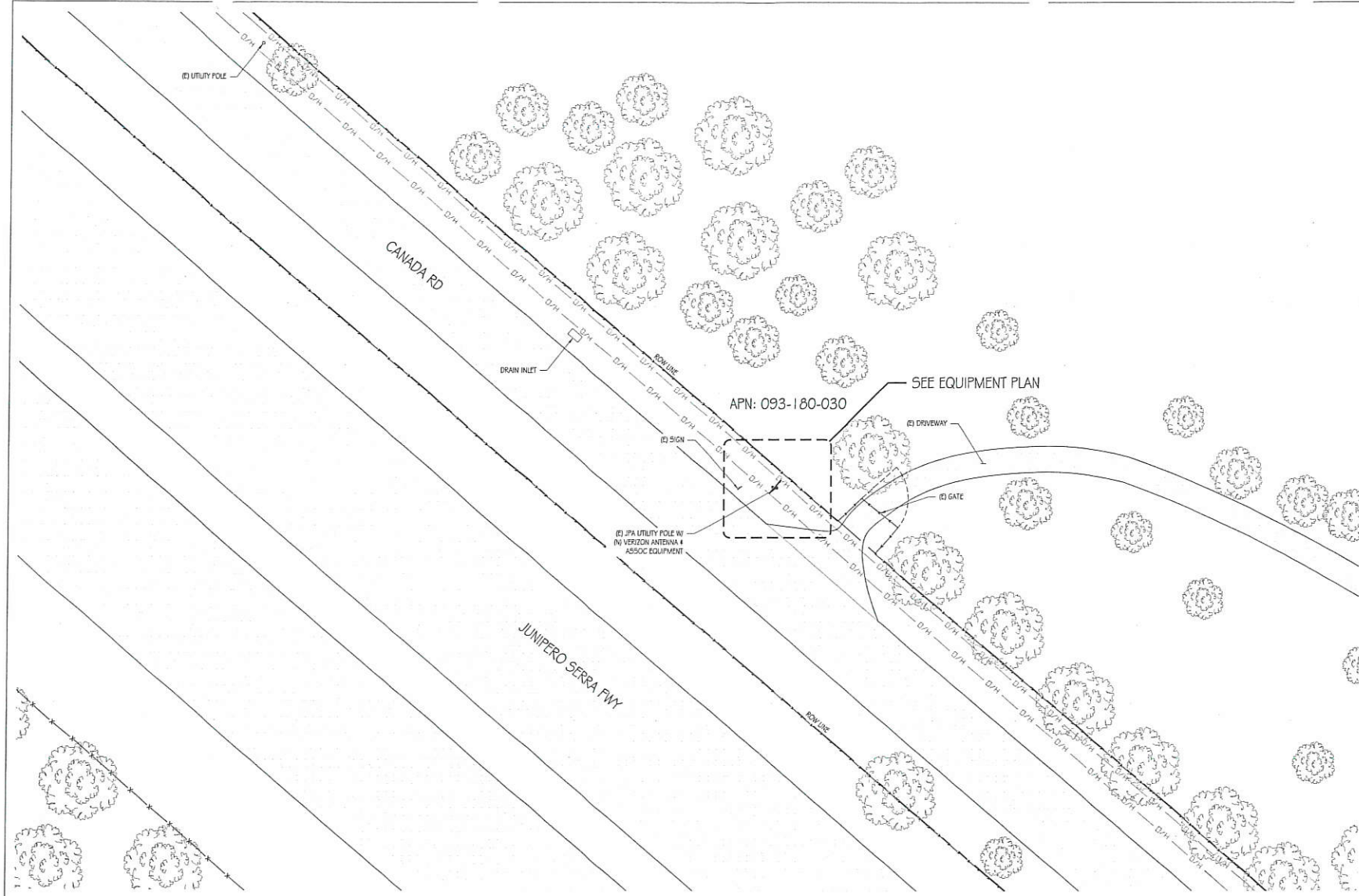

**PRECISION DESIGN & Drafting, INC.**  
 Phone: (831) 823-6646 www.pdinc.com  
 1188 Howard Ave. Suite 20, Watson, CA 95090



**REDWOOD CITY 063**  
 176-798 CANADA RD  
 REDWOOD CITY, CA 94062

**ISSUE STATUS**

Δ	DATE	DESCRIPTION
	01/22/16	CD 30%

DRAWN BY: T. JONES  
 CHECKED BY: T. D'CARLO  
 APPROVED BY: B. MCCOMB  
 DATE: 01/22/16

SHEET TITLE:  
**SITE PLAN**  
 SHEET NUMBER:  
**A-1**

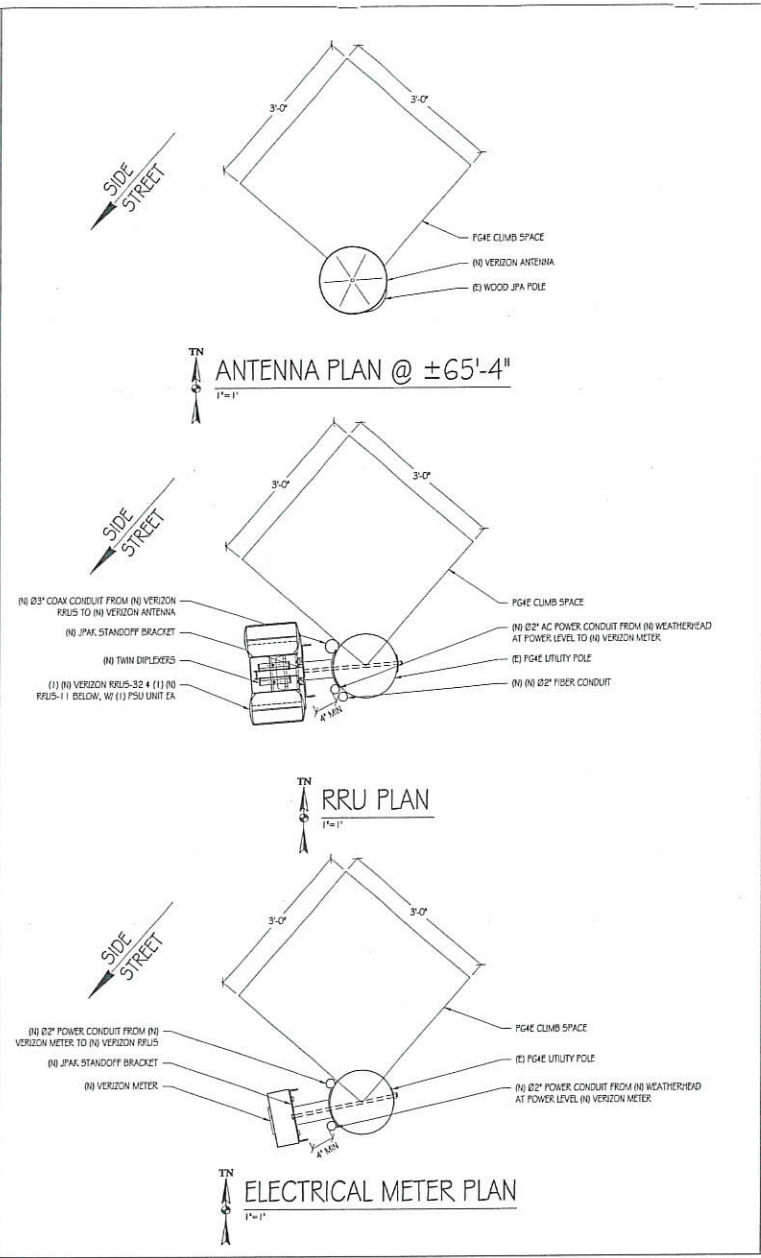
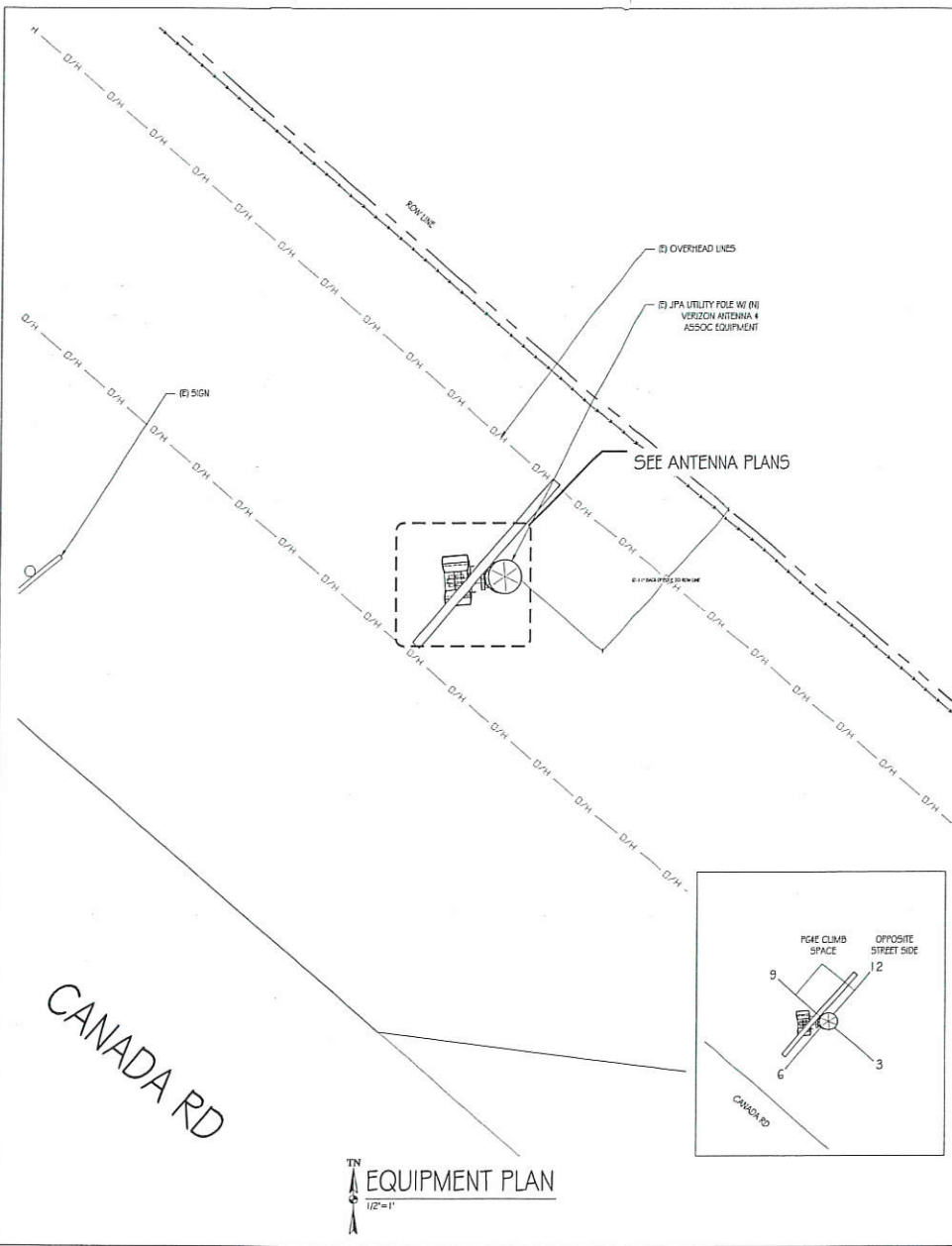

PRECISION DESIGN  
*Engineering, Inc.*  
11708 Alvarado Rd., Suite 20, Oakland, CA 94603  
Phone: (510) 833-6646, www.prd.com

THIS DOCUMENT IS THE PROPERTY OF PRECISION DESIGN ENGINEERING, INC. IT IS TO BE USED ONLY FOR THE PROJECT AND SITE SPECIFICALLY IDENTIFIED HEREIN. IT IS NOT TO BE REPRODUCED, COPIED, OR TRANSMITTED IN ANY FORM OR BY ANY MEANS, ELECTRONIC OR MECHANICAL, INCLUDING PHOTOCOPYING, RECORDING, OR BY ANY INFORMATION STORAGE AND RETRIEVAL SYSTEM, WITHOUT THE WRITTEN PERMISSION OF PRECISION DESIGN ENGINEERING, INC.



REDWOOD CITY 063  
176-790 CANADA RD  
REDWOOD CITY, CA 94062

ISSUE STATUS

Δ	DATE	DESCRIPTION
	01/22/18	CD 50%

DRAWN BY: T. JONES  
CHECKED BY: T. D'CARLO  
APPROVED BY: B. McCOMB  
DATE: 01/22/18

SHEET TITLE:  
EQUIPMENT PLAN & ANTENNA PLANS

SHEET NUMBER:  
A-2

**GENERAL ELECTRICAL NOTES:**

1. PROVIDE ALL ELECTRICAL WORK & MATERIALS AS SHOWN ON THE DWGS, AS CALLED FOR HEREIN, & AS IS NECESSARY TO FURNISH A COMPLETE INSTALLATION.
2. THE INSTALLATION SHALL CONFORM TO THE REQUIREMENTS OF THE CURRENT ADOPTED CALIFORNIA ELECTRICAL CODE, STATE OF CALIFORNIA TITLE 24, ALL OTHER APPLICABLE CODES AND ORDINANCES & THE REQUIREMENTS OF THE FIRE MARSHALL. ALL EQUIPMENT & WIRING SHALL BEAR THE APPROVAL STAMP OF UNDERWRITERS LABORATORY (UL) OR AN APPROVED TESTING LABORATORY, PAYMENT FOR ALL INSPECTION FEES AND PERMITS ARE PART OF THIS CONTRACT.
3. THE CONTRACTOR SHALL BE RESPONSIBLE FOR THE SAFETY AND GOOD CONDITION OF ALL MATERIALS & EQUIPMENT FOR THE ENTIRE INSTALLATION & UNIT COMPLETION OF WORK. ERECT & MAINTAIN APPROVED & SUITABLE BARRIERS, PROTECTIVE DEVICES & WARNING SIGNS, BE FULLY RESPONSIBLE FOR ANY LOSS OR INJURY TO PERSONS OR PROPERTY RESULTING FROM NEGLIGENCE AND/OR ENFORCEMENT OF ALL SAFETY PRECAUTIONS & WARNINGS.
4. COORDINATE THE ELECTRICAL INSTALLATION WITH ALL OTHER TRADES.
5. ALL SAW CUTTING, TRENCHING, BACK FILLING & PATCHING SHALL BE PART OF THIS CONTRACT.
6. FINALIZE ALL ELECTRICAL SERVICE ARRANGEMENTS, INCLUDING VERIFICATION OF LOCATIONS, DETAILS, COORDINATION OF THE INSTALLATION & PAYMENT OF ACCRUED CHARGES WITH LOCAL POWER COMPANY. VERIFY LOCATION FOR FACILITIES & DETAILS WITH POWER UTILITY, IN ADDITION TO THE REQUIREMENTS SHOWN IN THE CONTRACT DOCUMENTS, WORK SHALL COMPLY WITH CONSTRUCTION STANDARDS & SERVICE REQUIREMENTS OF THE RESPECTIVE UTILITIES, INCLUDING ANY SUPPLEMENTAL DWGS ISSUED & SHALL BE SUBJECT TO APPROVAL OF THESE UTILITIES.
7. ALL WIRING SHALL BE COPPER. INSULATION FOR BRANCH CIRCUIT CONDUCTORS SHALL BE TYPE "THW" CONDUCTORS LARGER AND #6 AWG MAY BE TYPE "THWP OR THW".
8. PROVIDE CONDUIT SEALS FOR ALL CONDUITS PENETRATING WEATHERPROOFING OR WEATHERPROOF ENCLOSURE ENVELOPE. MASTIC SEAL ALL CONDUIT OPENING PENETRATIONS COMPLETELY WATERTIGHT.
9. UNLESS SHOWN OTHERWISE, FUSED DISCONNECT SWITCHES SHALL BE PROVIDED WITH LOW-PEAK, SQUARE ELEMENT FUSES SIZED TO EQUIPMENT NAMEPLATE FUSE CURRENT RATING. MOTOR STARTERS SHALL BE PROVIDED WITH SIMILARLY SIZED FUSIBLE ELEMENTS, SWITCHES AND OTHER OUTDOOR EQUIPMENT SHALL BE RATED NEMA 3R AND/OR UL LISTED FOR WET ENVIRONMENT.
10. THE CONTRACTOR SHALL BE RESPONSIBLE FOR TESTING THE GROUNDING SYSTEM AND ENSURING A 5 OHM OR LESS GROUNDING PATH, ADDITIONAL GROUND RODS AND/OR CHEMICAL ROD SYSTEM SHALL BE USED TO ACHIEVE THIS REQUIREMENT IF THE GIVEN DESIGN CANNOT BE MADE TO ACHIEVE THIS REQUIREMENT.

**POWER AND TELCO NOTES:**

1. POWER AND TELCO POINTS OF CONNECTION AND ANY EASEMENTS ARE PRELIMINARY AND SUBJECT TO CHANGE BY THE UTILITY COMPANIES.
2. CONTRACTOR SHALL COORDINATE WITH UTILITY COMPANY FOR FINAL AND EXACT WORK/MATERIALS REQUIREMENTS AND CONSTRUCT TO UTILITY ENGINEERING PLANS AND SPECIFICATIONS ONLY WHERE APPLICABLE PER PROJECT SCOPE OF WORK.
3. CONTRACTOR SHALL FURNISH AND INSTALL CONDUIT, PULL WIRES, CABLE PULL BOXES, CONCRETE ENCASUREMENT OF CONDUIT, TRANSFORMER PAD, BARRIERS, POLE RISER, TRENCHING, BACK FILL, AND UTILITY FEES, AND INCLUDE REQUIREMENTS IN SCOPE.
4. CONTRACTOR SHALL LABEL ALL MAIN DISCONNECT SWITCHES AS REQUIRED BY CODE.
5. CONTRACTOR SHALL PROVIDE METER WITH DIST. PANEL AND BREAKERS FOR POWER TO THE BTS UNITS AND THE BTS/ UTILITY CABINET.
6. ALL SERVICE EQUIPMENT AND INSTALLATIONS SHALL COMPLY WITH THE N.E.C. AND UTILITY COMPANY AND LOCAL CODE REQUIREMENTS.
7. CONTRACTOR SHALL PROVIDE ELECTRICAL SERVICE ENTRANCE EQUIPMENT WITH FAULT CURRENT RATINGS GREATER THAN THE AVAILABLE FAULT CURRENT FROM THE POWER UTILITY.
8. FIELD ROUTE CONDUIT TO CABINETS AS REQUIRED.
9. MAXIMUM ONE WAY CIRCUIT RUN NOT TO EXCEED 75 FEET.

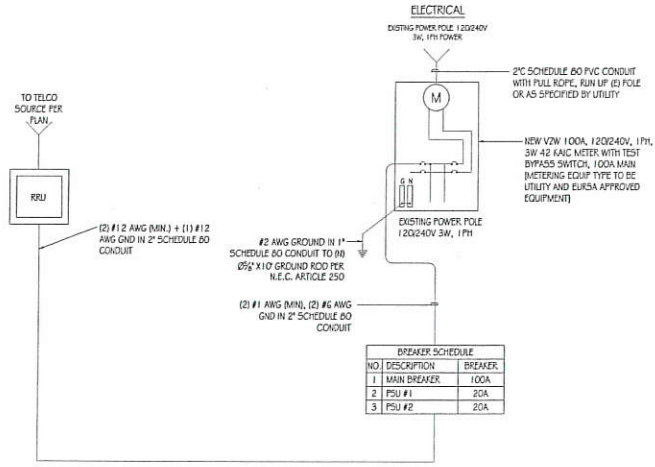

**SINGLE-LINE DIAGRAM**

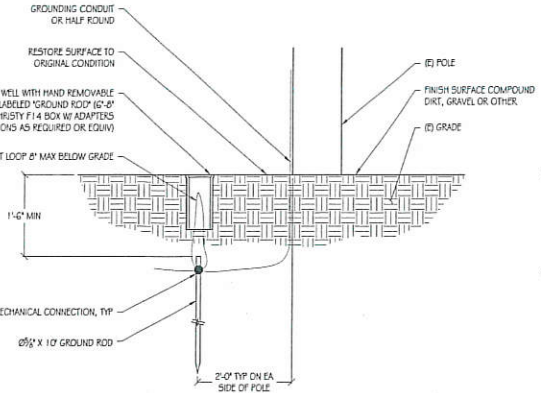

- NOTES:**
1. IF GROUND ROD IS INSTALLED ON SIDEWALK AREA, CORE DRILL SIDEWALK PRIOR TO INSTALLING INSPECTION WELL
  2. EXPOSED CONCRETE TO HAVE BROOM FINISH

**1 POLE GROUNDING DETAIL**  
NTS

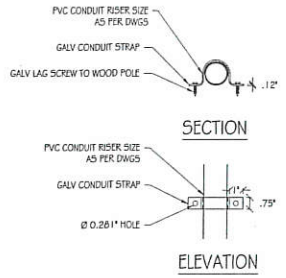

**2 CONDUIT RISER DETAIL**  
NTS

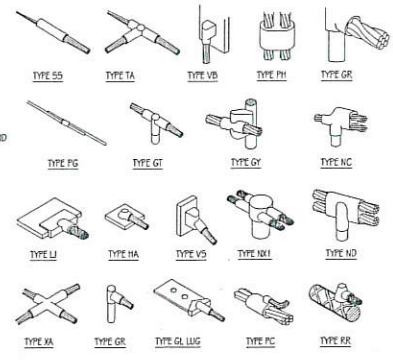

**3 EXOTHERMIC WELD DETAILS**  
NTS

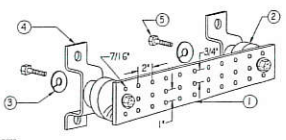

- NOTES:**
1. GALVANIZED STEEL GROUND BAR, HOLE CENTERS TO MATCH NEMA DOUBLE LUG CONFIGURATION. (ACTUAL GROUND BAR SIZE WILL VARY BASED ON NUMBER OF GROUND CONNECTIONS)
  2. INSULATORS, NEWTON INSTRUMENT CAT. NO. 30G1-4 OR APPROVED EQUAL
  3. 5/8" LOCK WASHERS, NEWTON INSTRUMENT CO., CAT. NO. 3015-8 OR APPROVED EQUAL
  4. WALL MOUNTING BRACKET, NEWTON INSTRUMENT CO., CAT. NO. A-6256 OR APPROVED EQUAL
  5. 5/8-11 X 1" 1" INCS BOLTS, NEWTON INSTRUMENT CO., CAT. NO. 3012-1 OR APPROVED EQUAL
  6. INSULATORS SHALL BE ELIMINATED WHEN BONDING DIRECTLY TO TOWER/MONOPINE STRUCTURE. CONNECTION TO TOWER/MONOPINE STRUCTURE SHALL BE PER MANUFACTURER'S RECOMMENDATIONS.

**4 GROUND BAR DETAIL**  
NTS

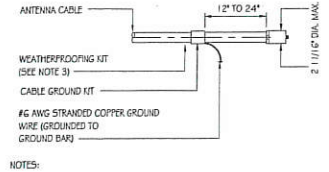

- NOTES:**
1. DO NOT INSTALL CABLE GROUND KIT AT A BEND AND ALWAYS DIRECT GROUND WIRE DOWN TO GROUND BAR.
  2. GROUNDING KIT SHALL BE TYPE AND PART NUMBER AS SUPPLIED OR RECOMMENDED BY CABLE MANUFACTURER.
  3. WEATHER PROOFING SHALL BE (TYPE AND PART NUMBER AS SUPPLIED OR RECOMMENDED BY CABLE MANUFACTURER.)

**5 GND KIT DETAIL**  
NTS

**verizon**

VERIZON WIRELESS  
27180 MIDFIELD DRIVE, SUITE #2  
DUBLIN, CALIF. 94568



240 SEVENTH STREET, 3RD FLOOR  
SAN FRANCISCO, CA 94103

**PRECISION DESIGN**  
*Engineering*  
INC.

Phone: (925) 622-6246 www.prd.com  
11768 Alvarado Rd., Suite #2, Dublin, CA 95023



**REDWOOD CITY 063**

176-798 CANADA RD  
REDWOOD CITY, CA 94062

**ISSUE STATUS**

Δ	DATE	DESCRIPTION
	01/22/18	CD 50%

DRAWN BY: T. JONES  
CHECKED BY: T. D'CARLO  
APPROVED BY: B. McCOMB  
DATE: 01/22/18

SHEET TITLE:  
**SINGLE-LINE DIAGRAM & DETAILS**

SHEET NUMBER:  
**E-1**



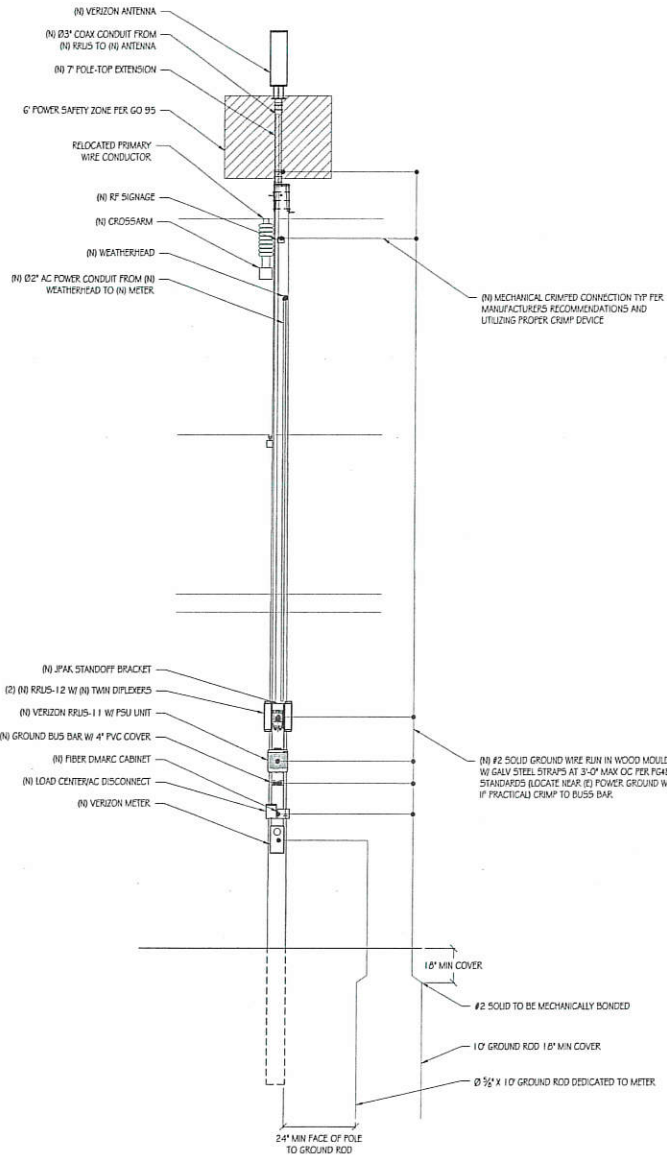

POLE GROUNDING DIAGRAM  
 NTS

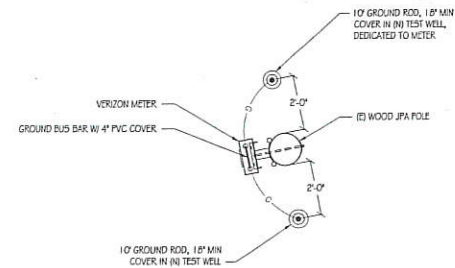

TN  
 NTS  
 GROUNDING PLAN



VERIZON WIRELESS  
 2785 MITCHELL BRIDGE, SUITE #9  
 WINDY CREEK, CA 94595



240 S. DIVISADERO ST. 3RD FLOOR  
 SAN FRANCISCO, CA 94116

PRECISION DESIGN  
 & ENGINEERING, INC.  
 Phone: (510) 832-6644 www.pdeng.com  
 11708 Alameda Rd., Suite 207 Alhambra, CA 91803



REDWOOD CITY 063

176-758 CANADA RD  
 REDWOOD CITY, CA 94062

ISSUE STATUS

Δ	DATE	DESCRIPTION
	01/22/16	CD 50%

DRAWN BY: T. JONES  
 CHECKED BY: T. DICARLO  
 APPROVED BY: B. MCCOMB  
 DATE: 01/22/16  
 SHEET TITLE:

GROUNDING DIAGRAMS

SHEET NUMBER

E-2



**County of San Mateo - Planning and Building Department**

# **ATTACHMENT E-2**

*Existing*



*Proposed*



view from Canada Road looking northwest at site

Existing

view from Canada Road looking east at site



438712 SF Redwood City 063  
Adjacent to 176-798 Canada Road, Redwood City, CA  
Photosims Produced on 2-3-2018

Proposed

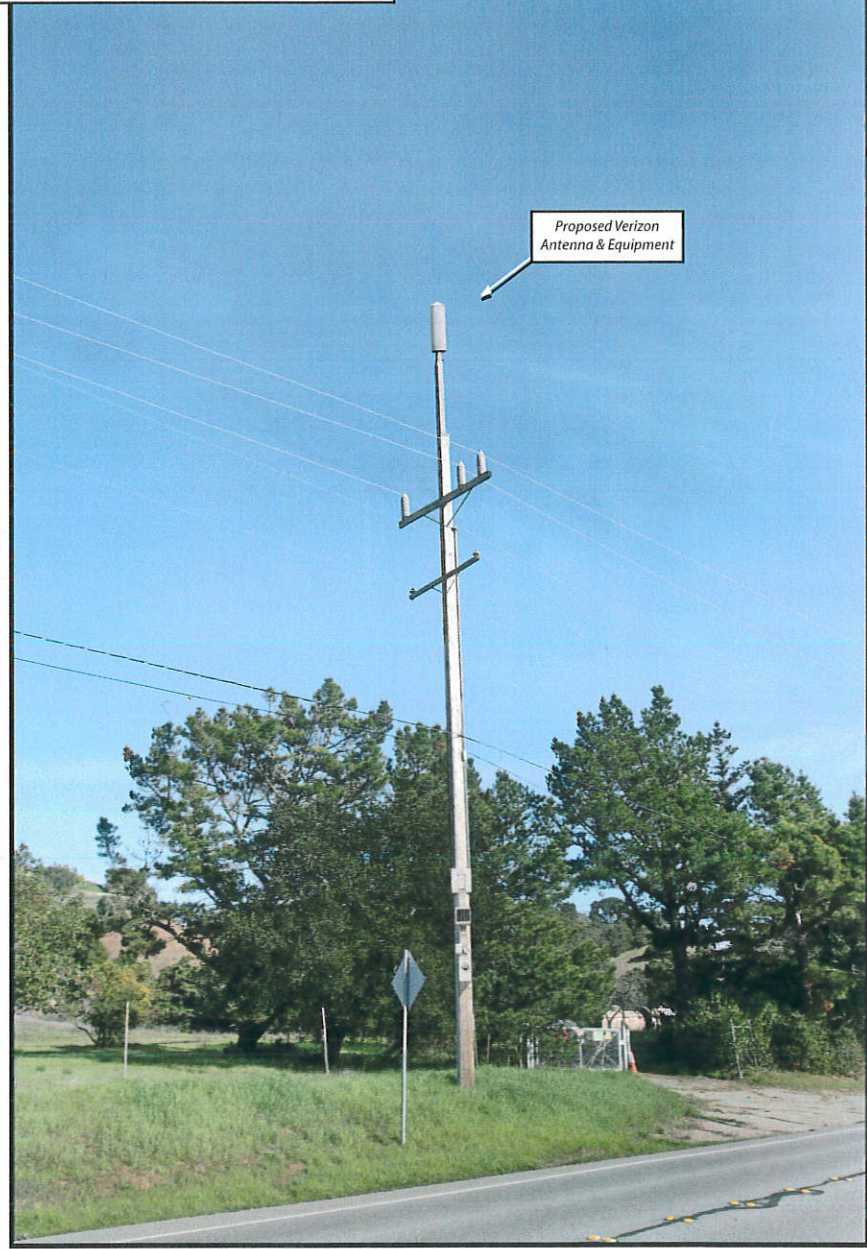

Proposed Verizon  
Antenna & Equipment



**County of San Mateo - Planning and Building Department**

# **ATTACHMENT E-3**



PG&E Wood Utility Pole:  
Pole is viable but potentially  
too far from area desired  
coverage area

PG&E Wood Utility Pole:  
Pole is potentially viable and  
would need some tree  
abatement

SITE SELECTED

PG&E Wood Utility Pole: Pole  
is viable

PG&E Wood Utility Pole: Too  
busy, the pole does not have  
open quadrants for  
equipment and installation

PG&E Wood Utility Pole: pole  
is viable but too far from area  
RF wishes to cover



**County of San Mateo - Planning and Building Department**

# **ATTACHMENT E-4**

# Radio Frequency - Electromagnetic Energy (RF-EME) Jurisdictional Report

---

Site No. 428712  
SF Redwood City 063  
ROW Adjct 176-798 Canada Rd  
Redwood City, California 94062  
San Mateo County  
37° 27' 11.89" N, -122° 16' 56.33" W NAD83

EBI Project No. 6218000822  
February 14, 2018

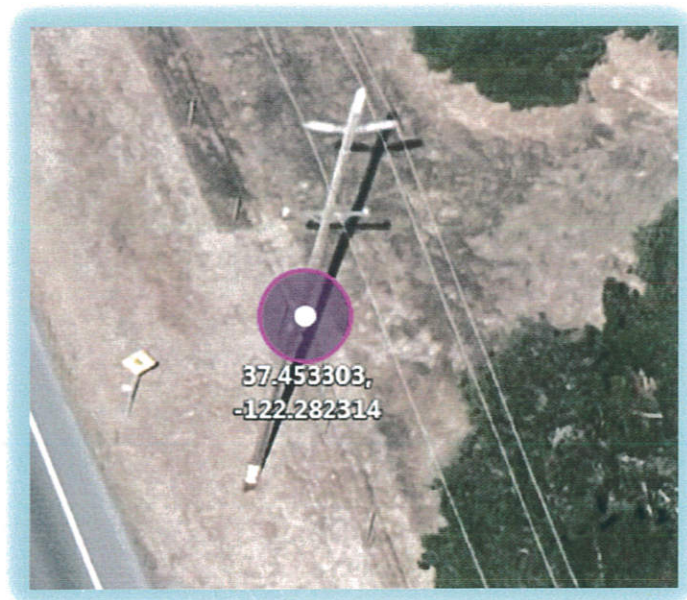

Prepared for:  
Verizon Wireless  
c/o Modus, Inc.  
115 Sansome Street, 14<sup>th</sup> Floor  
San Francisco, CA 94104

Prepared by:





**TABLE OF CONTENTS**

**EXECUTIVE SUMMARY..... 1**  
**1.0 INTRODUCTION.....2**  
**2.0 SITE DESCRIPTION .....2**  
**3.0 FEDERAL COMMUNICATIONS COMMISSION (FCC) REQUIREMENTS.....2**  
**4.0 WORST-CASE PREDICTIVE MODELING.....5**  
**5.0 MITIGATION/SITE CONTROL OPTIONS .....6**  
**6.0 SUMMARY AND CONCLUSIONS .....6**  
**7.0 LIMITATIONS .....6**

**APPENDICES**

- APPENDIX A CERTIFICATIONS**
- APPENDIX B RADIO FREQUENCY ELECTROMAGNETIC ENERGY SAFETY / SIGNAGE PLANS**
- APPENDIX C ROOFVIEW® EXPORT FILES**

## EXECUTIVE SUMMARY

### Purpose of Report

EnviroBusiness Inc. (dba EBI Consulting) has been contracted by Verizon Wireless to conduct radio frequency electromagnetic (RF-EME) modeling for Verizon Site 428712 located at ROW Adjct 176-798 Canada Rd in Redwood City, California to determine RF-EME exposure levels from proposed Verizon wireless communications equipment at this site. As described in greater detail in Section 2.0 of this report, the Federal Communications Commission (FCC) has developed Maximum Permissible Exposure (MPE) Limits for general public exposures and occupational exposures. This report summarizes the results of RF-EME modeling in relation to relevant FCC RF-EME compliance standards for limiting human exposure to RF-EME fields.

### Statement of Compliance

A site is considered out of compliance with FCC regulations if there are areas that exceed the FCC exposure limits and there are no RF hazard mitigation measures in place. Any carrier which has an installation that contributes more than 5% of the applicable MPE must participate in mitigating these RF hazards.

As presented in the sections below, based on worst-case predictive modeling, there are no modeled areas on any accessible ground-level walking/working surface related to the proposed antennas that exceed the FCC's occupational or general public exposure limits at this site. Additionally, there are areas where workers who may be elevated above the ground may be exposed to power densities greater than the occupational limits. Therefore, workers should be informed about the presence and locations of antennas and their associated fields.

At the nearest walking/working surfaces to the Verizon antennas, the maximum power density generated by the Verizon antennas is approximately **3.00** percent of the FCC's general public limit (**0.60** percent of the FCC's occupational limit).

The composite exposure level from all carriers on this site is approximately **3.00** percent of the FCC's general public limit (**0.60** percent of the FCC's occupational limit) at the nearest walking/working surface to each antenna.

Recommended control measures are outlined in Section 5.0 and within a Site Safety Plan (attached); this plan includes instructions to shut down and lockout/tagout this wireless equipment in accordance with Verizon's standard operating protocol.

## 1.0 INTRODUCTION

Radio frequency waves are electromagnetic waves from the portion of the electromagnetic spectrum at frequencies lower than visible light and microwaves. The wavelengths of radio waves range from thousands of meters to around 30 centimeters. These wavelengths correspond to frequencies as low as 3 cycles per seconds (or hertz [Hz]) to as high as one gigahertz (one billion cycles per second).

Personal Communication (PCS) facilities used by Verizon in this area operate within a frequency range of 700-2100 MHz. Facilities typically consist of: 1) electronic transceivers (the radios or cabinets) connected to wired telephone lines; and 2) antennas that send the wireless signals created by the transceivers to be received by individual subscriber units (PCS telephones). Transceivers are typically connected to antennas by coaxial cables.

Because of the short wavelength of PCS services, the antennas require line-of-site paths for good propagation, and are typically installed a distance above ground level. Antennas are constructed to concentrate energy towards the horizon, with as little energy as possible scattered towards the ground or the sky. This design, combined with the low power of PCS facilities, generally results in no possibility for exposure to approach Maximum Permissible Exposure (MPE) levels, with the exception of in areas in the immediate vicinity of the antennas.

MPE limits do not represent levels where a health risk exists, since they are designed to provide a substantial margin of safety. These limits apply for continuous exposures and are intended to provide a prudent margin of safety for all persons, regardless of age, gender, size or health.

## 2.0 SITE DESCRIPTION

This project site includes one (1) wireless telecommunication antenna on a utility pole located at ROW Adjct 176-798 Canada Rd in Redwood City, California.

Verizon Antenna Information (proposed Configuration)									
Antenna # and Model	Frequency (MHz)	# of Transmitters	Transmit Power (Watts)	Azimuth	Gain (dBd)	Feet above Ground (CL)	X	Y	Z (feet)
AI Amphenol CUUB180X12Fxyz0	700	2	60	130°	7.35	65.33	30	30	63.33
	1900	2	60		11.65				
	2100	2	60	310°	11.65				

The FCC guidelines incorporate two separate tiers of exposure limits that are based upon occupational/controlled exposure limits (for workers) and general population/uncontrolled exposure limits for members of the general public that may be exposed to antenna fields. While access to this site is considered uncontrolled, the analysis has considered exposures with respect to both controlled and uncontrolled limits as an untrained worker may access adjacent rooftop locations. Additional information regarding controlled/uncontrolled exposure limits is provided in Section 3.0. Appendix B presents a site safety plan that provides a plan view of the utility pole with antenna locations.

## 3.0 FEDERAL COMMUNICATIONS COMMISSION (FCC) REQUIREMENTS

The FCC has established Maximum Permissible Exposure (MPE) limits for human exposure to Radiofrequency Electromagnetic (RF-EME) energy fields, based on exposure limits recommended by the National Council on Radiation Protection and Measurements (NCRP) and, over a wide range of

frequencies, the exposure limits developed by the Institute of Electrical and Electronics Engineers, Inc. (IEEE) and adopted by the American National Standards Institute (ANSI) to replace the 1982 ANSI guidelines. Limits for localized absorption are based on recommendations of both ANSI/IEEE and NCRP.

The FCC guidelines incorporate two separate tiers of exposure limits that are based upon occupational/controlled exposure limits (for workers) and general public/uncontrolled exposure limits for members of the general public.

**Occupational/controlled exposure limits** apply to situations in which persons are exposed as a consequence of their employment and in which those persons who are exposed have been made fully aware of the potential for exposure and can exercise control over their exposure. Occupational/controlled exposure limits also apply where exposure is of a transient nature as a result of incidental passage through a location where exposure levels may be above general public/uncontrolled limits (see below), as long as the exposed person has been made fully aware of the potential for exposure and can exercise control over his or her exposure by leaving the area or by some other appropriate means.

**General public/uncontrolled exposure limits** apply to situations in which the general public may be exposed or in which persons who are exposed as a consequence of their employment may not be made fully aware of the potential for exposure or cannot exercise control over their exposure. Therefore, members of the general public would always be considered under this category when exposure is not employment-related, for example, in the case of a telecommunications tower that exposes persons in a nearby residential area.

Table I and Figure I (below), which are included within the FCC's OET Bulletin 65, summarize the MPE limits for RF emissions. These limits are designed to provide a substantial margin of safety. They vary by frequency to take into account the different types of equipment that may be in operation at a particular facility and are "time-averaged" limits to reflect different durations resulting from controlled and uncontrolled exposures.

The FCC's MPEs are measured in terms of power (mW) over a unit surface area (cm<sup>2</sup>). Known as the power density, the FCC has established an occupational MPE of 5 milliwatts per square centimeter (mW/cm<sup>2</sup>) and an uncontrolled MPE of 1 mW/cm<sup>2</sup> for equipment operating in the 1900 MHz frequency range. For the Verizon equipment operating at 700 MHz or 850 MHz, the FCC's occupational MPE is 2.83 mW/cm<sup>2</sup> and an uncontrolled MPE of 0.57 mW/cm<sup>2</sup>. These limits are considered protective of these populations.

Table I: Limits for Maximum Permissible Exposure (MPE)				
(A) Limits for Occupational/Controlled Exposure				
Frequency Range (MHz)	Electric Field Strength (E) (V/m)	Magnetic Field Strength (H) (A/m)	Power Density (S) (mW/cm <sup>2</sup> )	Averaging Time [E] <sup>2</sup> , [H] <sup>2</sup> , or S (minutes)
0.3-3.0	614	1.63	(100)*	6
3.0-30	1842/f	4.89/f	(900/f <sup>2</sup> )*	6
30-300	61.4	0.163	1.0	6
300-1,500	--	--	f/300	6
1,500-100,000	--	--	5	6
(B) Limits for General Public/Uncontrolled Exposure				

Frequency Range (MHz)	Electric Field Strength (E) (V/m)	Magnetic Field Strength (H) (A/m)	Power Density (S) (mW/cm <sup>2</sup> )	Averaging Time [E] <sup>2</sup> , [H] <sup>2</sup> , or S (minutes)
0.3-1.34	614	1.63	(100)*	30
1.34-30	824/f	2.19/f	(180/f <sup>2</sup> )*	30
30-300	27.5	0.073	0.2	30
300-1,500	--	--	f/1,500	30
1,500-100,000	--	--	1.0	30

f = Frequency in (MHz)

\* Plane-wave equivalent power density

Figure 1. FCC Limits for Maximum Permissible Exposure (MPE)

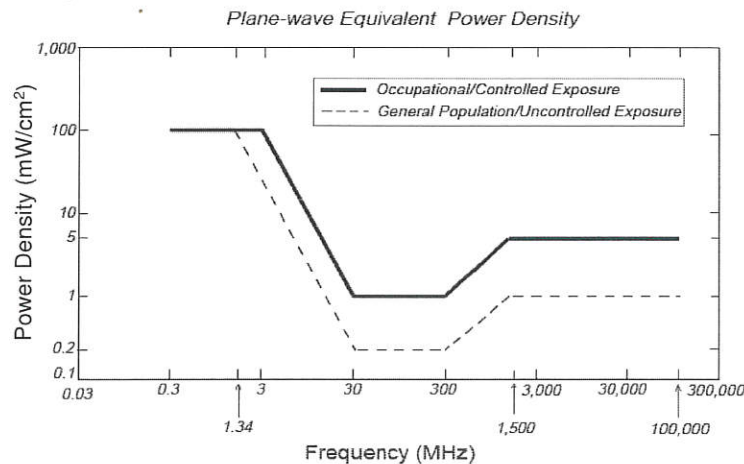

Based on the above, the most restrictive thresholds for exposures of unlimited duration to RF energy for several personal wireless services are summarized below:

Personal Wireless Service	Approximate Frequency	Occupational MPE	Public MPE
Personal Communication (PCS)	1,950 MHz	5.00 mW/cm <sup>2</sup>	1.00 mW/cm <sup>2</sup>
Cellular Telephone	870 MHz	2.90 mW/cm <sup>2</sup>	0.58 mW/cm <sup>2</sup>
Specialized Mobile Radio	855 MHz	2.85 mW/cm <sup>2</sup>	0.57 mW/cm <sup>2</sup>
Most Restrictive Freq. Range	30-300 MHz	1.00 mW/cm <sup>2</sup>	0.20 mW/cm <sup>2</sup>

MPE limits are designed to provide a substantial margin of safety. These limits apply for continuous exposures and are intended to provide a prudent margin of safety for all persons, regardless of age, gender, size, or health.

Personal Communication (PCS) facilities used by Verizon in this area operate within a frequency range of 700-2100 MHz. Facilities typically consist of: 1) electronic transceivers (the radios or cabinets) connected to wired telephone lines; and 2) antennas that send the wireless signals created by the transceivers to be received by individual subscriber units (PCS telephones). Transceivers are typically connected to antennas by coaxial cables.

Because of the short wavelength of PCS services, the antennas require line-of-site paths for good propagation, and are typically installed above ground level. Antennas are constructed to concentrate energy towards the horizon, with as little energy as possible scattered towards the ground or the sky. This design, combined with the low power of PCS facilities, generally results in no possibility for

exposure to approach Maximum Permissible Exposure (MPE) levels, with the exception of areas directly in front of the antennas.

#### **4.0 WORST-CASE PREDICTIVE MODELING**

EBI has performed theoretical modeling using RoofView® software to estimate the worst-case power density at the site ground-level and nearby rooftops resulting from operation of the antennas. RoofView® is a widely-used predictive modeling program that has been developed by Richard Tell Associates to predict both near field and far field RF power density values for roof-top and tower telecommunications sites produced by vertical collinear antennas that are typically used in the cellular, PCS, paging and other communications services. The models utilize several operational specifications for different types of antennas to produce a plot of spatially-averaged power densities that can be expressed as a percentage of the applicable exposure limit.

The modeling is based on worst-case assumptions for the number of antennas and transmitter power. The modeling assumes a maximum 2-2 radio configuration for Sector A with a power level of 46 dBm (40 watts) per transmitter for 700 and 2100 frequencies, in order to provide a worst-case evaluation of predicted MPE levels. The assumptions used in the modeling are based upon information provided by Verizon, and information gathered from other sources. The parameters used for the modeling are summarized in the RoofView® export files presented in Appendix C.

There are no other wireless carriers with equipment installed at this site.

Based on worst-case predictive modeling, there are no modeled areas on any accessible ground-level walking/working surface related to the proposed Verizon antennas that exceed the FCC's occupational or general public exposure limits at this site. At the nearest walking/working surfaces to the Verizon antennas, the maximum power density generated by the Verizon antennas is approximately 3.00 percent of the FCC's general public limit (0.60 percent of the FCC's occupational limit). The composite exposure level from all carriers on this site is approximately 3.00 percent of the FCC's general public limit (0.60 percent of the FCC's occupational limit) at the nearest walking/working surface to each antenna.

The Site Safety Plan also presents areas where Verizon Wireless antennas contribute greater than 5% of the applicable MPE limit for a site. A site is considered out of compliance with FCC regulations if there are areas that exceed the FCC exposure limits and there are no RF hazard mitigation measures in place. Any carrier which has an installation that contributes more than 5% of the applicable MPE must participate in mitigating these RF hazards.

The inputs used in the modeling are summarized in the RoofView® export file presented in Appendix C. A graphical representation of the RoofView® modeling results is presented in Appendix B. It should be noted that RoofView is not suitable for modeling microwave dish antennas; however, these units are designed for point-to-point operations at the elevations of the installed equipment rather than ground level coverage.

## **5.0 MITIGATION/SITE CONTROL OPTIONS**

EBI's modeling indicates that there are no areas in front of the Verizon antennas that exceed the FCC standards for occupational or general public exposure. All exposures above the FCC's safe limits require that individuals be elevated above the ground. In order to alert people accessing the ground a Caution sign is recommended for installation approximately 10 feet below the antenna facing the street.

There are no barriers recommended on this site.

These protocols and recommended control measures have been summarized and included with a graphic representation of the antennas and associated signage and control areas in a RF-EME Site Safety Plan, which is included as Appendix B. Individuals and workers accessing the roof should be provided with a copy of the attached Site Safety Plan, made aware of the posted signage, and signify their understanding of the Site Safety Plan.

Implementation of the signage recommended in the Site Safety Plan and in this report will bring this site into compliance with the FCC's rules and regulations.

## **6.0 SUMMARY AND CONCLUSIONS**

EBI has prepared a Radiofrequency – Electromagnetic Energy (RF-EME) Compliance Report for telecommunications equipment installed by Verizon Site Number 428712 located at ROW Adjct 176-798 Canada Rd in Redwood City, California to determine worst-case predicted RF-EME exposure levels from wireless communications equipment installed at this site. This report summarizes the results of RF-EME modeling in relation to relevant Federal Communications Commission (FCC) RF-EME compliance standards for limiting human exposure to RF-EME fields.

As presented in the sections above, based on the FCC criteria, there are no modeled areas on any accessible ground-level walking/working surface related to the proposed antennas that exceed the FCC's occupational or general public exposure limits at this site. Based on worst-case predictive modeling, the maximum power density may exceed the FCC's general public MPE limits within approximately 10 feet of the antenna face. Workers should be informed about the presence and locations of antennas and their associated fields. Recommended control measures are outlined in Section 5.0 and within a Site Safety Plan (attached); this plan includes procedures to shut down and lockout/tagout this wireless equipment in accordance with Verizon's standard operating protocol.

## **7.0 LIMITATIONS**

This report was prepared for the use of Verizon Wireless. It was performed in accordance with generally accepted practices of other consultants undertaking similar studies at the same time and in the same locale under like circumstances. The conclusions provided by EBI are based solely on the information provided by the client. The observations in this report are valid on the date of the investigation. Any additional information that becomes available concerning the site should be provided to EBI so that our conclusions may be revised and modified, if necessary. This report has been prepared in accordance with Standard Conditions for Engagement and authorized proposal, both of which are integral parts of this report. No other warranty, expressed or implied, is made.

## **Appendix A**

### **Certifications**



## Preparer Certification

I, Andrew Simpson, state that:

- I am an employee of EnviroBusiness Inc. (d/b/a EBI Consulting), which provides RF-EME safety and compliance services to the wireless communications industry.
- I have successfully completed RF-EME safety training, and I am aware of the potential hazards from RF-EME and would be classified "occupational" under the FCC regulations.
- I am fully aware of and familiar with the Rules and Regulations of both the Federal Communications Commissions (FCC) and the Occupational Safety and Health Administration (OSHA) with regard to Human Exposure to Radio Frequency Radiation.
- I have reviewed the data provided by the client and incorporated it into this Site Compliance Report such that the information contained in this report is true and accurate to the best of my knowledge.



Andrew Simpson

Reviewed and Approved by:

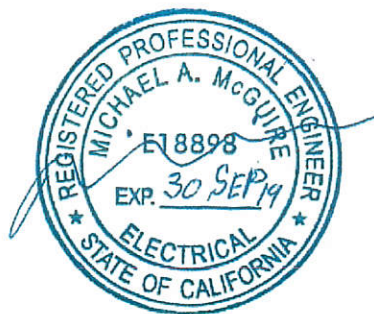

sealed 15feb2018





---

Michael McGuire  
Electrical Engineer

Note that EBI's scope of work is limited to an evaluation of the Radio Frequency – Electromagnetic Energy (RF-EME) field generated by the antennas and broadcast equipment noted in this report. The engineering and design of the structure, as well as the impact of the antennas and broadcast equipment on the structural integrity of the structure, are specifically excluded from EBI's scope of work.

**Appendix B**  
**Radio Frequency Electromagnetic Energy**  
**Safety / Signage Plans**

**% FCC Public Exposure Limit**

	Exposure Level $\geq$ 5,000
	500 < Exposure Level $\leq$ 5,000
	100 < Exposure Level $\leq$ 500
	Exposure Level $\leq$ 100

**\*Antenna Face Simulation**

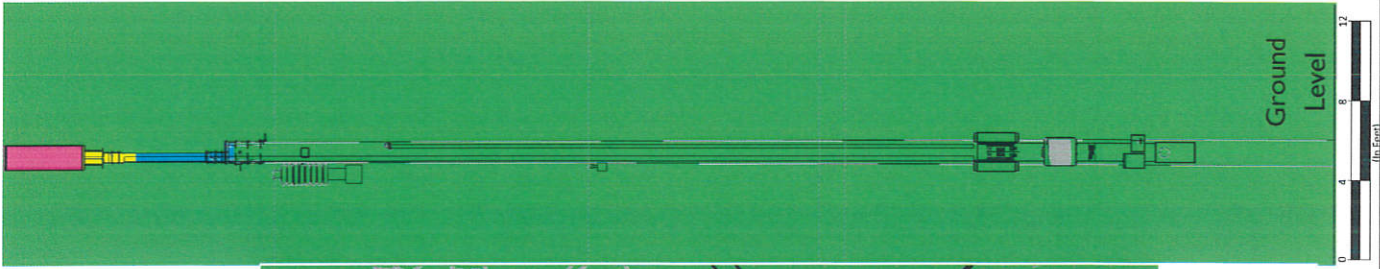
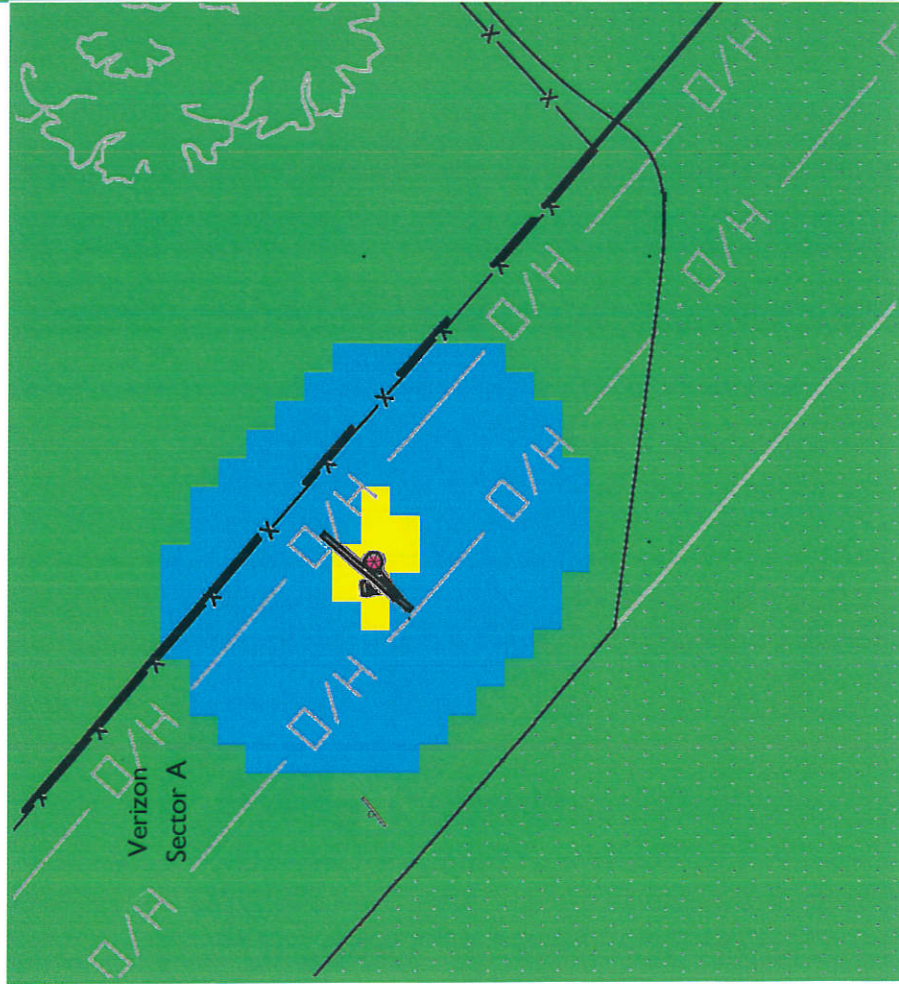

**Roofview: Composite Exposure Levels**

Facility Operator: Verizon Wireless

Site Name: SF Redwood City 063

Verizon Site Number: 428712

Report Date: 02-14-18

 Verizon Antennas

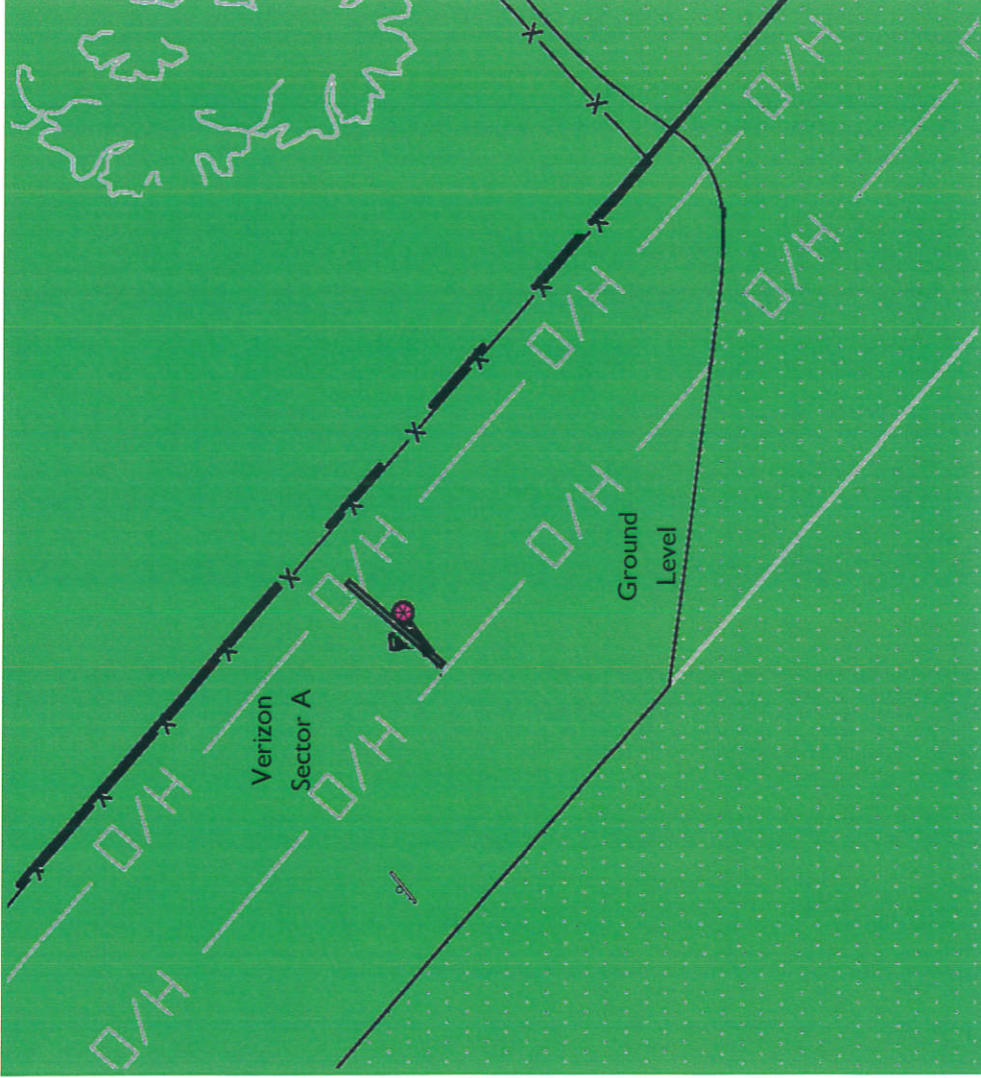

% FCC Public Exposure Limit	
<span style="display: inline-block; width: 15px; height: 15px; background-color: lightblue; border: 1px solid black;"></span>	Exposure Level > 5
<span style="display: inline-block; width: 15px; height: 15px; background-color: lightgreen; border: 1px solid black;"></span>	Exposure Level ≤ 5

\*Ground Level Simulation

**Roofview: Verizon Exposure Levels**  
 Facility Operator: Verizon Wireless  
 Site Name: SF Redwood City 063  
 Verizon Site Number: 428712  
 Report Date: 02-14-18



Verizon Antennas

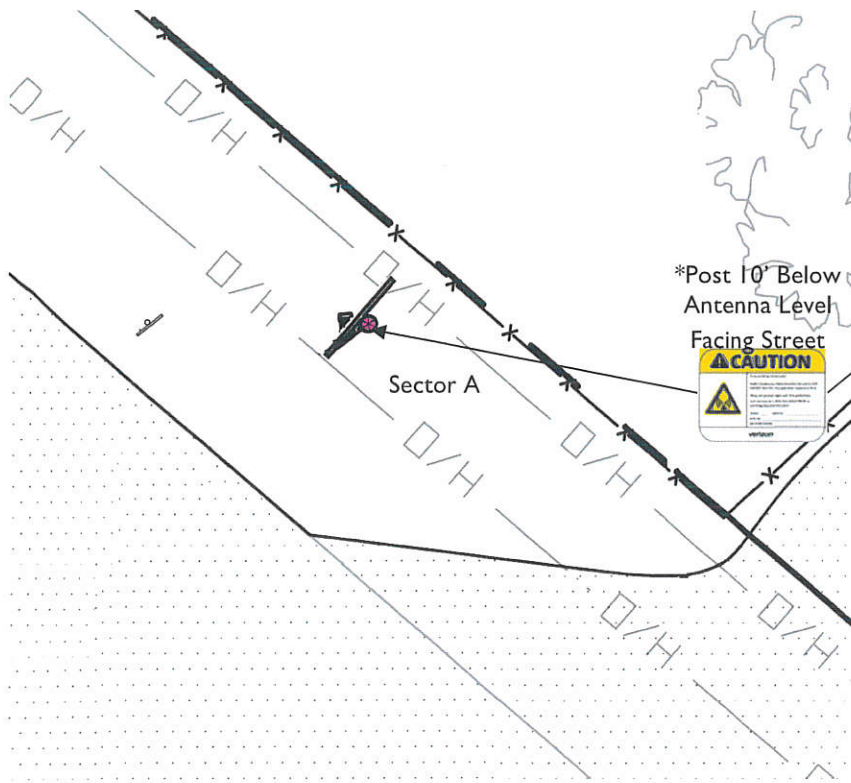



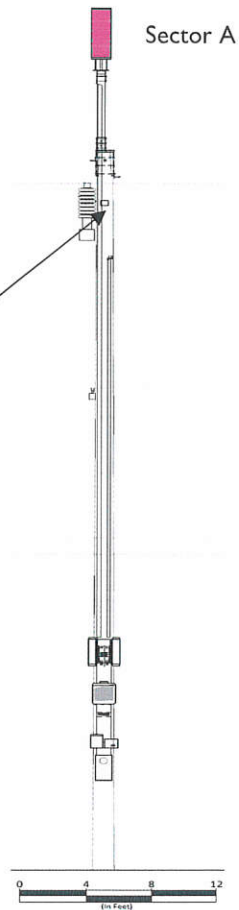

\*Post 10' Below Antenna Level Facing Street



Verizon Antennas



Sign Image	Description	Posting Instructions	Required Signage
	<b>Notice To Workers</b> Informational sign, used to notify workers that there are active antennas installed and provide guidelines for working in RF environments.	N/A	No Required.
	<b>NOC Information Sign</b> Informational sign with NOC Phone Number and Base Transceiver Station (BTS) Number	N/A	No Required.
	<b>Blue Notice Sign</b> Used to alert individuals that they are entering an area where the power density emitted from transmitting antennas exceeds the FCC's maximum permissible exposure limit for the general public but is less than the occupational exposure limit.	N/A	No Required.
	<b>Yellow Caution Sign</b> Used to alert individuals that they are entering an area where the power density emitted from transmitting antennas may exceed the FCC's maximum permissible exposure limit for the general public and the occupational exposure limit.	Securely post 10' below the antenna in a manner conspicuous to all individuals entering thereon as indicated in the signage plan.	Post 10' Below Antenna Level Facing Street
	<b>Red Warning Sign</b> Used to alert individuals that they are entering an area where the power density emitted from the transmitting is substantially above the FCC's maximum permissible limit for occupational exposure (greater than ten times the Occupational limit).	N/A	No Required.

## **Appendix C**

### **Roofview® Export File**

Map, Settings, Antenna, and Symbol Data Table .. Exported from workbook -> RoofView 4.15.xls  
Done on 7/16/2014 at 4:24:55 PM.

Use this format to prepare other data sets for the RoofView workbook file.  
You may use as many rows in this TOP header as you wish.

The critical point are the cells in COLUMN ONE that read 'Start...' (eg. StartMapDefinition)  
If used, these (4) headers are required to be spelled exactly, as one word (eg. StartMapDefinition)

The very next row will be considered the start of that data block.  
The first row of the data block can be a header (as shown below), but this is optional.  
When building a text file for import, Add the Map info first, then the Antenna data, followed by the symbol data  
All rows above the first marker line 'Start...' will be ignored, no matter how many there are.

This area is for you use for documentation.

End of help comments.

You can place as much text here as you wish as long as you don't place it below  
the Start Map Definition row below the blue line.

You may insert more rows using the Insert menu.

Should you need additional lines to document your project, simply insert additional rows  
by highlighting the row number adjacent to the blue line below and then clicking on the Insert menu  
and selecting rows.

**StartMapDefinition**

Roof Max \ Roof Max \ Map Max \ Y Offset X Offset Number of envelope  
120 120 140 140 20 20 1 \$AES81:SE \$AES81:SET\$200

**StartSettingsData**

Standard Method Uptime Scale Fact Low Thr Low Color Mid Thr Mid Color Hi Thr Hi Color Over Color Ap Ht Mult Ap Ht Method  
4 2 1 100 1 500 2 5000 2 3 1.5 1

**StartAntennaData**

It is advisable to provide an ID (ant 1) for all antennas

ID	Name	Freq (MHz)	Uptime	Trans Power	Trans Count	Coax Len	Coax Type	Other Loss	Input Power	Calc Power	Mfg Model	X (ft)	Y (ft)	Z (ft)	Type	Aper (ft)	dBd Gain	BWdth Pt Dir	Uptime Profile	ON flag
VZW A1	LTE	700	60	1.0	0	0	0	1	1	1	Amphenol CUUB180X	30	30	30	63.33	4	7.35 180;130	ON*		
VZW A1	LTE	1900	60	1.0	0	0	0	1	1	1	Amphenol CUUB180X	30	30	30	63.33	4	11.65 180;130	ON*		
VZW A1	LTE	2100	60	1.0	0	0	0	1	1	1	Amphenol CUUB180X	30	30	30	63.33	4	11.65 180;130	ON*		
VZW A1	LTE	700	60	1.0	0	0	0	1	1	1	Amphenol CUUB180X	30	30	30	63.33	4	7.35 180;310	ON*		
VZW A1	LTE	1900	60	1.0	0	0	0	1	1	1	Amphenol CUUB180X	30	30	30	63.33	4	11.65 180;310	ON*		
VZW A1	LTE	2100	60	1.0	0	0	0	1	1	1	Amphenol CUUB180X	30	30	30	63.33	4	11.65 180;310	ON*		

List Of Area  
\$AES81:SE

**StartSymbolData**

Sym	Map Mark	Roof X	Roof Y	Map Label	Description ( notes for this table only )
Sym	5	35	AC Unit	Sample symbols	
Sym	14	5	Roof Access		
Sym	45	5	AC Unit		
Sym	45	20	Ladder		