

**COUNTY OF SAN MATEO  
PLANNING AND BUILDING DEPARTMENT**

**DATE:** June 20, 2024

**TO:** Zoning Hearing Officer

**FROM:** Planning Staff

**SUBJECT:** Consideration of Use Permit Renewal and Amendment, pursuant to Section 6500 and 6513 of the San Mateo County Zoning Regulations, to allow the modification of the existing T-Mobile cellular facility, including removal of three antennas and replacement with six panel antennas, to be located inside a 10 feet by 10 feet by 9 feet tall fiberglass reinforced plastic (FRP) screened enclosure, on the rooftop of an existing apartment building located at 201 4th Avenue, in the Unincorporated North Fair Oaks area of San Mateo County.

County File Number: PLN1999-00511 (T- Mobile)

**PROPOSAL**

The applicant proposes to renew and amend the Use Permit for the facility to allow the continued operation, modification, and expansion of an existing T-Mobile telecommunication facility on the rooftop of a residential apartment building. The existing facility consists of three panel antennas inside a 10 feet 5 inches by 2 feet 4 inches radome Fiberglass Reinforced Plastic (FRP) screen, with six Tower Mounted Amplifier (TMAs), and two ground-mounted cabinets within a 10-square foot enclosure. The existing ground cabinets are 5 feet 3 inches tall and are not visible from the street due to the existing 6-foot-tall property fence. The existing antennas, Radome FRP screen, Remote Radio Unit (RRUs), and the TMAs would be removed. Figures 1, 2 and 4 below shows the existing conditions at the site.



Figure 1 Location of Existing rooftop Antenna and ground cabinets

The applicant proposes to amend the Use Permit by removing the existing three antennas and replacing with six antennas inside a new 10 feet by 10 feet by 9 feet tall FRP screen. Other improvements include removing the existing ground cabinet and replacing it with two new equipment cabinets within the same footprint, with a total of four cabinets at the site; installing a new 200 Amp PG&E meter/main, installing a new 200 Amp-rated conduit/conductor to the equipment area, and a new 200 Amp power protection cabinet with an AC service panel. Figures 3 and 4 shows the proposal.

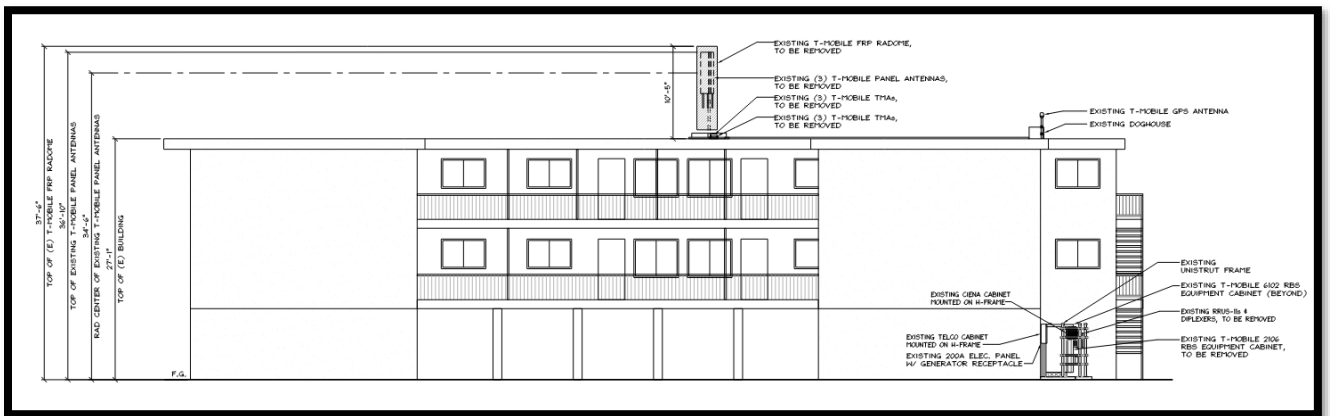

Figure 2 Existing Southeast Elevation

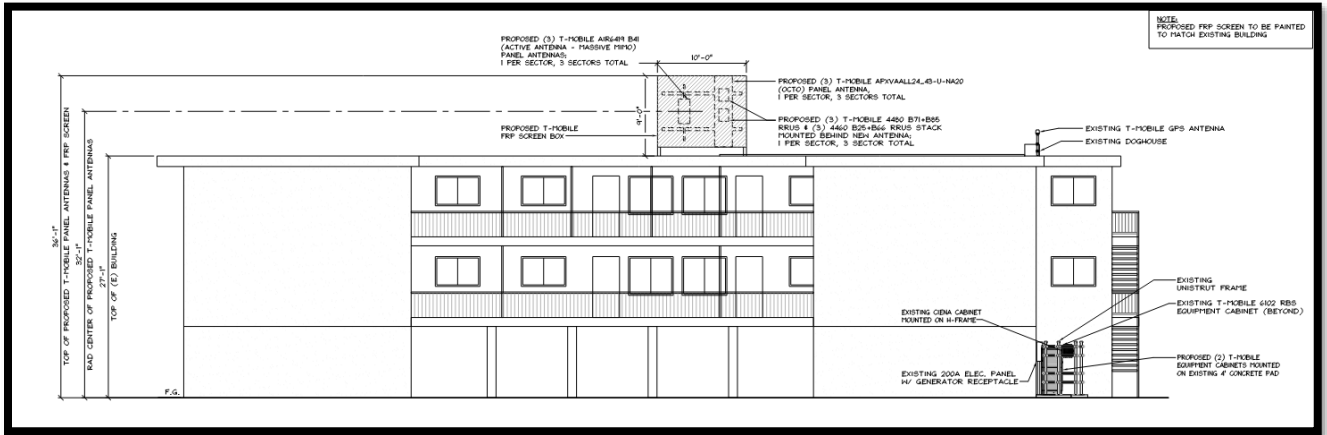

Figure 3 Proposed Southeast Elevation

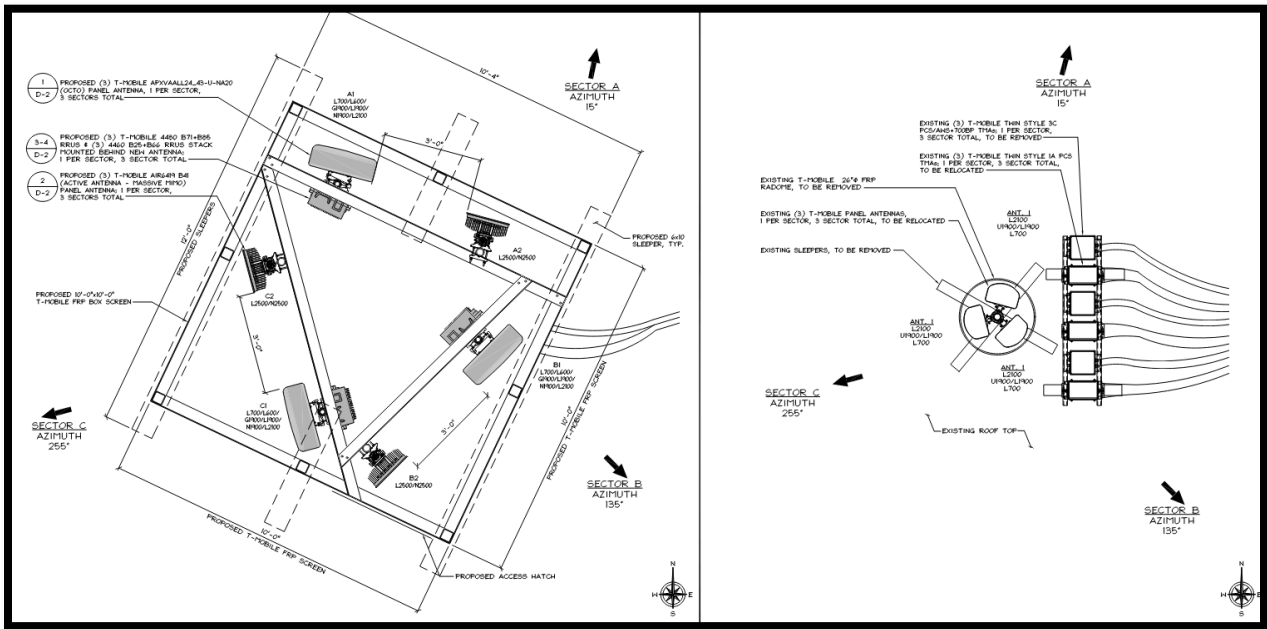

Figure 4 Existing and Proposed Antennas Layout

## RECOMMENDATION

Approve the Use Permit Renewal and Amendment, County File Number PLN 1999-00511, by making the required findings and adopting the conditions of approval listed in Attachment A.

## **BACKGROUND**

Report Prepared By: Sonal Aggarwal, Planner III, Project Planner

Applicant: Network Connex on behalf of T-Mobile

Property Owner: David Orvick, Orvick Management Group

Public Notification: A ten (10) day advanced notification for the hearing was mailed to property owners within 300 feet of the project.

Location: 201 4th Avenue, Redwood City, CA 94083

APN: 060-083-410

Size: 13,500 sq. ft.

Existing Zoning: R-3/S-5 (Multi-Family Residential/1,500 sq. ft. minimum lot area per dwelling unit)

General Plan Designation: Medium High Density Residential (8.8 – 17.4 dwelling units per acre)

Sphere-of-Influence: Redwood City

Existing Land Use: Multi-Family Residential Apartment Building

Flood Zone: FEMA Flood Insurance Rate Map Zone X; Panel Number: 06081C0302E; Effective Date: October 16, 2012

Environmental Evaluation: The proposed project is categorically exempt from California Environmental Quality Act (CEQA) Guidelines under Section 15301 (Class 1); Subsection (b) allows for the continued operation and minor alteration of existing facilities of both investor and publicly owned utilities that are used to provide electric power, natural gas, sewerage, or other public utility services.

Setting: The subject property is developed with a 20-unit, three-story apartment building located in North Fair Oaks District, on the northwest corner of the intersection of 4th Avenue and the Southern Pacific Railroad right-of-way. The existing roof-mounted antennas are not significantly visible from 4th Avenue and William Avenue. The parcel is surrounded by R-3 zoning which is comprised of a mix of both single-family and multiple-family residences. The original Use Permit for this facility was initially approved in 1999, and subsequent renewals were obtained in 2004 and 2010.



Chronology:

<u>Date</u>	<u>Action</u>
October 18, 1999	- Use Permit (UP) Application (PLN1999-00511) submitted for three antennas on the rooftop of an apartment building was approved. Facility was built and finalized under BLD1999-01097.
September 27, 2004	- First UP Renewal application approved for five years until September 2, 2009.
February 5, 2010	- Second UP Renewal application approved; renewal extended by 10-years until Jan 7, 2020.
July 26, 2019	- Third UP Renewal application received but was not approved.
January 16, 2024	- Fourth UP Renewal application received with amendment to increase the number of antennas from three to six.
April 15, 2024	- Subject application deemed complete.
June 20, 2024	- Project scheduled for ZHO Hearing.

**DISCUSSION**

A. KEY ISSUES

1. Compliance with Conditions of the Last Approval

All of the Use Permit conditions from the approved 2010 renewal are assessed below with regard to compliance and if the conditions should be either retained or revised.

Current Planning Section

- a. **Condition 1:** This Use Permit shall be valid for 10 years until **July 8, 2034**. The applicant shall file for a renewal of this permit six months prior to expiration with the County Planning Department, by submitting the applicable application forms and paying the applicable fees, if continuation of this use is desired. Any modifications to this facility will require a Use Permit amendment. If an amendment is requested, the applicant shall submit the necessary documents and fees for consideration at a public hearing.

Compliance with condition? Yes, the applicant has submitted a Use Permit renewal and amendment to increase the number of roof top-mounted antennas from three to six with this current application.

Recommend to retain condition? Yes, but modified as follows:

**Recommended Modified Condition 1:** This approval applies to the proposal, documents, and plans described in this report and submitted to and approved by the Zoning Hearing Officer on **June 20, 2024**. Any modifications beyond that which were approved by the Zoning Hearing Officer will be subject to review and approval of the Director of Planning and Building and may require review at a public hearing.

- b. **Condition 2:** This approval applies only to the proposal, documents and plans described in this report and submitted to and approved by the Zoning Hearing Officer. Minor revisions or modifications to the project may be made subject to the review and approval of the Director of Planning and Building.

Compliance with condition? Yes.

Recommend to retain condition? Yes. This condition remains relevant in order to ensure that the site continues to operate as described and conditioned under this approval.

- c. **Condition 3:** The antennas and equipment cabinets shall be maintained the originally approved and painted color. Any proposal to change the color shall be reviewed and approved by the Director of Planning and Building prior to painting. Any new color proposed should be one that best blends with the surrounding environment.

Compliance with condition? Yes.

Recommend to retain condition? Yes. This condition remains relevant in order to ensure that the site continues to operate as described and conditioned under this approval. However, the condition was modified to change the title of the Planning Director to “Director of Planning and Building” and propose to match the color of the new FRP screening to match the color of the building. The existing radome was painted in white color. However, the new FRP screening shall match the existing color of the building.

**Recommended Modified Condition 3:** The antennas and equipment cabinets shall be maintained the originally approved and painted in color to match the existing building. Any proposal to change the color shall be reviewed and approved by the Director of Planning and Building Department prior to painting. Any new color proposed should be one that best blends with the surrounding environment.

- d. **Condition 4:** This installation shall be removed in its entirety at that time when this technology becomes obsolete, or this facility is no longer needed.

Compliance with condition? Yes.

Recommend to retain condition? Yes. This condition remains relevant in the event the use was no longer conducted at this location or should the technology become obsolete.

- e. **Condition 5:** The applicant shall not enter into a contract with the landowner or lessee that reserves for one company exclusive use of structures on this site for telecommunications facilities.

Compliance with condition? Yes.

Recommend to retain condition? Yes. In order to ensure that this site remains open for co-location opportunities for other carriers this condition remains necessary.

- f. **Condition 6:** A 6-foot-tall property fence shall be maintained to screen all existing or proposed ground mounted equipment units.

**Recommended new condition:** The above new condition is added to make sure that the ground mounted equipment cabinets are always screened from the public right-of-way.

## 2. Compliance with Use Permit Findings

In order to approve the Use Permit renewal and amendment, the following Use Permit findings are necessary:

- a. *That the establishment, maintenance and/or conducting of the proposed use will not, under the circumstances of this particular case, be detrimental to the public welfare or injurious to property or improvements in said neighborhood.*

Staff has determined that the continued impacts for this project are negligible as the project has been designed to match the building and,

therefore, the project would have a minimum visual impact. The applicant has also submitted a radio frequency analysis report prepared by EBI Consulting, dated December 21, 2023. The report concludes that the cell facility would comply with the Federal Communications Commission (FCC)'s current prevailing standards for limiting human exposure to RF energy. As this is an unmanned communication facility that is regularly maintained, the modification and continued operation of the facility would not create additional traffic, noise, or intensity of use of the property.

Staff has also reviewed the project file, reviewed previous conditions of approval, code violation cases, Accela records for SWNs and finds no letters in the project file concerning non-compliance of the Cell facility or issues from neighboring parcels in the vicinity.

- b. *That the approval of this cellular telecommunication addition is necessary for the public health, safety, convenience, or welfare of the community.*

The facility use is to support personal telecommunication services. The FCC has established the desirability and need for mobile and wireless telephone service to facilitate communication between mobile units and the existing wire-dependent telephone system. The wireless system can handle a great quantity of calls in a more efficient and flexible manner than existing technology and, therefore, is a benefit to both public and private users. The facility is considered necessary for public health, safety, convenience and welfare.

### 3. Compliance with the Wireless Telecommunication Facility Ordinance

The effective date of the San Mateo County Wireless Telecommunication Facilities (WTF) Ordinance is January 9, 2009. Use Permit renewals for existing facilities constructed prior to the effective date of the Ordinance (which this facility was) are subject to the provisions of Section 6512 through 6512.5. The applicable sections are discussed below.

#### a. Development and Design Standards

Section 6512.2 of the WTF Ordinance discusses location, minimizing visual impacts, maximum height, and future co-location of wireless facilities. The existing T-Mobile facility is located on the roof of an existing apartment building and is surrounded by developed residential parcels. To minimize visual impact, the panel antennas modified facility would be completely screened by an FRB cover that would be painted to match the existing building color. The current height of the cell facility is 37 feet 6 inches, and the height of the new antennas would be lowered

to 36 feet 1 inch (1 feet 5 inches lower than existing). T-Mobile is currently the only cellular service provider located on this site. Based on the Radio Frequency (RF) report submitted as part of this renewal and amendment application dated January 16, 2024, maximum RF exposure for any person at the ground level is 1.82% of the FCC's general public limit. Based on predictive modeling, the worst case emitted power density may exceed the FCC's general public limit within approximately 19 feet of T-Mobile's proposed antennas at the main roof level. Modeling also indicated that the worst-case emitted power density will not exceed the FCC's occupational limit at the main roof level. Based on worst case predictive modeling, there would be no areas at ground level related to the proposed antennas that would exceed the FCC's occupational or general public exposure limits at this site. The applicant has not indicated any planned co-location or expansion of this site.

b. Performance Standards

In compliance with Sections 6512.2 and 6512.5 of the WTF Ordinance, the existing facility has maintained a valid FCC license. Staff is unaware of any other cellular carriers proposing to co-locate on or adjacent to the existing T-Mobile site and no requests to further intensify the use of this facility have been made.

B. ENVIRONMENTAL REVIEW

The proposed project is categorically exempt from California Environmental Quality Act (CEQA) under Section 15301 (Class 1); Subsection (b) allows for the continued operation and minor alteration of existing facilities of both investor and publicly owned utilities that are used to provide electric power, natural gas, sewerage, or other public utility services.

C. REVIEW BY THE NORTH FAIR OAKS COMMUNITY COUNCIL

In communication with Planning staff from 2021, County staff supporting the North Fair Oaks Community Council (NFOCC) have indicated that the NFOCC does not need to review use permit applications for facility renewal or modification, only applications for new cell facilities.

D. REVIEWING AGENCIES

Menlo Park Fire Protection District

## **ATTACHMENTS**

- A. Recommended Findings and Conditions of Approval
- B. Location Map
- C. Plans
- D. Radio Frequency- Electromagnetic Energy Compliance Report, December 21, 2023
- E. Photo Simulations
- F. Project Narrative

County of San Mateo  
Planning and Building Department

**RECOMMENDED FINDINGS AND CONDITIONS OF APPROVAL**

Project File Number: PLN1999-00511

Hearing Date: June 20, 2024

Prepared By: Sonal Aggarwal

For Adoption By: Zoning Hearing Officer

**RECOMMENDED FINDINGS**

For the Use Permit, Find:

1. That the establishment, maintenance and/or conducting of the proposed use will not, under the circumstances of this particular case, be detrimental to the public welfare or injurious to property or improvements in said neighborhood as a search of County records has shown that the site has operated in full compliance with the previous conditions of approval, is in compliance with the Federal Communications Commission (FCC)'s current prevailing standards for limiting human exposure to RF energy, and is compliant with the County's Wireless Telecommunication Facilities ordinance due to the design, location, and available opportunities for future co-locations.
2. That the approval of this cellular telecommunication addition is necessary for the public health, safety, convenience or welfare of the community as the site provides telecommunications coverage to the surrounding community, which serves as a benefit to both private and public users.

For the Environmental Review, Find:

3. That the proposed project is categorically exempt from California Environmental Quality Act (CEQA) Guidelines under Section 15301 (Class 1); Subsection (b) that allows for the continued operation and minor alteration of existing facilities of both investor and publicly owned utilities that are used to provide electric power, natural gas, sewerage, or other public utility services.



## **RECOMMENDED CONDITIONS OF APPROVAL**

### **Current Planning Section**

1. This permit shall be valid for 10 years until **July 8, 2034**. The applicant shall file for a renewal of this permit six months prior to expiration with the County Planning Department, by submitting the applicable application forms and paying the applicable fees if continuation of this use is desired. Any modifications to this facility will require a Use Permit amendment. If an amendment is requested, the applicant shall submit the necessary documents and fees for consideration at a public hearing.
2. This approval applies only to the proposal, documents and plans described in this report and submitted to and approved by the Zoning Hearing Officer. Minor revisions or modifications to the project may be made subject to the review and approval of the Director of Planning and Building.
3. The antennas and equipment cabinets shall be maintained as originally approved and painted in a color to match the existing building. Any proposal to change the color shall be reviewed and approved by the Director of Planning and Building prior to painting. Any new color proposed shall be one that best blends with the surrounding environment.
4. This installation shall be removed in its entirety at that time when this technology becomes obsolete, or this facility is no longer needed.
5. The applicant shall not enter into a contract with the landowner or lessee that reserves for one company exclusive use of structures on this site for telecommunications facilities.
6. **New Condition** - A 6-foot-tall property fence shall be maintained to screen all existing or proposed ground mounted equipment units.



**COUNTY OF SAN MATEO - PLANNING AND BUILDING DEPARTMENT**

# **ATTACHMENT B**

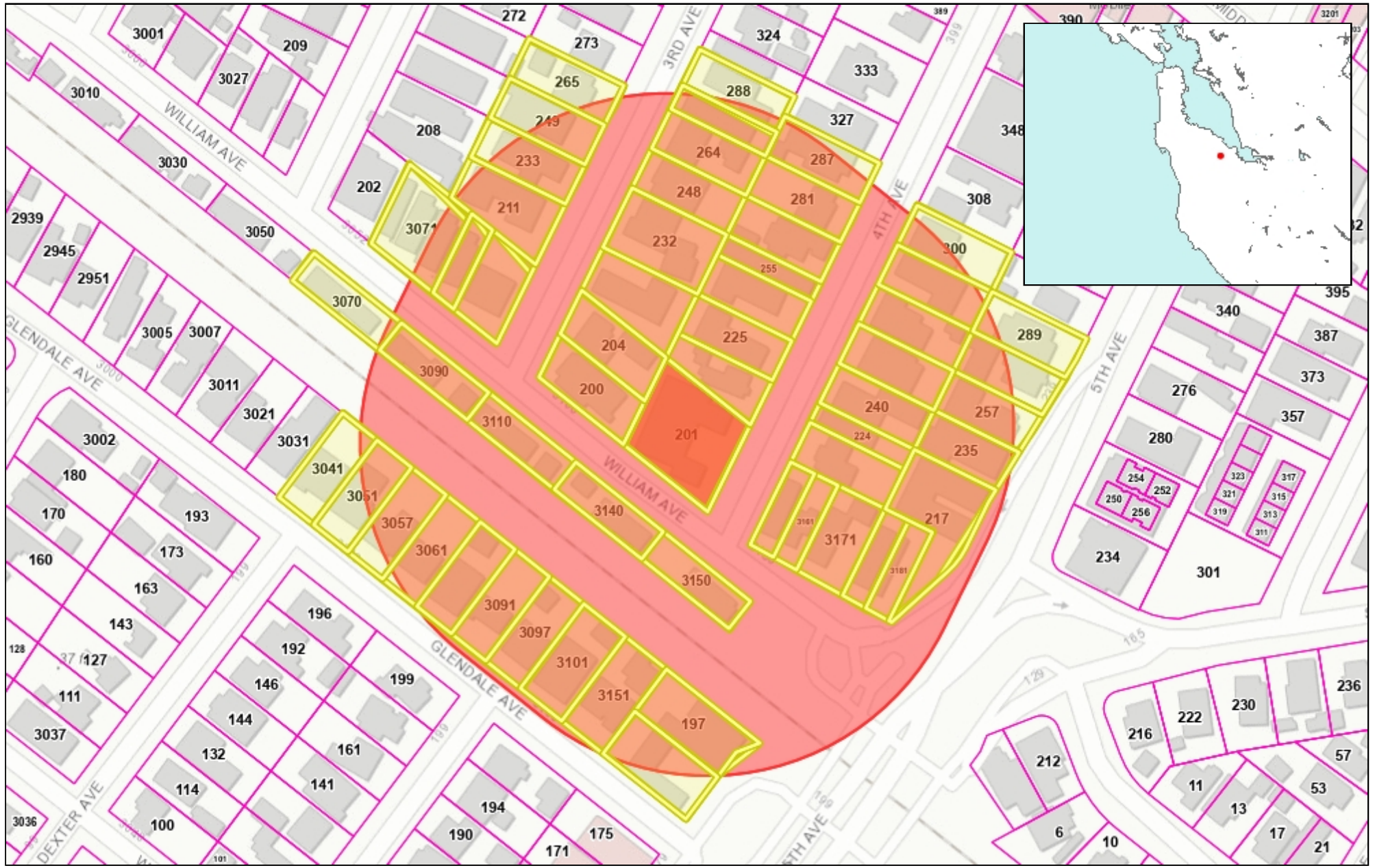

WGS\_1984\_Web\_Mercator\_Auxiliary\_Sphere  
 © Latitude Geographics Group Ltd.

1:2,257 

This map is a user generated static output from an Internet mapping site and is for reference only. Data layers that appear on this map may or may not be accurate, current, or otherwise reliable.

**THIS MAP IS NOT TO BE USED FOR NAVIGATION**



**COUNTY OF SAN MATEO - PLANNING AND BUILDING DEPARTMENT**

# **ATTACHMENT C**





**SITE NUMBER: SF03171A**  
**SITE NAME: SF171 4th AVE APT.**  
**201 4TH AVE. REDWOOD CITY, CA 94063**  
**COUNTY: SAN MATEO**  
**SITE TYPE: ROOFTOP**  
**PROJECT TYPE: ANCHOR PROJECT**

**CODE COMPLIANCE**

CONSTRUCTION WORKS AND MATERIALS MUST COMPLY WITH ALL APPLICABLE NATIONAL, STATE, AND LOCAL CODES AS ADOPTED BY LOCAL JURISDICTION, INCLUDING BUT NOT LIMITED TO:

- CALIFORNIA CODE OF REGULATIONS
- 2022 CALIFORNIA BUILDING CODE
- 2022 CALIFORNIA MECHANICAL CODE
- 2022 CALIFORNIA PLUMBING CODE
- 2022 CALIFORNIA ELECTRIC CODE
- CALIFORNIA EXISTING BUILDING CODE,
- CALIFORNIA HISTORICAL BUILDING CODE,
- CALIFORNIA RESIDENTIAL CODE
- CALIFORNIA GREEN BUILDING CODE
- 2022 EDITION OF TITLE 24 ENERGY STANDARDS
- ANY LOCAL BUILDING CODE AMENDMENTS TO THE ABOVE CITY / COUNTY ORDINANCES

**PROJECT INFORMATION**

**LANDLORD:** WALZ PROPERTIES  
**CONTACT:** 7676 ENGINEER RD  
 SAN DIEGO, CA 92111  
 PHONE: (619) 649-9000

**APPLICANT:** T-MOBILE  
**ADDRESS:** 1200 CONCORD AVE., SUITE 500  
 CONCORD, CA 94520

**LATITUDE:** 37° 28' 15.31" N (37.470919)  
**LONGITUDE:** 122° 12' 24.54" W (-122.206817)

**LAT/LONG TYPE:** NAD 83  
**GROUND ELEVATION:** +37.7' A.M.S.L.  
**APN #:** 060-083-410  
**ZONING JURISDICTION:** COUNTY OF SAN MATEO  
**PROPOSED USE:** V-B

**PROJECT MANAGER:**  
 NETWORK CONNEX  
 416 AVIATION BLVD. STE. B  
 SANTA ROSA, CA 95403  
 CONTACT: ERIC HALE  
 PHONE: (916) 805-6801  
 EMAIL: ehale@networkconnex.com

**ENGINEER:**  
 ZALZALI & ASSOCIATES INC.  
 dba  
 ALL STATES ENGINEERING & SURVEYING  
 23675 BIRTCHE DRIVE  
 LAKE FOREST, CA 92630  
 OFFICE: (949) 273-0996  
 PRINCIPAL: WISSAM ZALZALI  
 (C-71655)  
 CELL: (949) 609-9559  
 PM: KRYSSTIAN MARSHALL  
 CELL: (949) 690-7975  
 EMAIL: krystian@zalzali.com

**LOCATION MAPS**



**RFDS VERSION 9 DATE: 12/05/2022**

**CONSTRUCTION DRAWINGS**

IF USING 11"x17" PLOT, DRAWINGS WILL BE HALF SCALE

**PROJECT DESCRIPTION**

T-MOBILE WIRELESS PROPOSES TO MODIFY AN EXISTING WIRELESS COMMUNICATION SITE. THE SCOPE WILL CONSIST OF THE FOLLOWING:

**CABINET SOW**

- REMOVE EXISTING 2106 RBS EQUIPMENT CABINET
- REMOVE (3) GROUND MOUNTED RRUS-II B12 RADIOS
- REMOVE (E) STYLE 3C TMA'S AND DIPLEXERS
- REMOVE (E) RUS01 B4 AND RUS01 B2
- INSTALL (1) RBS 6160 AND (1) B160 BATTERY CABINET
- INSTALL (3) 6X24 HCS 4AWG 40M
- INSTALL (2) BB RP6651
- INSTALL (1) CSR IXRe ROUTER

**ANTENNA SOW**

- REMOVE EXISTING ANTENNA RADOME
- REMOVE (9) EXISTING TMAs
- INSTALL (1) NEW 7'X7' FRP BOX SCREEN ON ROOFTOP
- INSTALL (3) RFS APXVAALL24\_43-U-NA20 (OCTO) PANEL ANTENNAS
- INSTALL (3) ERICSSON AIR6419 B4I PANEL ANTENNAS
- INSTALL (3) 4480 B71 + B85 AT ANTENNAS
- INSTALL (3) 4460 B25 + B66 AT ANTENNAS

**POWER UPGRADE SOW**

- INSTALL NEW 200 AMP PG#E METER/MAIN
- INSTALL (1) NEW 200 AMP-RATED CONDUIT/CONDUCTORS TO EQUIPMENT AREA
- INSTALL (1) NEW 200 AMP POWER PROTECTION CABINET WITH AC SERVICE PANEL

**DRAWING INDEX**

SHEET NO:	SHEET TITLE
T-1	TITLE SHEET
GN-1	GENERAL NOTES
GN-2	GENERAL NOTES
GN-3	BATTERY INFORMATION
A-1	OVERALL SITE PLAN
A-2	EXISTING ENLARGED SITE PLAN
A-2.1	PROPOSED ENLARGED SITE PLAN
A-3	EQUIPMENT LAYOUT PLANS
A-4	ANTENNA LAYOUT PLANS
A-5	ELEVATIONS
A-6	ELEVATIONS
A-7	ELEVATIONS
A-8	ELEVATIONS
D-1	DETAILS
D-2	DETAILS
D-3	DETAILS
S-1	FRP SCREENING DETAILS
E-1	PANEL SCHEDULE & ONE-LINE DIAGRAM
E-2	ELECTRICAL DETAILS
G-1	GROUNDING SCHEMATIC, NOTES & DETAILS
G-2	GROUNDING DETAILS

**APPROVALS**

THE FOLLOWING PARTIES HEREBY APPROVE AND ACCEPT THESE DOCUMENTS & AUTHORIZE THE SUBCONTRACTOR TO PROCEED WITH THE CONSTRUCTION DESCRIBED HEREIN. ALL DOCUMENTS ARE SUBJECT TO REVIEW BY THE LOCAL BUILDING DEPARTMENT & MAY IMPOSE CHANGES OR MODIFICATIONS.

T-MOBILE RF ENGINEER: \_\_\_\_\_ DATE: \_\_\_\_\_  
 T-MOBILE OPERATIONS: \_\_\_\_\_ DATE: \_\_\_\_\_  
 SITE ACQUISITION: \_\_\_\_\_ DATE: \_\_\_\_\_  
 CONSTRUCTION MANAGER: \_\_\_\_\_ DATE: \_\_\_\_\_  
 PROPERTY OWNER: \_\_\_\_\_ DATE: \_\_\_\_\_  
 ZONING: \_\_\_\_\_ DATE: \_\_\_\_\_  
 PROJECT MANAGER: \_\_\_\_\_ DATE: \_\_\_\_\_



1200 CONCORD AVE., SUITE 500  
 CONCORD, CA 94520



416 AVIATION BLVD, SUITE B  
 SANTA ROSA, CA 95403



23675 BIRTCHE DRIVE  
 LAKE FOREST, CA 92630

**PROJECT NO:** SF03171A  
**DRAWN BY:** SS  
**CHECKED BY:** KM

REV	DATE	DESCRIPTION	BY
I	11/22/2023	REVISE FRP SCREEN	RN
O	06/14/2023	100% CD'S FOR SUBMITTAL	MG
B	12/16/2022	95% FOR APPROVAL	MG
A	12/06/2022	90% CD'S FOR REVIEW	MG



IT IS A VIOLATION OF LAW FOR ANY PERSON, UNLESS THEY ARE ACTING UNDER THE DIRECTION OF A LICENSED PROFESSIONAL ENGINEER, TO ALTER THIS DOCUMENT.

**SF03171A**  
**ATHERTON #5**  
**201 4TH AVE**  
**REDWOOD CITY, CA 94063**  
**ANCHOR PROJECT**

SHEET TITLE  
 TITLE SHEET

SHEET NUMBER  
**T-1**

**USE QR CODE FOR SITE DIRECTIONS**



**GENERAL NOTES**

THE FACILITY IS UNMANNED AND NOT FOR HUMAN HABITATION. A TECHNICIAN WILL VISIT THE SITE AS REQUIRED FOR ROUTINE MAINTENANCE. THE PROJECT WILL NOT RESULT IN ANY SIGNIFICANT DISTURBANCE OR EFFECT ON DRAINAGE; NO SANITARY SEWER SERVICE, POTABLE WATER, OR TRASH DISPOSAL IS REQUIRED AND NO COMMERCIAL SIGNAGE IS PROPOSED.



**DO NOT SCALE DRAWINGS**

SUBCONTRACTOR SHALL VERIFY ALL PLANS, EXISTING DIMENSIONS & FIELD CONDITIONS ON THE JOB SITE & SHALL IMMEDIATELY NOTIFY THE ENGINEER IN WRITING OF ANY DISCREPANCIES BEFORE PROCEEDING WITH THE WORK OR BE RESPONSIBLE FOR SAME.



**GENERAL CONSTRUCTION NOTES**

- ALL WORK SHALL CONFORM TO THE REQUIREMENTS OF THE LOCAL BUILDING CODE, THE LATEST EDITION AND ALL OTHER APPLICABLE CODES AND ORDINANCES.
- CONTRACTOR SHALL CONSTRUCT SITE IN ACCORDANCE WITH THESE DRAWINGS AND CONSTRUCTION SPECIFICATIONS 80-TII96-1 REV H. THE SPECIFICATION IS THE RULING DOCUMENT AND ANY DISCREPANCIES BETWEEN THE SPECIFICATION AND THESE DRAWINGS SHOULD BE BROUGHT TO THE ATTENTION OF THE ENGINEER PRIOR TO PROCEEDING WITH CONSTRUCTION
- CONTRACTOR SHALL VISIT THE JOB SITE AND SHALL FAMILIARIZE HIMSELF WITH ALL CONDITIONS AFFECTING THE PROPOSED WORK AND SHALL MAKE PROVISIONS AS TO THE COST THEREOF. CONTRACTOR SHALL BE RESPONSIBLE FOR FAMILIARIZING HIMSELF WITH ALL CONTRACT DOCUMENTS, FIELD CONDITIONS AND DIMENSIONS AND CONFIRMING THAT THE WORK MAY BE ACCOMPLISHED AS SHOWN PRIOR TO PROCEEDING WITH CONSTRUCTION. ANY DISCREPANCIES SHALL BE BROUGHT TO THE ATTENTION OF THE ENGINEER PRIOR TO THE COMMENCEMENT OF WORK. NO COMPENSATION WILL BE AWARDED BASED ON CLAIM OF LACK OF KNOWLEDGE OF FIELD CONDITIONS
- PLANS ARE NOT TO BE SCALED. THESE PLANS ARE INTENDED TO BE A DIAGRAMMATIC OUTLINE ONLY UNLESS OTHERWISE NOTED. THE WORK SHALL INCLUDE FURNISHING MATERIALS, EQUIPMENT AND APPURTENANCES, AND LABOR NECESSARY TO EFFECT ALL INSTALLATIONS AS INDICATED ON THE DRAWINGS. OWNER PROVIDED MATERIALS WILL INCLUDE THE FOLLOWING, UNLESS NOTED OTHERWISE:  
 A) TRANSMITTER  
 B) RF FILTER  
 C) MFTS RACK  
 D) AUXILIARY EQUIPMENT IN MFTS RACK  
 E) PUMP ASSEMBLY  
 F) HEAT EXCHANGER  
 G) HOSE AND HOSE MANIFOLDS (ANY COPPER OR STEEL SECTIONS PROVIDE BY CONTRACTOR)  
 H) UHF ANTENNA AND MOUNTING BRACKETS, GPS ANTENNAS AND KU ANTENNAS  
 I) UHF COAX AND HANGERS  
 K) 480-208 & 208-400 ELECTRICAL TRANSFORMERS (RE: E-2 FOR SPECIALIZED TRANSFORMERS PROVIDED BY CONTRACTOR)  
 L) AUTOMATIC TRANSFER SWITCH AND GENERATOR  
 M) EQUIPMENT SHELTER (SHELTERS FURNISHED IN FACTORY W/ HVAC EQUIPMENT AND ELECTRICAL DISTRIBUTION PANEL)  
 N) INTEGRATED LOAD CENTER
- DIMENSIONS SHOWN ARE TO FINISH SURFACES UNLESS OTHERWISE NOTED. SPACING BETWEEN EQUIPMENT IS REQUIRED CLEARANCE. THEREFORE, IT IS CRITICAL TO FIELD VERIFY DIMENSIONS, SHOULD THERE BE ANY QUESTIONS REGARDING THE CONTRACT DOCUMENTS, EXISTING CONDITIONS AND/OR DESIGN INTENT, THE CONTRACTOR SHALL BE RESPONSIBLE FOR OBTAINING THE WORK.
- DETAILS ARE INTENDED TO SHOW DESIGN INTENT. MODIFICATIONS MAY BE REQUIRED TO SUIT JOB DIMENSIONS OR CONDITIONS, AND SUCH MODIFICATIONS SHALL BE INCLUDED AS PART OF THE WORK.
- CONTRACTOR SHALL RECEIVE CLARIFICATION IN WRITING, AND SHALL RECEIVE IN WRITING AUTHORIZATION TO PROCEED BEFORE STARTING WORK ON ANY ITEMS NOT CLEARLY DEFINED OR IDENTIFIED BY THE CONTRACT DOCUMENTS.
- CONTRACTOR SHALL SUPERVISE AND DIRECT THE WORK USING THE BEST CONSTRUCTION SKILLS AND ATTENTION. CONTRACTOR SHALL BE SOLELY RESPONSIBLE FOR CONSTRUCTION MEANS, METHODS, TECHNIQUES, SEQUENCES AND PROCEDURES AND FOR COORDINATING ALL PORTIONS OF THE WORK UNDER CONTRACT, UNLESS OTHERWISE NOTED.
- CONTRACTOR SHALL BE RESPONSIBLE FOR THE SAFETY OF THE WORK AREA, ADJACENT AREAS AND BUILDING OCCUPANTS THAT ARE LIKELY TO BE AFFECTED BY THE WORK UNDER THIS CONTRACT. WORK SHALL CONFORM TO ALL OSHA REQUIREMENTS.
- CONTRACTOR SHALL COORDINATE HIS WORK WITH THE SUPERINTENDENT OF BUILDINGS & GROUNDS AND SCHEDULE HIS ACTIVITIES AND WORKING HOURS IN ACCORDANCE WITH THE REQUIREMENTS.
- CONTRACTOR SHALL BE RESPONSIBLE FOR COORDINATING HIS WORK WITH THE WORK OF OTHERS AS IT MAY RELATE TO RADIO EQUIPMENT, ANTENNAS AND ANY OTHER PORTIONS OF THE WORK.
- INSTALL ALL EQUIPMENT AND MATERIALS IN ACCORDANCE WITH MANUFACTURERS RECOMMENDATIONS UNLESS SPECIFICALLY OTHERWISE INDICATED OR WHERE LOCAL CODES OR REGULATIONS TAKE PRECEDENCE.
- MAKE NECESSARY PROVISIONS TO PROTECT EXISTING SURFACES, EQUIPMENT, IMPROVEMENTS, PIPING ETC. AND IMMEDIATELY REPAIR ANY DAMAGE THAT OCCURS DURING CONSTRUCTION.
- IN DRILLING HOLES INTO CONCRETE WHETHER FOR FASTENING OR ANCHORING PURPOSES, OR PENETRATIONS THROUGH THE FLOOR FOR CONDUIT RUNS, PIPE RUNS, ETC., MUST BE CLEARLY UNDERSTOOD THAT REINFORCING STEEL SHALL NOT BE DRILLED INTO, CUT OR DAMAGED UNDER ANY CIRCUMSTANCES (UNLESS NOTED OTHERWISE). LOCATIONS OF REINFORCING STEEL ARE NOT DEFINITELY KNOWN AND THEREFORE MUST BE SEARCHED FOR BY APPROPRIATE METHODS AND EQUIPMENT.
- REPAIR ALL EXISTING WALL SURFACES DAMAGED DURING CONSTRUCTION SUCH THAT THEY MATCH AND BLEND IN WITH ADJACENT SURFACES.
- SEAL PENETRATIONS THROUGH FIRE RATED AREAS WITH U.L. LISTED AND FIRE CODE APPROVED MATERIALS.
- KEEP CONTRACT AREA CLEAN, HAZARD FREE, AND DISPOSE OF ALL DIRT, DEBRIS, AND RUBBISH. EQUIPMENT NOT SPECIFIED AS REMAINING ON THE PROPERTY OF THE OWNER SHALL BE REMOVED. LEAVE PREMISES IN CLEAN CONDITION AND FREE FROM PAINT SPOTS, DUST, OR SMUDGES OF ANY NATURE. CONTRACTOR SHALL BE RESPONSIBLE FOR MAINTAINING ALL ITEMS UNTIL COMPLETION OF CONSTRUCTION.
- MINIMUM BEND RADIUS OF ANTENNA CABLES SHALL BE IN ACCORDANCE WITH CABLE MANUFACTURERS RECOMMENDATIONS.
- ALL EXISTING INACTIVE SEWER, WATER, GAS, ELECTRIC AND OTHER UTILITIES, WHICH INTERFERE WITH THE EXECUTION OF THE WORK, SHALL BE REMOVED AND/OR CAPPED, PLUGGED OR OTHERWISE DISCONTINUED AT POINTS WHICH WILL NOT INTERFERE WITH THE EXECUTION OF THE WORK, SUBJECT TO APPLICABLE REGULATORY AUTHORITIES
- CONTRACTOR SHALL MINIMIZE DISTURBANCE TO EXISTING SITE DURING CONSTRUCTION. EROSION CONTROL MEASURES, IF REQUIRED DURING CONSTRUCTION SHALL BE IN CONFORMANCE WITH JURISDICTIONAL OR STATE AND LOCAL GUIDELINES FOR EROSION AND SEDIMENT CONTROL AND COORDINATED WITH LOCAL REGULATORY AUTHORITIES.
- ALL CONSTRUCTION IS TO ADHERE TO T-MOBILE'S INTEGRATED CONSTRUCTION STANDARDS UNLESS CALIFORNIA CODE IS MORE STRINGENT.
- THE INTENT OF THE PLANS AND SPECIFICATIONS IS TO PERFORM THE CONSTRUCTION IN ACCORDANCE WITH THE CALIFORNIA BUILDING STANDARDS CODE, TITLES 19 AND 24, CALIFORNIA CODE OF REGULATIONS. SHOULD ANY CONDITIONS DEVELOP NOT COVERED BY THE APPROVED PLANS AND SPECIFICATIONS WHEREIN THE FINISHED WORK WILL NOT COMPLY WITH TITLE 24, CALIFORNIA CODE OF REGULATIONS, A CHANGE ORDER DETAILING AND SPECIFYING THE REQUIRED WORK SHALL BE SUBMITTED TO AND APPROVED BY THE JURISDICTION BEFORE PROCEEDING WITH THE WORK.

**ELECTRICAL NOTES**

- ELECTRICAL CONTRACTOR SHALL SUPPLY AND INSTALL ANY/ALL ELECTRICAL WORK INDICATED. ANY/ALL CONSTRUCTION SHALL BE IN ACCORDANCE W/DRAWINGS AND ANY/ALL APPLICABLE SPECIFICATIONS. IF ANY PROBLEMS ARE ENCOUNTERED BY COMPLYING WITH THESE REQUIREMENTS, CONTRACTOR SHALL NOTIFY 'CONSTRUCTION MANAGER' AS SOON AS POSSIBLE, AFTER THE DISCOVERY OF THE PROBLEMS, AND SHALL NOT PROCEED WITH THAT PORTION OF WORK, UNTIL THE 'CONSTRUCTION MANAGER' HAS DIRECTED THE CORRECTIVE ACTIONS TO BE TAKEN.
- ELECTRICAL CONTRACTOR SHALL VISIT THE JOB SITE AND FAMILIARIZE HIMSELF WITH ANY/ALL CONDITIONS AFFECTING ELECTRICAL AND COMMUNICATION INSTALLATION AND MAKE PROVISIONS AS TO THE COST THEREOF. ALL EXISTING CONDITIONS OF ELECTRICAL EQUIP., LIGHT FIXTURES, ETC., THAT ARE PART OF THE FINAL SYSTEM, SHALL BE VERIFIED BY THE CONTRACTOR, PRIOR TO THE SUBMITTING OF HIS BID. FAILURE TO COMPLY WITH THIS PARAGRAPH WILL IN NO WAY RELIEVE CONTRACTOR OF PERFORMING ALL WORK NECESSARY FOR A COMPLETE AND WORKING SYSTEM.
- ALL WORK SHALL BE PERFORMED IN ACCORDANCE WITH THE LATEST EDITION OF THE NEC AND ALL CODES AND LOCAL ORDINANCES OF THE LOCAL POWER & TELEPHONE COMPANIES HAVING JURISDICTION AND SHALL INCLUDE BUT NOT BE LIMITED TO:  
 C - NATIONAL FIRE CODES  
 A. UL - UNDERWRITERS LABORATORIES  
 B. NEC - NATIONAL ELECTRICAL CODE  
 C. NEMA - NATIONAL ELECTRICAL MANUFACTURERS ASSOC.  
 D. OSHA - OCCUPATIONAL SAFETY AND HEALTH ACT  
 E. SBC - STANDARD BUILDING CODE
- DO NOT SCALE ELECTRICAL DRAWINGS, REFER TO SITE PLANS AND ELEVATIONS FOR EXACT LOCATIONS OF ALL EQUIPMENT, AND CONFIRM WITH 'CONSTRUCTION MANAGER' ANY SIZES AND LOCATIONS WHEN NEEDED.
- EXISTING SERVICES: CONTRACTOR SHALL NOT INTERRUPT EXISTING SERVICES WITHOUT WRITTEN PERMISSION OF THE OWNER.
- CONTRACTOR SHALL PAY FOR ANY/ALL PERMITS, FEES, INSPECTIONS AND TESTING. CONTRACTOR IS TO OBTAIN PERMITS AND APPROVED SUBMITTALS PRIOR TO THE WORK BEGINNING OR ORDERING EQUIPMENT.
- THE TERM "PROVIDE" USED IN CONSTRUCTION DOCUMENTS AND SPECIFICATIONS, INDICATES THAT THE CONTRACTOR SHALL FURNISH AND INSTALL.
- CONTRACTOR SHALL CONFIRM WITH LOCAL UTILITY COMPANY ANY/ALL REQUIREMENTS SUCH AS THE: LUG SIZE RESTRICTIONS, CONDUIT ENTRY, SIZE OF TRANSFORMERS, SCHEDULED DOWNTIME FOR THE OWNERS' CONFIRMATION, ETC... ANY/ALL CONFLICTS SHALL BE BROUGHT TO THE ATTENTION OF THE CONSTRUCTION MANAGER, PRIOR TO BEGINNING ANY WORK.
- MINIMUM WIRE SIZE SHALL BE #12 AWG, NOT INCLUDING CONTROL WIRING, UNLESS NOTED OTHERWISE. ALL CONDUCTORS SHALL BE COPPER WITH THIN INSULATION.
- OUTLET BOXES SHALL BE PRESSED STEEL IN DRY LOCATIONS, CAST ALLOY WITH THREADED HUBS IN WET/DAMP LOCATIONS AND SPECIAL ENCLOSURES FOR OTHER CLASSIFIED AREAS.
- IT IS NOT THE INTENT OF THESE PLANS TO SHOW EVERY MINOR DETAIL OF THE CONSTRUCTION. CONTRACTOR IS EXPECTED TO FURNISH AND INSTALL ALL ITEMS FOR A COMPLETE ELECTRICAL SYSTEM AND PROVIDE ALL REQUIREMENTS FOR THE EQUIPMENT TO BE PLACED IN PROPER WORKING ORDER.
- ELECTRICAL SYSTEM SHALL BE AS COMPLETELY AND EFFECTIVELY GROUNDED, AS REQUIRED BY SPECIFICATIONS, SET FORTH BY T-MOBILE.
- ALL WORK SHALL BE PERFORMED BY A LICENSED ELECTRICAL CONTRACTOR IN A FIRST CLASS, WORKMANLIKE MANNER. THE COMPLETED SYSTEM SHALL BE FULLY OPERATIVE AND SUBJECT TO REGULATORY INSPECTION AND APPROVAL BY CONSTRUCTION MANAGER.
- ALL WORK SHALL BE COORDINATED WITH OTHER TRADES TO AVOID INTERFERENCE WITH THE PROGRESS OF CONSTRUCTION.
- CONTRACTOR SHALL GUARANTEE ANY/ALL MATERIALS AND WORK FREE FROM DEFECTS FOR A PERIOD OF NOT LESS THAN ONE YEAR FROM DATE OF ACCEPTANCE.
- THE CORRECTION OF ANY DEFECTS SHALL BE COMPLETED WITHOUT ANY ADDITIONAL CHARGE AND SHALL INCLUDE THE REPLACEMENT OR THE REPAIR OF ANY OTHER PHASE OF THE INSTALLATION, WHICH MAY HAVE BEEN DAMAGED THEREIN.
- ADEQUATE AND REQUIRED LIABILITY INSURANCE SHALL BE PROVIDED FOR PROTECTION AGAINST PUBLIC LOSS AND ANY/ALL PROPERTY DAMAGE FOR THE DURATION OF WORK.
- PROVIDE AND INSTALL CONDUIT, CONDUCTORS, PULL WIRES, BOXES, COVER PLATES AND DEVICES FOR ALL OUTLETS AS INDICATED.
- DITCHING AND BACK FILL: CONTRACTOR SHALL PROVIDE FOR ALL UNDERGROUND INSTALLED CONDUIT AND/OR CABLES INCLUDING EXCAVATION AND BACKFILLING AND COMPACTION. REFER TO NOTES AND REQUIREMENTS 'EXCAVATION, AND BACKFILLING.
- MATERIALS, PRODUCTS AND EQUIPMENT, INCLUDING ALL COMPONENTS THEREOF, SHALL BE NEW AND SHALL APPEAR ON THE LIST OF U.L. APPROVED ITEMS AND SHALL MEET OR EXCEED THE REQUIREMENTS OF THE NEC, NEMA AND IECE.
- CONTRACTOR SHALL SUBMIT SHOP DRAWINGS OR MANUFACTURERS CATALOG INFORMATION OF ANY/ALL LIGHTING FIXTURES, SWITCHES AND ALL OTHER ELECTRICAL ITEMS FOR APPROVAL BY THE CONSTRUCTION MANAGER PRIOR TO INSTALLATION.
- ANY CUTTING OR PATCHING DEEMED NECESSARY FOR ELECTRICAL WORK IS THE ELECTRICAL CONTRACTORS RESPONSIBILITY AND SHALL BE INCLUDED IN THE COST FOR WORK AND PERFORMED TO THE SATISFACTION OF THE 'CONSTRUCTION MANAGER' UPON FINAL ACCEPTANCE.
- THE ELECTRICAL CONTRACTOR SHALL LABEL ALL PANELS WITH ONLY TYPEWRITTEN DIRECTORIES. ALL ELECTRICAL WIRING SHALL BE THE RESPONSIBILITY OF THE ELECTRICAL CONTRACTOR.
- DISCONNECT SWITCHES SHALL BE H.P. RATED HEAVY-DUTY, QUICK-MAKE AND QUICK-BREAK ENCLOSURES, AS REQUIRED BY EXPOSURE TYPE.
- ALL CONNECTIONS SHALL BE MADE WITH A PROTECTIVE COATING OF AN ANTI-OXIDE COMPOUND SUCH AS "NO-OXIDE A" BY DEARBORNE CHEMICAL CO. COAT ALL WIRE SURFACES BEFORE CONNECTING. EXPOSED COPPER SURFACES, INCLUDING GROUND BARS, SHALL BE TREATED - NO SUBSTITUTIONS.
- RACEWAYS: CONDUIT SHALL BE SCHEDULE 40 PVC MEETING OR EXCEEDING NEMA TC2 - 1990. CONTRACTOR SHALL PLUG AND CAP EACH END OF SPARE AND EMPTY CONDUITS AND PROVIDE TWO SEPARATE PULL STRINGS - 200 LBS TEST POLYETHYLENE CORD. ALL CONDUIT BENDS SHALL BE A MINIMUM OF 2 FT. RADIUS. RGS CONDUITS WHEN SPECIFIED, SHALL MEET UL-6 FOR GALVANIZED STEEL. ALL FITTINGS SHALL BE SUITABLE FOR USE WITH THREADED RIGID CONDUIT. COAT ALL THREADS WITH 'BRITE ZINC' OR 'GOLD GALV'.
- SUPPORT OF ALL ELECTRICAL WORK SHALL BE AS REQUIRED BY NEC.
- CONDUCTORS: CONTRACTOR SHALL USE 98% CONDUCTIVITY COPPER WITH TYPE THWN

INSULATION, 800 VOLT, COLOR CODED. USE SOLID CONDUCTORS FOR WIRE UP TO AND INCLUDING NO. 8 AWG. USE STRANDED CONDUCTORS FOR WIRE ABOVE NO. 8 AWG.

- CONNECTORS FOR POWER CONDUCTORS: CONTRACTOR SHALL USE PRESSURE TYPE INSULATED TWIST-ON CONNECTORS FOR NO. 10 AWG AND SMALLER. USE SOLDERLESS MECHANICAL TERMINAL LUGS FOR NO. 8 AWG AND LARGER.
- SERVICE: 240/120V, SINGLE PHASE, 3 WIRE CONNECTION AVAILABLE FROM UTILITY COMPANY. OWNER OR OWNERS AGENT WILL APPLY FOR POWER.
- TELEPHONE SERVICE: CONTRACTOR SHALL PROVIDE EMPTY CONDUITS WITH PULL STRINGS AS INDICATED ON DRAWINGS.
- ELECTRICAL AND TELCO RACEWAYS TO BE BURIED A MINIMUM OF 2' DEPTH.
- CONTRACTOR SHALL PLACE TWO LENGTHS OF WARNING TAPE AT A DEPTH OF 12" BELOW GROUND AND DIRECTLY ABOVE ELECTRICAL AND TELCO SERVICE CONDUITS. CAUTIONS TAPE TO READ "CAUTION BURIED ELECTRIC" OR "BURIED TELECOMM".
- ALL BOLTS SHALL BE STAINLESS STEEL

**GROUNDING NOTES**

- COMPRESSION CONNECTIONS (2), 2 AWG BARE TINNED SOLID COPPER CONDUCTORS TO GROUNDING BAR. ROUTE CONDUCTORS TO BURIED GROUNDING RING AND PROVIDE PARALLEL EXOTHERMIC WELD.
- EC SHALL USE PERMANENT MARKER TO DRAW THE LINES BETWEEN EACH SECTION AND LABEL EACH SECTION ("P", "A", "N", "I") WITH 1" HIGH LETTERS.
- ALL HARDWARE 18-8 STAINLESS STEEL, INCLUDING LOCK WASHERS, COAT ALL SURFACES WITH AN ANTI-OXIDANT COMPOUND BEFORE MATING. ALL HARDWARE SHALL BE STAINLESS STEEL 3/8 INCH DIAMETER OR LARGER.
- FOR GROUND BOND TO STEEL ONLY: INSERT A CADMIUM FLAT WASHER BETWEEN LUG AND STEEL, COAT ALL SURFACES WITH AN ANTI-OXIDANT COMPOUND BEFORE MATING.
- NUT & WASHER SHALL BE PLACED ON THE FRONT SIDE OF THE GROUNDING BAR AND BOLTED ON THE BACK SIDE.
- NUMBER OF GROUNDING BARS MAY VARY DEPENDING ON THE TYPE OF TOWER, ANTENNA LOCATION, AND CONNECTION ORIENTATION. PROVIDE AS REQUIRED.
- WHEN THE SCOPE OF WORK REQUIRES THE ADDITION OF A GROUNDING BAR TO AN EXISTING TOWER, THE SUBCONTRACTOR SHALL OBTAIN APPROVAL FROM THE TOWER OWNER PRIOR TO MOUNTING THE GROUNDING BAR TO THE TOWER.
- ALL ELECTRICAL AND GROUNDING AT THE CELL SITE SHALL COMPLY WITH THE NATIONAL ELECTRICAL CODE (NEC), NATIONAL FIRE PROTECTION ASSOCIATION (NFPA) 780 (LATEST EDITION), AND MANUFACTURER.

**ADDITIONAL NOTES:**

- ALL DETAILS ARE SHOWN IN GENERAL TERMS. ACTUAL GROUNDING INSTALLATION AND CONSTRUCTION MAY VARY DUE TO SITE SPECIFIC CONDITIONS.
- GROUND ALL ANTENNA BASES, FRAMES, CABLE RUNS, AND OTHER METALLIC COMPONENTS USING #2 GROUND WIRES AND CONNECT TO SURFACE MOUNTED GROUND BUS BARS AS SHOWN. FOLLOW ANTENNA AND BTS MANUFACTURER'S PRACTICES FOR GROUNDING REQUIREMENTS. GROUND COAX SHIELD AT BOTH ENDS USING MANUFACTURERS PRACTICES. ALL UNDERGROUND WATER PIPES, METAL CONDUITS AND GROUNDS THAT ARE A PART OF THIS SYSTEM SHALL BE BONDED TOGETHER.
- ALL GROUND CONNECTIONS SHALL BE #2 AWG U.N.O. ALL WIRES SHALL BE COPPER THHN/THWN. ALL GROUND WIRE SHALL BE SOLID TIN COATED OR STRANDED GREEN INSULATED WIRE.
- CONTRACTOR TO VERIFY AND TEST GROUND TO SOURCE, 5 OHMS MAXIMUM. PROVIDE SUPPLEMENT GROUNDING RODS AS REQUIRED TO ACHIEVE SPECIFIED OHMS READING. GROUNDING AND OTHER OPTIONAL TESTING WILL BE WITNESSED BY THE T-MOBILE REPRESENTATIVE.
- NOTIFY ARCHITECT/ENGINEER IF THERE ARE ANY DIFFICULTIES INSTALLING GROUNDING SYSTEM DUE TO SITE SOIL CONDITIONS.
- BARE GROUNDING CONDUCTOR SHALL BE HARD DRAWN TINNED COPPER SIZES AS NOTED ON PLAN.
- ALL HORIZONTALLY RUN GROUNDING CONDUCTORS SHALL BE INSTALLED MINIMUM 12" BELOW GRADE/FROST-LINE IN TRENCH, U.N.O., AND BACK FILL SHALL BE COMPACTED AS REQUIRED BY ARCHITECT.
- ALL GROUND CONDUCTORS SHALL BE RUN AS STRAIGHT AND SHORT AS POSSIBLE, WITH A MINIMUM 12" BENDING RADIUS NOT LESS THAN 90 DEGREES.
- ALL SUPPORT STRUCTURES, CABLE CHANNEL WAYS OR WIRE GUIDES SHALL BE BONDED TO GROUND SYSTEM AT A POINT NEAREST THE MAIN GROUNDING BUS "MGB" (OR DIRECTLY TO GROUND-RING).
- ACCEPTABLE CONNECTIONS FOR GROUNDING SYSTEM SHALL BE:  
 a. BURNDY, HY-GRADE U.L. LISTED CONNECTORS FOR INDOOR USE OR AS APPROVED BY T-MOBILE PROJECT MANAGER.  
 b. CADWELD, EXOTHERMIC WELDS (WELDED CONNECTIONS).  
 c. TWO -(2) HOLE TINNED COPPER COMPRESSION (LONG BARREL) FITTINGS (BUS BAR CONNECTIONS).
- ALL CRIMPED CONNECTIONS SHALL HAVE EMBOSSED MANUFACTURER'S DIEMARK VISIBLE AT THE CRIMP (RESULTING FROM USE OF PROPER CRIMPING DEVICES).
- PRIOR TO ANY LUG-BUSSBAR CONNECTIONS, THE BUSSBAR SHALL BE CLEANED BY USE OF 'SCOTCH-BRITE' OR PLAIN STEEL WOOL AS TO REMOVE ALL SURFACE OXIDATION AND CONTAMINANTS. A COATING OF 'NO-OX-ID' SHALL BE APPLIED TO THE CONNECTION SURFACES.
- ALL CONNECTION HARDWARE SHALL BE TYPE 316 SS (NOT ATTRACTED TO MAGNETS).
- THE GROUND RING SHALL BE INSTALLED 24" MINIMUM BEYOND ANY BUILDING DRIP LINE.
- ELECTRICAL SERVICE EQUIPMENT GROUNDING SHALL COMPLY WITH NEC, ARTICLE 250-82 AND SHALL BOND ALL EXISTING AND NEW GROUNDING ELECTRODES. NEW GROUNDING ELECTRODE SHALL INCLUDE BUT NOT LIMITED TO GROUND RODS, GROUND RING IF SERVICE IS WITHIN THE RADIO EQUIPMENT LOCATION, BUILDING STEEL IF APPLICABLE, COLD WATER CONNECTIONS MUST BE MADE ON THE STREET SIDE OF MAIN SHUT-OFF VALVE.



PROJECT NO:	SF03171A
DRAWN BY:	SS
CHECKED BY:	KM

REV	DATE	DESCRIPTION	
I	11/22/2023	REVISE FRP SCREEN	RN
O	06/14/2023	100% CD'S FOR SUBMITTAL	MG
B	12/16/2022	95% FOR APPROVAL	MG
A	12/06/2022	90% CD'S FOR REVIEW	MG

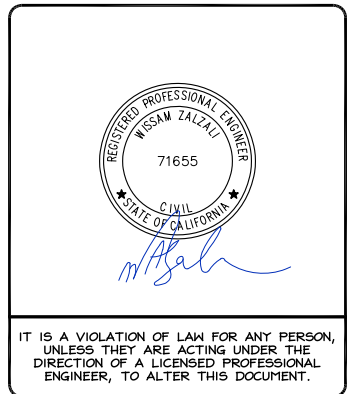

SF03171A  
 ATHONTON #5  
 201 4TH AVE  
 REDWOOD CITY, CA 94063  
 ANCHOR PROJECT

SHEET TITLE  
 GENERAL NOTES

SHEET NUMBER  
 GN-1



**SITE WORK NOTES**

- DO NOT EXCAVATE OR DISTURB BEYOND THE PROPERTY LINES OR LEASE LINES, UNLESS OTHERWISE NOTED.
- DO NOT SCALE BUILDING DIMENSIONS FROM DRAWING.
- SIZE, LOCATION AND TYPE OF ANY UNDERGROUND UTILITIES OR IMPROVEMENTS SHALL BE ACCURATELY NOTED AND PLACED ON AS-BUILT DRAWINGS BY GENERAL CONTRACTOR AND ISSUED TO ARCHITECT/ENGINEER AT COMPLETION OF PROJECT.
- ALL EXISTING UTILITIES, FACILITIES, CONDITIONS AND THEIR DIMENSIONS SHOWN ON PLANS HAVE BEEN PLOTTED FROM AVAILABLE RECORDS. THE ENGINEER AND OWNER ASSUME NO RESPONSIBILITY WHATSOEVER AS TO THE SUFFICIENCY OR ACCURACY OF THE INFORMATION SHOWN ON THE PLANS OR THE MANNER OF THEIR REMOVAL OR ADJUSTMENT. CONTRACTOR SHALL BE RESPONSIBLE FOR DETERMINING EXACT LOCATION OF ALL EXISTING UTILITIES AND FACILITIES PRIOR TO START OF CONSTRUCTION. CONTRACTOR SHALL ALSO OBTAIN FROM EACH UTILITY COMPANY DETAILED INFORMATION RELATIVE TO WORKING SCHEDULES AND METHODS OF REMOVING OR ADJUSTING EXISTING UTILITIES.
- CONTRACTOR SHALL VERIFY ALL EXISTING UTILITIES BOTH HORIZONTALLY AND VERTICALLY PRIOR TO START OF CONSTRUCTION. ANY DISCREPANCIES OR DOUBTS AS TO THE INTERPRETATION OF PLANS SHALL BE IMMEDIATELY REPORTED TO THE ARCHITECT/ENGINEER FOR RESOLUTION AND INSTRUCTION, AND NO FURTHER WORK SHALL BE PERFORMED UNTIL THE DISCREPANCY IS CHECKED AND CORRECTED BY THE ARCHITECT/ENGINEER. FAILURE TO SECURE SUCH INSTRUCTION MEANS CONTRACTOR WILL HAVE WORKED AT HIS/HER OWN RISK AND EXPENSE. CONTRACTOR SHALL CALL LOCAL DIGGER HOT LINE FOR UTILITY LOCATIONS 48 HOURS PRIOR TO START OF CONSTRUCTION.
- ALL NEW AND EXISTING UTILITY STRUCTURES ON SITE AND IN AREAS TO BE DISTURBED BY CONSTRUCTION SHALL BE ADJUSTED TO FINISH ELEVATIONS PRIOR TO FINAL INSPECTION OF WORK.
- GRADING OF THE SITE WORK AREA IS TO BE SMOOTH AND CONTINUOUS IN SLOPE AND IS TO FEATHER INTO EXISTING GRADES AT THE GRADING LIMITS.
- ALL TEMPORARY EXCAVATIONS FOR THE INSTALLATION OF FOUNDATIONS, UTILITIES, ETC., SHALL BE PROPERLY LAID BACK OR BRACED IN ACCORDANCE WITH CORRECT OCCUPATIONAL SAFETY AND HEALTH ADMINISTRATION (OSHA) REQUIREMENTS.
- STRUCTURAL FILLS SUPPORTING PAVEMENTS SHALL BE COMPACTED TO 95% OF MAXIMUM STANDARD PROCTOR DRY DENSITY.
- NEW GRADES NOT IN BUILDING AND DRIVEWAY IMPROVEMENT AREA TO BE ACHIEVED BY FILLING WITH APPROVED CLEAN FILL AND COMPACTED TO 95% OF STANDARD PROCTOR DENSITY.
- ALL FILL SHALL BE PLACED IN UNIFORM LIFTS. THE LIFTS THICKNESS SHOULD NOT EXCEED THAT WHICH CAN BE PROPERLY COMPACTED THROUGHOUT ITS ENTIRE DEPTH WITH THE EQUIPMENT AVAILABLE.
- ANY FILLS PLACED ON EXISTING SLOPES THAT ARE STEEPER THAN 10 HORIZONTAL TO 1 VERTICAL SHALL BE PROPERLY BENCHED INTO THE EXISTING SLOPE AS DIRECTED BY A GEOTECHNICAL ENGINEER.
- CONTRACTOR SHALL CLEAN ENTIRE SITE AFTER CONSTRUCTION SUCH THAT NO PAPERS, TRASH, WEEDS, BRUSH OR ANY OTHER DEPOSITS WILL REMAIN. ALL MATERIALS COLLECTED DURING CLEANING OPERATIONS SHALL BE DISPOSED OF OFF-SITE BY THE GENERAL CONTRACTOR.
- ALL TREES AND SHRUBS WHICH ARE NOT IN DIRECT CONFLICT WITH THE IMPROVEMENTS SHALL BE PROTECTED BY THE GENERAL CONTRACTOR.
- ALL SITE WORK SHALL BE CAREFULLY COORDINATED BY GENERAL CONTRACTOR WITH LOCAL UTILITY COMPANY, TELEPHONE COMPANY, AND ANY OTHER UTILITY COMPANIES HAVING JURISDICTION OVER THIS LOCATION.

**ENVIRONMENTAL NOTES**

- ALL WORK PERFORMED SHALL BE DONE IN ACCORDANCE WITH ISSUED PERMITS. THE CONTRACTOR SHALL BE RESPONSIBLE FOR PAYMENT OF FINES AND PROPER CLEAN UP FOR AREAS IN VIOLATION.
- CONTRACTOR AND/OR DEVELOPER SHALL BE RESPONSIBLE FOR CONSTRUCTION AND MAINTENANCE OF EROSION AND SEDIMENTATION CONTROLS DURING CONSTRUCTION FOR PROTECTION OF ADJACENT PROPERTIES, ROADWAYS AND WATERWAYS AND SHALL BE MAINTAINED IN PLACE THROUGH FINAL JURISDICTIONAL INSPECTION & RELEASE OF SITE.
- CONTRACTOR SHALL INSTALL/CONSTRUCT ALL NECESSARY SEDIMENT/SILT CONTROL FENCING AND PROTECTIVE MEASURES WITHIN THE LIMITS OF SITE DISTURBANCE PRIOR TO CONSTRUCTION.
- NO SEDIMENT SHALL BE ALLOWED TO EXIT THE PROPERTY. THE CONTRACTOR IS RESPONSIBLE FOR TAKING ADEQUATE MEASURES FOR CONTROLLING EROSION. ADDITIONAL SEDIMENT CONTROL FENCING MAY BE REQUIRED IN ANY AREAS SUBJECT TO EROSION.
- THE CONTRACTOR IS RESPONSIBLE FOR MAINTAINING POSITIVE DRAINAGE ON THE SITE AT ALL TIMES WITH SILT AND EROSION CONTROL MEASURES MAINTAINED ON THE DOWNSTREAM SIDE OF SITE DRAINAGE. ANY DAMAGE TO ADJACENT PROPERTY AS A RESULT OF EROSION WILL BE CORRECTED AT THE CONTRACTORS EXPENSE.
- CONTRACTOR SHALL BE RESPONSIBLE FOR DAILY INSPECTIONS AND ANY REPAIRS OF ALL SEDIMENT CONTROL MEASURES INCLUDING SEDIMENT REMOVAL AS NECESSARY.
- CLEARING OF VEGETATION AND TREE REMOVAL SHALL BE ONLY AS PERMITTED AND BE HELD TO A MINIMUM. ONLY TREES NECESSARY FOR CONSTRUCTION OF THE FACILITIES SHALL BE REMOVED.
- SEEDING AND MULCHING AND/OR SODDING OF THE SITE WILL BE ACCOMPLISHED AS SOON AS POSSIBLE AFTER COMPLETION OF THE PROJECT FACILITIES AFFECTING LAND DISTURBANCE.
- CONTRACTOR SHALL PROVIDE ALL EROSION AND SEDIMENTATION CONTROL MEASURES AS REQUIRED BY LOCAL, COUNTY AND STATE CODES AND ORDINANCES TO PROTECT EMBANKMENTS FROM SOIL LOSS AND TO PREVENT ACCUMULATION OF SOIL AND SILT IN STREAMS AND DRAINAGE PATHS LEAVING THE CONSTRUCTION AREA. THIS MAY INCLUDE SUCH MEASURES AS SILT FENCES, STRAW BALE SEDIMENT BARRIERS, AND CHECK DAMS.
- RIP RAP OF SIZES INDICATED SHALL CONSIST OF CLEAN, HARD, SOUND, DURABLE, UNIFORM IN QUALITY STONE FREE OF ANY DETRIMENTAL QUANTITY OF SOFT, FRIABLE, THIN, ELONGATED OR LAMINATED PIECES, DISINTEGRATED MATERIAL, ORGANIC MATTER, OIL, ALKALI, OR OTHER DELETERIOUS SUBSTANCES

**FOUNDATION, EXCAVATION AND BACKFILL NOTES**

- ALL FINAL GRADED SLOPES SHALL BE A MAXIMUM OF 3 HORIZONTAL TO 1 VERTICAL.
- ALL EXCAVATIONS PREPARED FOR PLACEMENT OF CONCRETE SHALL BE OF UNDISTURBED SOILS, SUBSTANTIALLY HORIZONTAL AND FREE FROM ANY LOOSE, UNSUITABLE MATERIAL OR FROZEN SOILS, AND WITHOUT THE PRESENCE OF POUNDING WATER. DENATERING FOR EXCESS GROUND WATER SHALL BE PROVIDED WHEN REQUIRED. COMPACTION OF SOILS UNDER CONCRETE PAD FOUNDATIONS SHALL NOT BE LESS THAN 95% OF THE MODIFIED PROCTOR MAXIMUM DRY DENSITY FOR THE SOIL IN ACCORDANCE WITH ASTM D1557.
- CONCRETE FOUNDATIONS SHALL NOT BE PLACED ON ORGANIC OR UNSUITABLE MATERIAL. IF INADEQUATE BEARING CAPACITY IS REACHED AT THE DESIGNED EXCAVATION DEPTH, THE UNSATISFACTORY SOIL SHALL BE EXCAVATED TO ITS FULL DEPTH AND EITHER BE REPLACED WITH MECHANICALLY COMPACTED GRANULAR MATERIAL OR THE EXCAVATION SHALL BE FILLED WITH CONCRETE OF THE SAME TYPE SPECIFIED FOR THE FOUNDATION. CRUSHED STONE MAY BE USED TO STABILIZE THE BOTTOM OF THE EXCAVATION. ANY STONE SUB BASE MATERIAL, IF USED, SHALL NOT SUBSTITUTE FOR REQUIRED THICKNESS OF CONCRETE.
- ALL EXCAVATIONS SHALL BE CLEAN OF UNSUITABLE MATERIAL SUCH AS VEGETATION, TRASH, DEBRIS, AND SO FORTH PRIOR TO BACK FILLING. BACK FILL SHALL CONSIST OF APPROVED MATERIALS SUCH AS EARTH, LOAM, SANDY CLAY, SAND AND GRAVEL, OR SOFT SHALE, FREE FROM CLOUDS OR LARGE STONES OVER 2 1/2" MAX DIMENSIONS. ALL BACK FILL SHALL BE PLACED IN COMPACTED LAYERS.
- ALL FILL MATERIALS AND FOUNDATION BACK FILL SHALL BE PLACED IN MAXIMUM 6" THICK LIFTS BEFORE COMPACTION. EACH LIFT SHALL BE WETTED IF REQUIRED AND COMPACTED TO NOT LESS THAN 95% OF THE MODIFIED PROCTOR MAXIMUM DRY DENSITY FOR SOIL IN ACCORDANCE WITH ASTM D1557.
- NEWLY PLACED CONCRETE FOUNDATIONS SHALL CURE A MINIMUM OF 72 HRS PRIOR TO BACK FILLING.
- FINISHED GRADING SHALL BE SLOPED TO PROVIDE POSITIVE DRAINAGE AND PREVENT STANDING WATER. THE FINAL (FINISH) ELEVATION OF SLAB FOUNDATIONS SHALL SLOPE AWAY IN ALL DIRECTIONS FROM THE CENTER. FINISH GRADE OF CONCRETE PADS SHALL BE A MAXIMUM OF 4 INCHES ABOVE FINAL FINISH GRADE ELEVATIONS. PROVIDE SURFACE FILL GRAVEL TO ESTABLISH SPECIFIED ELEVATIONS WHERE REQUIRED.
- NEWLY GRADED SURFACE AREAS TO RECEIVE GRAVEL SHALL BE COVERED WITH GEOTEXTILE FABRIC TYPE: TYPAR-3401 AS MANUFACTURED BY "CONSTRUCTION MATERIAL 1-800-239-3841" OR AN APPROVED EQUIVALENT, SHOWN ON PLANS. THE GEOTEXTILE FABRIC SHALL BE BLACK IN COLOR TO CONTROL THE RECURRENCE OF VEGETATIVE GROWTH AND EXTEND TO WITHIN 1 FOOT OUTSIDE THE SITE FENCING OR ELECTRICAL GROUNDING SYSTEM PERIMETER WHICH EVER IS GREATER. ALL FABRIC SHALL BE COVERED WITH A MINIMUM OF 4" DEEP COMPACTED STONE OR GRAVEL AS SPECIFIED. I.E. FDOT TYPE No. 57 FOR FENCED COMPOUND; FDOT TYPE No. 67 FOR ACCESS DRIVE AREA.
- IN ALL AREAS TO RECEIVE FILL, REMOVE ALL VEGETATION, TOPSOIL, DEBRIS, WET AND UNSATISFACTORY SOIL MATERIALS, OBSTRUCTIONS, AND DELETERIOUS MATERIALS FROM GROUND SURFACE. PLOW STRIP OR BREAK UP SLOPED SURFACES STEEPER THAN 1 VERTICAL TO 4 HORIZONTAL SUCH THAT FILL MATERIAL WILL BIND WITH EXISTING/PREPARED SOIL SURFACE.
- WHEN SUB GRADE OR PREPARED GROUND SURFACE HAS A DENSITY LESS THAN THAT REQUIRED FOR THE FILL MATERIAL, SCARIFY THE GROUND SURFACE TO DEPTH REQUIRED, PULVERIZE, MOISTURE-CONDITION AND/OR AERATE THE SOILS AND RECOMPACT TO THE REQUIRED DENSITY PRIOR TO PLACEMENT OF FILLS.
- IN AREAS WHICH EXISTING GRAVEL SURFACING IS REMOVED OR DISTURBED DURING CONSTRUCTION OPERATIONS, REPLACE GRAVEL SURFACING TO MATCH ADJACENT GRAVEL SURFACING AND RESTORED TO THE SAME THICKNESS AND COMPACTION AS SPECIFIED. ALL RESTORED GRAVEL SURFACING SHALL BE FREE FROM CORRUGATIONS AND WAVES.
- EXISTING GRAVEL SURFACING MAY BE EXCAVATED SEPARATELY AND REUSED WITH THE CONDITION THAT ANY UNFAVORABLE AMOUNTS OF ORGANIC MATTER, OR OTHER DELETERIOUS MATERIALS ARE REMOVED PRIOR TO REUSE. FURNISH ANY ADDITIONAL GRAVEL RESURFACING MATERIAL AS NEEDED TO PROVIDE A FULL DEPTH COMPACTED SURFACE THROUGHOUT SITE.
- GRAVEL SUB SURFACE SHALL BE PREPARED TO REQUIRED COMPACTION AND SUB GRADE ELEVATIONS BEFORE GRAVEL SURFACING IS PLACED AND/OR RESTORED. ANY LOOSE OR DISTURBED MATERIALS SHALL BE THOROUGHLY COMPACTED AND ANY DEPRESSIONS IN THE SUB GRADE SHALL BE FILLED AND COMPACTED WITH APPROVED SELECTED MATERIAL. GRAVEL SURFACING MATERIAL SHALL NOT BE USED FOR FILLING DEPRESSIONS IN THE SUB GRADE.
- PROTECT EXISTING GRAVEL SURFACING AND SUB GRADE IN AREAS WHERE EQUIPMENT LOADS WILL OPERATE. USE PLANKING 'MATTES' OR OTHER SUITABLE PROTECTION DESIGNED TO SPREAD EQUIPMENT LOADS AS MAY BE NECESSARY. REPAIR ANY DAMAGE TO EXISTING GRAVEL SURFACING OR SUB GRADE WHERE SUCH DAMAGE IS DUE TO THE CONTRACTORS OPERATIONS.
- DAMAGE TO EXISTING STRUCTURES AND/OR UTILITIES RESULTING FROM CONTRACTORS NEGLIGENCE SHALL BE REPAIRED AND/ OR REPLACED TO THE OWNERS SATISFACTION AT NO ADDITIONAL COST TO THE CONTRACT.
- ALL SUITABLE BORROW MATERIAL FOR BACK FILL OF THE SITE SHALL BE INCLUDED IN THE BID. EXCESS TOPSOIL AND UNSUITABLE MATERIAL SHALL BE DISPOSED OF OFF SITE AT LOCATIONS APPROVED BY GOVERNING AGENCIES AT NO ADDITIONAL COST TO THE CONTRACT.

**STRUCTURAL STEEL NOTES**

- ALL STEEL WORK SHALL BE IN ACCORDANCE WITH THE LATEST EDITION OF THE AISC MANUAL OF STEEL CONSTRUCTION. STEEL SECTIONS SHALL BE IN ACCORDANCE WITH ASTM AS INDICATED BELOW:  
 W SHAPES: ASTM A992, 50 KSI  
 ANGLES, BARS CHANNELS: ASTM A36, 36 KSI  
 HSS SECTIONS: ASTM 500, 46 KSI  
 PIPE SECTIONS: ASTM A53-E, 35 KSI
- ALL EXTERIOR EXPOSED STEEL AND HARDWARE SHALL BE HOT DIPPED GALVANIZED.
- ALL WELDING SHALL BE PERFORMED USING E70XX ELECTRODES AND WELDING SHALL CONFORM TO AISC WHERE FILLET WELD SIZES ARE NOT SHOWN, PROVIDE THE MINIMUM SIZE PER TABLE J2.4 IN THE AISC "MANUAL OF STEEL CONSTRUCTION". PAINTED SURFACES SHALL BE TOUCHED UP.
- BOLTED CONNECTIONS SHALL BE ASTM A325 BEARING TYPE 3/4"Ø CONNECTIONS AND SHALL HAVE MINIMUM OF TWO BOLTS UNLESS NOTED OTHERWISE.
- NON-STRUCTURAL CONNECTIONS FOR STEEL GRATING MAY USE 5/8" DIA. ASTM A307 BOLTS UNLESS NOTED OTHERWISE.
- FIELD MODIFICATIONS ARE TO BE COATED WITH ZINC ENRICHED PAINT.

**CONCRETE MASONRY NOTES**

- CONCRETE MASONRY UNITS SHALL BE MEDIUM WEIGHT UNITS CONFORMING TO ASTM C90, GRADE N-1, (F<sub>m</sub>=1,500 PS). MEDIUM WEIGHT (115 PCF).
- MORTAR SHALL BE TYPE "S" (MINIMUM 1,800 PSI AT 28 DAYS).
- GROUT SHALL HAVE A MINIMUM COMPRESSIVE STRENGTH OF 2,000 PSI AT 28 DAYS.
- ALL CELLS CONTAINING REINFORCING STEEL OR EMBEDDED ITEMS AND ALL CELLS IN RETAINING WALLS AND WALLS BELOW GRADE SHALL BE SOLID GROUTED.
- ALL HORIZONTAL REINFORCEMENT SHALL BE PLACED IN BOND BEAM OR LINTEL BEAM UNITS.
- WHEN GROUTING IS STOPPED FOR ONE HOUR OR LONGER, HORIZONTAL CONSTRUCTION JOINTS SHALL BE FORMED BY STOPPING THE GROUT FOUR 1-1/2" BELOW TOP OF THE UPPERMOST UNIT.
- ALL BOND BEAM BLOCK SHALL BE "DEEP CUT" UNITS.
- PROVIDE INSPECTION AND CLEAN-OUT HOLES AT BASE OF VERTICAL CELLS HAVING GROUT LIFTS IN EXCESS OF 4'-0" OF HEIGHT.
- ALL GROUT SHALL BE CONSOLIDATED WITH A MECHANICAL VIBRATOR.
- CEMENT SHALL BE AS SPECIFIED FOR CONCRETE.
- REINFORCING BARS - SEE NOTES UNDER "REINFORCING STEEL" FOR REQUIREMENTS.
- PROVIDE ONE BAR DIAMETER (A MINIMUM OF 1/2") GROUT BETWEEN MAIN REINFORCING AND MASONRY UNITS.
- LOW LIFT CONSTRUCTION, MAXIMUM GROUT POUR HEIGHT IS 4 FEET.
- HIGH LIFT GROUTED CONSTRUCTION MAY BE USED IN CONFORMANCE WITH PROJECT SPECIFICATIONS AND SECTION 2104A.5.1.2.3 OF U.B.C.
- ALL CELLS IN CONCRETE BLOCKS SHALL BE FILLED SOLID WITH GROUT, EXCEPT AS NOTED IN THE DRAWINGS OR SPECIFICATIONS.
- CELLS SHALL BE IN VERTICAL ALIGNMENT, DOWELS IN FOOTINGS SHALL BE SET TO ALIGN WITH CORES CONTAINING REINFORCING STEEL.
- REFER TO ARCHITECTURAL DRAWINGS FOR SURFACE AND HEIGHT OF UNITS, LAYING PATTERN AND JOINT TYPE.
- SAND SHALL BE CLEAN, SHARP AND WELL GRADED, FREE FROM INJURIOUS AMOUNTS OF DUST LUMPS, SHALE, ALKAU OR ORGANIC MATERIAL.
- BRICK SHALL CONFORM TO ASTM C-62 AND SHALL BE GRADE 1M OR BETTER.
- CONTRACTOR TO PROVIDE STRUCTURAL INSPECTIONS AND/OR OBSERVATIONS AS REQUIRED BY CBC.

**STRUCTURAL CONCRETE NOTES**

- ALL CONCRETE WORK SHALL BE IN ACCORDANCE WITH THE ACI 301-16, ACI 318-14 AND THE SPECIFICATION FOR CAST-IN-PLACE CONCRETE.
- ALL CONCRETE SHALL HAVE A MINIMUM COMPRESSIVE STRENGTH f<sub>c</sub>'=2,500 PSI AT 28 DAYS UNLESS NOTED OTHERWISE.
- REINFORCING STEEL SHALL CONFORM TO ASTM A 615, GRADE 60, DEFORMED UNLESS NOTED OTHERWISE. WELDED WIRE FABRIC SHALL CONFORM TO ASTM A 185 WELDED STEEL WIRE FABRIC UNLESS NOTED OTHERWISE. SPLICES CLASS "B" AND ALL HOOKS SHALL BE STANDARD UNLESS NOTED OTHERWISE.
- THE FOLLOWING MINIMUM CONCRETE COVER SHALL BE PROVIDED FOR REINFORCING STEEL UNLESS SHOWN OTHERWISE ON DRAWINGS:  
 CONCRETE CAST AGAINST EARTH.....3 IN.  
 CONCRETE EXPOSED TO EARTH OR WEATHER:  
 #6 AND LARGER.....2 IN.  
 #5 AND SMALLER # WWF .....1-1/2 IN.  
 CONCRETE NOT EXPOSED TO EARTH OR WEATHER OR NOT CAST AGAINST THE GROUND:  
 SLAB AND WALL .....3/4 IN.  
 BEAMS AND COLUMNS.....1-1/2 IN.
- A 3/4" CHAMFER SHALL BE PROVIDED AT ALL EXPOSED EDGES OF CONCRETE U.N.O. IN ACCORDANCE WITH ACI 301 SECTION 4.2.4.
- HOLES TO RECEIVE EXPANSION/WEDGE ANCHORS SHALL BE 1/8" LARGER IN DIAMETER THAN THE ANCHOR BOLT, DOWEL OR ROD AND SHALL CONFORM TO MANUFACTURER'S RECOMMENDATION FOR EMBEDMENT DEPTH OR AS SHOWN ON THE DRAWINGS. LOCATE AND AVOID CUTTING EXISTING REBAR WHEN DRILLING HOLES IN ELEVATED CONCRETE SLABS.
- USE AND INSTALLATION OF CONCRETE EXPANSION/WEDGE ANCHOR, SHALL BE PER ICC ER# & MANUFACTURER'S WRITTEN RECOMMENDED PROCEDURES.

**FIRE DEPARTMENT NOTES**

- THE T-MOBILE PROJECT MANAGER'S DIRECTION, THE CONTRACTOR SHALL PROVIDE "HILTI" HIGH PERFORMANCE INTUMESCENT FIRE STOP SEALANT #FS-ONE (OR APPROVED EQUIVALENT) AT ALL FIRE RATED PENETRATION INSTALLED PER MANUFACTURER'S LATEST INSTALLATION SPECIFICATION.
- ALL PENETRATIONS THROUGH FIRE RATED ASSEMBLIES SHALL BE CONSTRUCTED SO AS TO MAINTAIN AN EQUAL OR GREATER FIRE RATING.
- BUILDINGS UNDERGOING CONSTRUCTION, ALTERATION OR DEMOLITION SHALL BE IN ACCORDANCE WITH CFC ARTICLE 87. [CFC 8701]
- ADDRESS SHALL BE PROVIDED FOR ALL NEW AND EXISTING BUILDINGS IN A POSITION AS TO BE PLAINLY SEEN VISIBLE AND LEGIBLE FROM THE STREET OR ROAD FRONTING THE PROPERTY [CFC 901.4.4, FHPS POLICY P-00-6]
- DECORATIVE MATERIALS SHALL BE MAINTAINED IN A FLAME-RETARDANT CONDITION. [CALIF. CODE OF REGS., TITLE 19, 3.08, 3.21, CEC 2501.5]
- ALL VALVES CONTROLLING THE WATER SUPPLY FOR AUTOMATIC SPRINKLER SYSTEM AND WATER-FLOW SWITCHES ON AL SPRINKLER SYSTEMS SHALL BE ELECTRICALLY MONITORED WHERE THE NUMBER OF SPRINKLERS IS A 100 OR MORE. [CBC 904.3.1, CFC 1003.3.1]
- INSTALLATION OF FIRE ALARM SYSTEMS SHALL BE IN ACCORDANCE WITH CFC 1007.
- AT LEAST ONE FIRE EXTINGUISHER WITH A MINIMUM RATING OF 2A-10BC SHALL BE PROVIDED WITHIN 75 FT. MAXIMUM TRAVEL DISTANCE FOR EACH 6,000 SQ. FT. OR PORTION THEREOF ON EACH FLOOR [CFC 1002, UFC STANDARD 10-1, CALIF. CODE OF REGS., TITLE 19, 3.29]
- CONTRACTOR SHALL VERIFY IN FIELD THE EXISTENCE OR INSTALLATION OF A FIRE EXTINGUISHER WITH A MINIMUM RATING OF 2A-10BC, WITH A CHARGE STATUS ACCEPTABLE TO THE LOCAL FIRE AUTHORITY HAVING JURISDICTION.
- COMPLETE PLANS AND SPECIFICATIONS FOR ALARM SYSTEMS: FIRE-EXTINGUISHING SYSTEMS, INCLUDING AUTOMATIC SPRINKLERS AND OTHER FIRE-PROTECTION SYSTEMS SHALL BE SUBMITTED TO FIRE AND LIFE SAFETY FOR REVIEW AND APPROVAL TO INSTALLATION. [CFC 100.3]

**T-Mobile**  
 1200 CONCORD AVE., SUITE 500  
 CONCORD, CA 94520

**NETWORK CONNEX**  
 416 AVIATION BLVD, SUITE B  
 SANTA ROSA, CA 95403

**ALLSTATES**  
 ENGINEERING & SURVEYING  
 23675 BIRTCHE DRIVE  
 LAKE FOREST, CA 92630

PROJECT NO:	SF03171A
DRAWN BY:	SS
CHECKED BY:	KM

REV	DATE	DESCRIPTION	
I	11/22/2023	REVISE FRP SCREEN	RN
O	06/14/2023	100% CD'S FOR SUBMITTAL	MG
B	12/16/2022	95% FOR APPROVAL	MG
A	12/06/2022	90% CD'S FOR REVIEW	MG

REGISTERED PROFESSIONAL ENGINEER  
 WISSAM ZALZALI  
 71655  
 CIVIL  
 STATE OF CALIFORNIA  
  
 IT IS A VIOLATION OF LAW FOR ANY PERSON, UNLESS THEY ARE ACTING UNDER THE DIRECTION OF A LICENSED PROFESSIONAL ENGINEER, TO ALTER THIS DOCUMENT.

SF03171A  
 ATHONTON #5  
 201 4TH AVE  
 REDWOOD CITY, CA 94063  
 ANCHOR PROJECT

SHEET TITLE  
 GENERAL NOTES

SHEET NUMBER  
**GN-2**



**NSB 100FT Silver Battery™**  
Specifically designed for semi stable mains



Designed for high power and superior cyclic capability - built to be reliable, even when the power mains are not.

- High cycle capability, high energy density
- Fast recharge performance
- 10 year float life at 25°C (77°F)
- EUROBAT design life definition: Long Life (12+ years)
- State-of-the-art automated manufacturing ensures consistency and reliability
- Advanced 3 stage terminal design to ensure leak-free operation
  - Female MB brass terminals provide maximum performance
- Operating temperature range: -40°C to +65°C (-40°F to 149°F)
- High modulus Polyphenylene Oxide (PPO) plastic materials designed to withstand extended elevated operating temperatures and maintain high battery compression essential for reliable operation
  - Non-halogenated, thermally sealed plastic casing and cover
  - Flame retardant (UL 94 V0) and LOI of at least 28%
- Integral handles and front access terminals ensure ease of installation and maintenance
- Approved as non-hazardous cargo for ground, sea, and air transport
  - DOT 49CFR173.159(d), (i) and (j)

Visit our website to find out more [www.northstarbattery.com](http://www.northstarbattery.com)



**NSB 100FT Silver Battery™**  
Technical Specifications



Electrical	International Standard 20°C (68°F)	North American Standard 25°C (77°F)
8 hour capacity to 1.75 Volts/Cell	99 Ah	101 Ah
10 hour capacity to 1.80 Volts/Cell	100 Ah	101 Ah
Float Voltage	2.29 +/- 0.02	2.27 +/- 0.02
Nominal Voltage	12 V	
Impedance (1kHz)	3.4 mΩ @ 25°C (77°F)	
Conductance	1452 S	
Short Circuit Current	3,500 A	

Dimensions				
Height	287 mm (11.3 in)	Weight	34 kg (74 lbs)	
Width	108 mm (4.2 in)	Terminal	Female MB x 1.25	
Depth	395 mm (15.6 in)	Terminal Torque	8.0 Nm (7.1 in-lbs)	

Ah Capacity Ratings @ 25°C (77°F)	1	2	4	8	10
Capacity Discharge (hours)					
Capacity @ 25%/Ah	77	85	94	101	101
End of Discharge	1.70	1.75	1.75	1.75	1.80

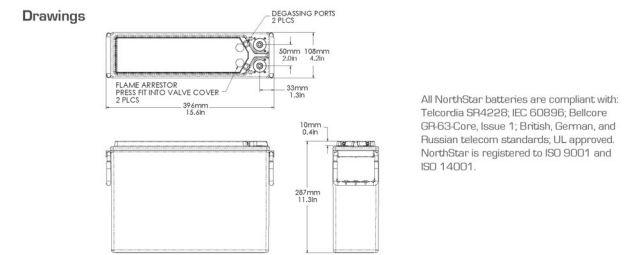

All NorthStar batteries are compliant with Telcordia SR4228, IEC 60896, Bellcore GR63-Core, Issue 1; British, German, and Russian telecom standards; UL approved. NorthStar is registered to ISO 9001 and ISO 14001.

**NorthStar in the Americas**  
NorthStar Battery Company LLC  
4000 Continental Way  
Springfield, MD, 20683  
info@northstarbattery.com  
Tel: +1 417 575 8200  
Fax: +1 417 575 8250

**NorthStar in Europe, Middle East, Africa**  
SitaTel Sweden AB  
Sjaffars Väg 6-B  
Box 71339, SE-192 07 Sollentuna,  
Stockholm, Sweden  
emea@northstarbattery.com  
Tel: +46 8 410 102 00  
Fax: +46 8 638 06 00

**NorthStar in Asia-Pacific**  
SitaTel Shanghai Co Ltd  
Building 3, 1201 Gui Gio Road  
Jin Gio Export Process Zone,  
201206 Shanghai, China  
asia@northstarbattery.com  
Tel: +86 21 5899 7610  
Fax: +86 21 3872 2201

[www.northstarbattery.com](http://www.northstarbattery.com)



**NSB 190FT HT RED**

Pure Lead - High Temp



The NSB HT RED Battery® delivers long life in unreliable grid conditions even at high temperatures.

- Pure lead electrochemistry greatly increases temp and corrosion resistance while reducing component aging
- Thin plates deliver large surface area high power density and low resistance
- Design life 15+ years at 20°C (68°F)
- Extra long life at high temp operation 40°C (104°F)
- EUROBAT design life definition: Very Long Life (12+ years)
- Advanced 3 stage terminal design to ensure leak-free operation - brass terminals provide maximum performance
- Approved as non-hazardous cargo for ground, sea and air transport DOT 49CFR173.159(d), (i) and (j)
- Fast recharging
- High cyclic performance
- Flame retardant (UL 94 V0) and LOI of at least 28%
- Shelf life of up to 24 months
- Operating temperature range -40°C to +65°C (-40°F to 149°F)
- State-of-the-art automated manufacturing ensures consistency and reliability
- High modulus Polyphenylene Oxide (PPO) plastic materials designed to withstand extended elevated operating temperatures and maintain high battery compression essential for reliable operation
- Non-halogenated thermally sealed plastic casing

Release date: 2017-03-03

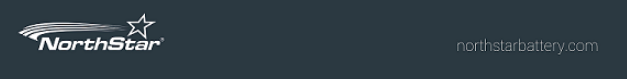

**NSB 190FT HT RED**  
Nominal Technical Specifications

Dimensions			
Height	12.6 in	Width	4.9 in
Length	22 in	Weight	132 lbs

Electrical		
Terminal		Female MB x 1.25
Terminal torque		8.0 Nm (7.1 in-lbs)
1 hr capacity to 1.70VPC @ 20/25°C (68/77°F)		140 / 145 Ah
3 hr capacity to 1.75VPC @ 20/25°C (68/77°F)		167 / 172 Ah
8 hr capacity to 1.75VPC @ 20/25°C (68/77°F)		185 / 188 Ah
10 hr capacity to 1.80VPC @ 20/25°C (68/77°F)		187 / 190 Ah
Float voltage @ 20/25°C (68/77°F)		2.28 / 2.27 VPC
Impedance (1kHz)		2.3 mΩ @ 25°C (77°F)
Conductance		2366 S
Short circuit current		6000 A
Operation temperature range		-40°C to +65°C
Nominal voltage		12 V

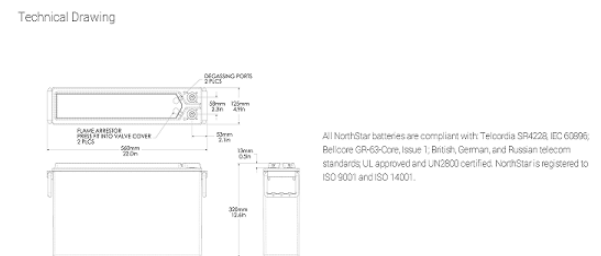

All NorthStar batteries are compliant with Telcordia SR4228, IEC 60896, Bellcore GR63-Core, Issue 1; British, German, and Russian telecom standards; UL approved and UN303 certified. NorthStar is registered to ISO 9001 and ISO 14001.

**NorthStar Americas/EMEA/AF**  
NorthStar Battery Company LLC  
4000 Continental Way  
Springfield, MD, 20683  
info@northstarbattery.com  
Tel: +1 417 575 8200  
Fax: +1 417 575 8250

**NorthStar Europe**  
SitaTel Sweden AB  
Sjaffars Väg 6-B  
Box 71339, SE-192 07 Sollentuna,  
Stockholm, Sweden  
emea@northstarbattery.com  
Tel: +46 8 410 102 00  
Fax: +46 8 638 06 00

**NorthStar Middle East, Africa**  
SitaTel Shanghai Co Ltd  
Building 3, 1201 Gui Gio Road  
Jin Gio Export Process Zone,  
201206 Shanghai, China  
asia@northstarbattery.com  
Tel: +86 21 5899 7610  
Fax: +86 21 3872 2201

**NorthStar Asia-Pacific**  
SitaTel Shanghai Co Ltd  
Building 3, 1201 Gui Gio Road  
Jin Gio Export Process Zone,  
201206 Shanghai, China  
asia@northstarbattery.com  
Tel: +86 21 5899 7610  
Fax: +86 21 3872 2201

Release date: 2017-03-03

**EXISTING BATTERIES:**  
BATTERY TYPE: NORTHSTAR NSB100FT SILVER  
NUMBER OF BTS UNITS W/ BATTERIES: 1  
NUMBER OF BATTERIES PER BTS: 4 BATTERIES (VRLA)  
WEIGHT PER BATTERY: 74 LBS

**MATERIAL:** ELECTROLYTE  
**VOLUME:** 1.20 GALLONS (13.4 LBS) / PER BATTERY  
**SITE TOTAL:** 4.80 GALLONS

**MATERIAL:** LEAD  
**VOLUME:** 37 LBS / BATTERY  
**SITE TOTAL:** 148 LBS

**MATERIAL:** LEAD OXIDE  
**VOLUME:** 14.8 LBS / PER BATTERY  
**SITE TOTAL:** 59.2 LBS

**NOTE:**  
A SEPARATE PERMIT SHALL BE REQUIRED IF COMBINED (FLOODED AND VRLA) LEAD-ACID BATTERY SYSTEM EXCEEDS 70KWH CAPACITY (CFC 608, SEE 1/-).

**NEW BATTERIES:**  
BATTERY TYPE: NORTHSTAR NSB190FT HT RED  
NUMBER OF BATTERY CABINETS: 1  
NUMBER OF BATTERIES PER CAB: 12 BATTERIES (FLOODED)  
WEIGHT PER BATTERY: 132 LBS

**MATERIAL:** ELECTROLYTE  
**VOLUME:** 2.04 GALLONS (22.44 LBS) / PER BATTERY  
**SITE TOTAL:** 24.48 GALLONS

**MATERIAL:** LEAD  
**VOLUME:** 66 LBS / BATTERY  
**SITE TOTAL:** 792 LBS

**MATERIAL:** LEAD OXIDE  
**VOLUME:** 26.4 LBS / PER BATTERY  
**SITE TOTAL:** 316.8 LBS

**NOTE:**  
A SEPARATE PERMIT SHALL BE REQUIRED IF COMBINED (FLOODED AND VRLA) LEAD-ACID BATTERY SYSTEM EXCEEDS 70KWH CAPACITY (CFC 608, SEE 1/-).

**COMBINED BATTERY SYSTEMS:**  
SYSTEM BATTERY TYPES: (4) VRLA + (12) FLOODED  
NUMBER OF CABINETS W/ CELLS: 2  
TOTAL NUMBER OF BATTERIES: 16 BATTERIES  
TOTAL BATTERY WEIGHT ON SITE: 1,880 LBS

**MATERIAL:** ELECTROLYTE  
**VOLUME:** 29.28 GALLONS  
**WEIGHT:** 322.88 LBS

**MATERIAL:** LEAD  
**SITE TOTAL:** 940 LBS

**MATERIAL:** LEAD OXIDE  
**SITE TOTAL:** 376 LBS

**NOTE:**  
A SEPARATE PERMIT SHALL BE REQUIRED IF COMBINED (FLOODED AND VRLA) LEAD-ACID BATTERY SYSTEM EXCEEDS 70KWH CAPACITY (CFC 608, SEE 1/-).

**COMBINED BATTERY DATA**

24"x36" SCALE: NTS  
11"x17" SCALE: NTS **2**

**608.1 Scope**  
Stationary storage battery systems having capacities exceeding the values shown in Table 608.1 shall comply with Sections 608.1.2 through 608.6.6, as applicable.

**NORTHSTAR NSB 190FT HT RED**

NEW RBS-6160 BATTERIES  
12 VOLTS x 190 AMP-HOURS = 2,280 VOLT-AMP-HOURS (WATT-HOURS)

2,280 WATT-HOURS / 1000 = 2.280 KILOWATT-HOURS (KWH) PER BATTERY

2.28 KWH x 12 BATTERIES = **27.36 KWH** TOTAL NEW BATTERY CABINET CAPACITY

**TABLE 608.1 BATTERY STORAGE SYSTEM THRESHOLD QTY.**

BATTERY TECHNOLOGY	CAPACITY <sup>a</sup>
Lead acid, all types	70 kWh (252 Megajoules)
Nickel cadmium (Ni-Cd)	70 kWh (252 Megajoules)
Lithium, all types	20 kWh (72 Megajoules)
Sodium, all types	20 kWh (72 Megajoules)
Flow batteries <sup>b</sup>	20 kWh (72 Megajoules)
Other battery technologies	10 kWh (36 Megajoules)

**NORTHSTAR NSB 100FT**

EXISTING ACTIVE RBS-6131 BATTERIES  
12 VOLTS x 100 AMP-HOURS = 1,200 VOLT-AMP-HOURS (WATT-HOURS)

1,200 WATT-HOURS / 1000 = 1.2 KWH (KILOWATT-HOURS) PER BATTERY

1.2 KWH x 4 BATTERIES = **4.8 KWH** TOTAL EXISTING BATTERY SYSTEM CAPACITY

- For batteries rated in amp-hours, kWh shall equal rated voltage times amp-hour rating divided by 1000.
- Shall include vanadium, zinc-bromine, polysulfide-bromide, and other flowing electrolyte type technologies.
- 70 kWh (252 Megajoules) for sodium-ion technologies

**EXISTING & NEW NORTHSTAR BATTERY SYSTEMS COMBINED CAPACITIES**

27.36 KWH TOTAL NEW BATTERY SYSTEM CAPACITY

4.8 KWH TOTAL EXISTING BATTERY SYSTEM CAPACITY

27.36 KWH (NEW SYSTEM) + 4.8 KWH (EXISTING SYSTEM) = **32.16 KWH** TOTAL COMBINED SYSTEM CAPACITY.

**32.16 KWH** < 70 KWH BATTERY SYSTEM CAPACITY REGULATORY THRESHOLD. COMBINED BATTERY SYSTEMS ARE COMPLIANT WITH CFC 608.1 (608.1.2 THROUGH 608.6.6) WHEN TABULATED TOGETHER AS ONE SYSTEM.



416 AVIATION BLVD, SUITE B  
SANTA ROSA, CA 95403



PROJECT NO: SF03171A  
DRAWN BY: SS  
CHECKED BY: KM

REV	DATE	DESCRIPTION	
I	11/22/2023	REVISE FRP SCREEN	RN
O	06/14/2023	100% CD'S FOR SUBMITTAL	MG
B	12/16/2022	95% FOR APPROVAL	MG
A	12/06/2022	90% CD'S FOR REVIEW	MG



IT IS A VIOLATION OF LAW FOR ANY PERSON, UNLESS THEY ARE ACTING UNDER THE DIRECTION OF A LICENSED PROFESSIONAL ENGINEER, TO ALTER THIS DOCUMENT.

SF03171A  
ATHERTON #5  
201 4TH AVE  
REDWOOD CITY, CA 94063  
ANCHOR PROJECT

SHEET TITLE  
BATTERY INFORMATION

SHEET NUMBER  
**GN-3**

**EXISTING BATTERIES (VRLA)**

24"x36" SCALE: NTS  
11"x17" SCALE: NTS

**4 NEW BATTERIES (FLOODED)**

24"x36" SCALE: NTS  
11"x17" SCALE: NTS

**3 BATTERY COMPLIANCE (CFC SECTION 608)**

**1**

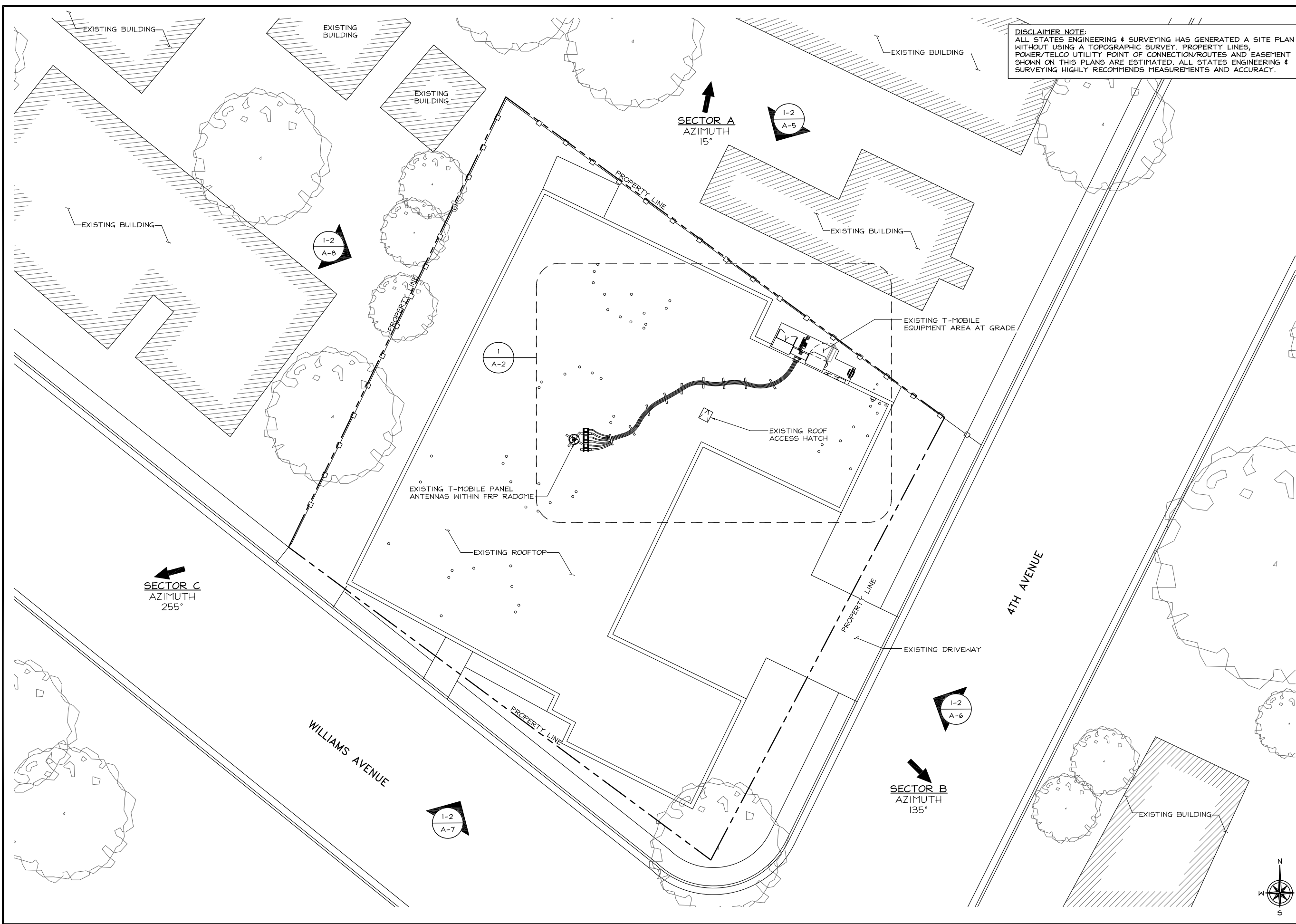

**DISCLAIMER NOTE:**  
 ALL STATES ENGINEERING & SURVEYING HAS GENERATED A SITE PLAN WITHOUT USING A TOPOGRAPHIC SURVEY. PROPERTY LINES, POWER/TELCO UTILITY POINT OF CONNECTION/ROUTES AND EASEMENT SHOWN ON THIS PLANS ARE ESTIMATED. ALL STATES ENGINEERING & SURVEYING HIGHLY RECOMMENDS MEASUREMENTS AND ACCURACY.

**T-Mobile**  
 1200 CONCORD AVE., SUITE 500  
 CONCORD, CA 94520

**NETWORK CONNEX**  
 416 AVIATION BLVD, SUITE B  
 SANTA ROSA, CA 95403

**ALLSTATES**  
 ENGINEERING & SURVEYING  
 23675 BIRTCHEER DRIVE  
 LAKE FOREST, CA 92630

PROJECT NO: SF03171A  
 DRAWN BY: SS  
 CHECKED BY: KM

REV	DATE	DESCRIPTION	
1	11/22/2023	REVISE FRP SCREEN	RN
0	06/14/2023	100% CD's FOR SUBMITTAL	MG
B	12/16/2022	95% FOR APPROVAL	MG
A	12/06/2022	90% CD'S FOR REVIEW	MG

REGISTERED PROFESSIONAL ENGINEER  
 WISSAM ZALZALI  
 71655  
 CIVIL  
 STATE OF CALIFORNIA  
*W. Zalzali*

IT IS A VIOLATION OF LAW FOR ANY PERSON, UNLESS THEY ARE ACTING UNDER THE DIRECTION OF A LICENSED PROFESSIONAL ENGINEER, TO ALTER THIS DOCUMENT.

SF03171A  
 ATHON #5  
 201 4TH AVE  
 REDWOOD CITY, CA 94063  
 ANCHOR PROJECT

SHEET TITLE  
 OVERALL SITE PLAN

SHEET NUMBER  
**A-1**



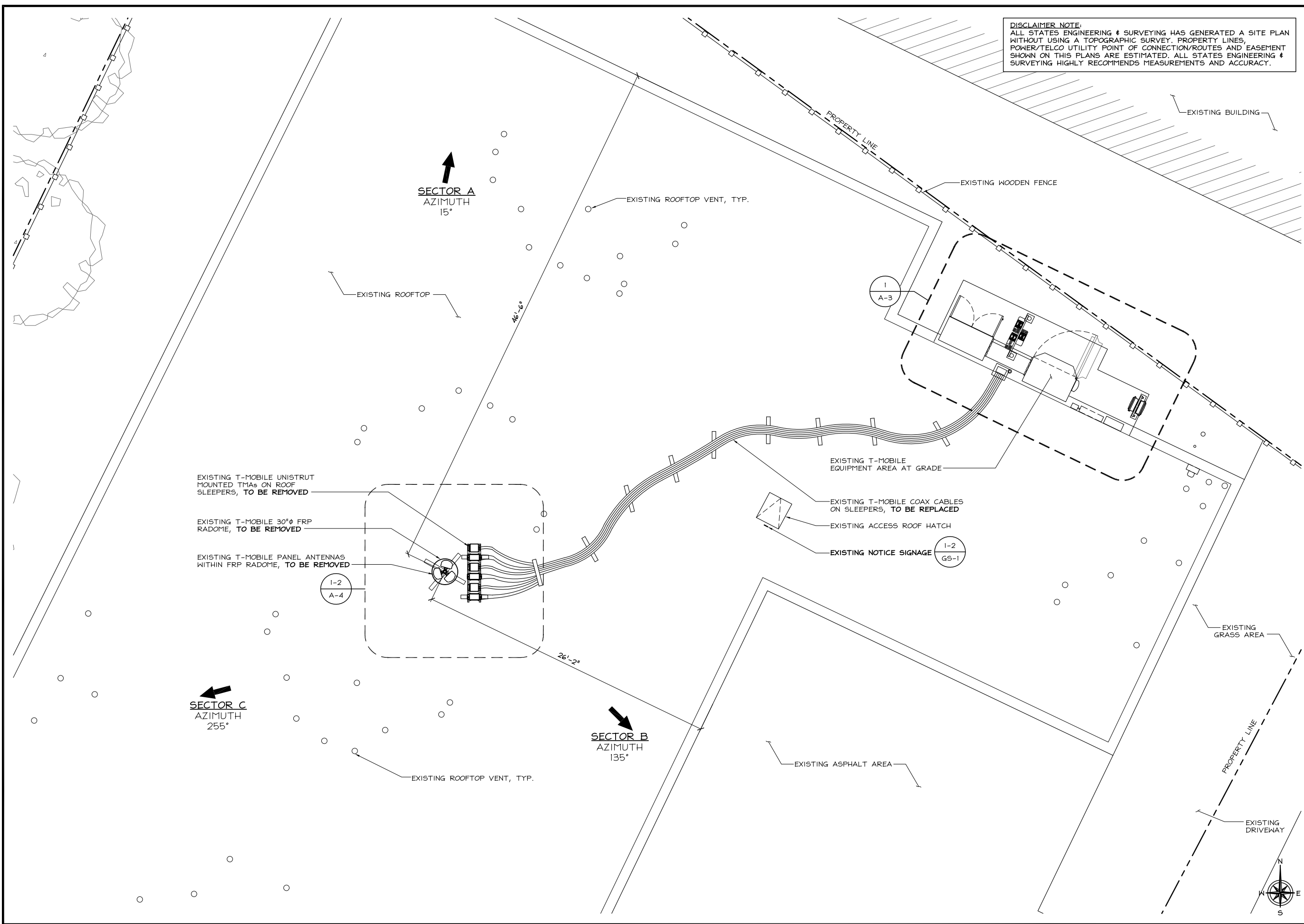

**DISCLAIMER NOTE:**  
ALL STATES ENGINEERING & SURVEYING HAS GENERATED A SITE PLAN WITHOUT USING A TOPOGRAPHIC SURVEY. PROPERTY LINES, POWER/TELCO UTILITY POINT OF CONNECTION/ROUTES AND EASEMENT SHOWN ON THIS PLANS ARE ESTIMATED. ALL STATES ENGINEERING & SURVEYING HIGHLY RECOMMENDS MEASUREMENTS AND ACCURACY.

**T-Mobile**  
1200 CONCORD AVE., SUITE 500  
CONCORD, CA 94520

**NETWORK CONNEX**  
416 AVIATION BLVD, SUITE B  
SANTA ROSA, CA 95403

**ALL STATES**  
ENGINEERING & SURVEYING  
23675 BIRTCHEER DRIVE  
LAKE FOREST, CA 92630

PROJECT NO:	SF03171A
DRAWN BY:	SS
CHECKED BY:	KM

REV	DATE	DESCRIPTION	
1	11/22/2023	REVISE FRP SCREEN	RN
0	06/14/2023	100% CD'S FOR SUBMITTAL	MG
B	12/16/2022	95% FOR APPROVAL	MG
A	12/06/2022	90% CD'S FOR REVIEW	MG

REGISTERED PROFESSIONAL ENGINEER  
MESSAM ZALZALI  
71655  
CIVIL  
STATE OF CALIFORNIA  
*M. Zalzali*

IT IS A VIOLATION OF LAW FOR ANY PERSON, UNLESS THEY ARE ACTING UNDER THE DIRECTION OF A LICENSED PROFESSIONAL ENGINEER, TO ALTER THIS DOCUMENT.

SF03171A  
ATHERTON #5  
201 4TH AVE  
REDWOOD CITY, CA 94063  
ANCHOR PROJECT

SHEET TITLE  
EXISTING ENLARGED  
SITE PLAN

SHEET NUMBER  
**A-2**

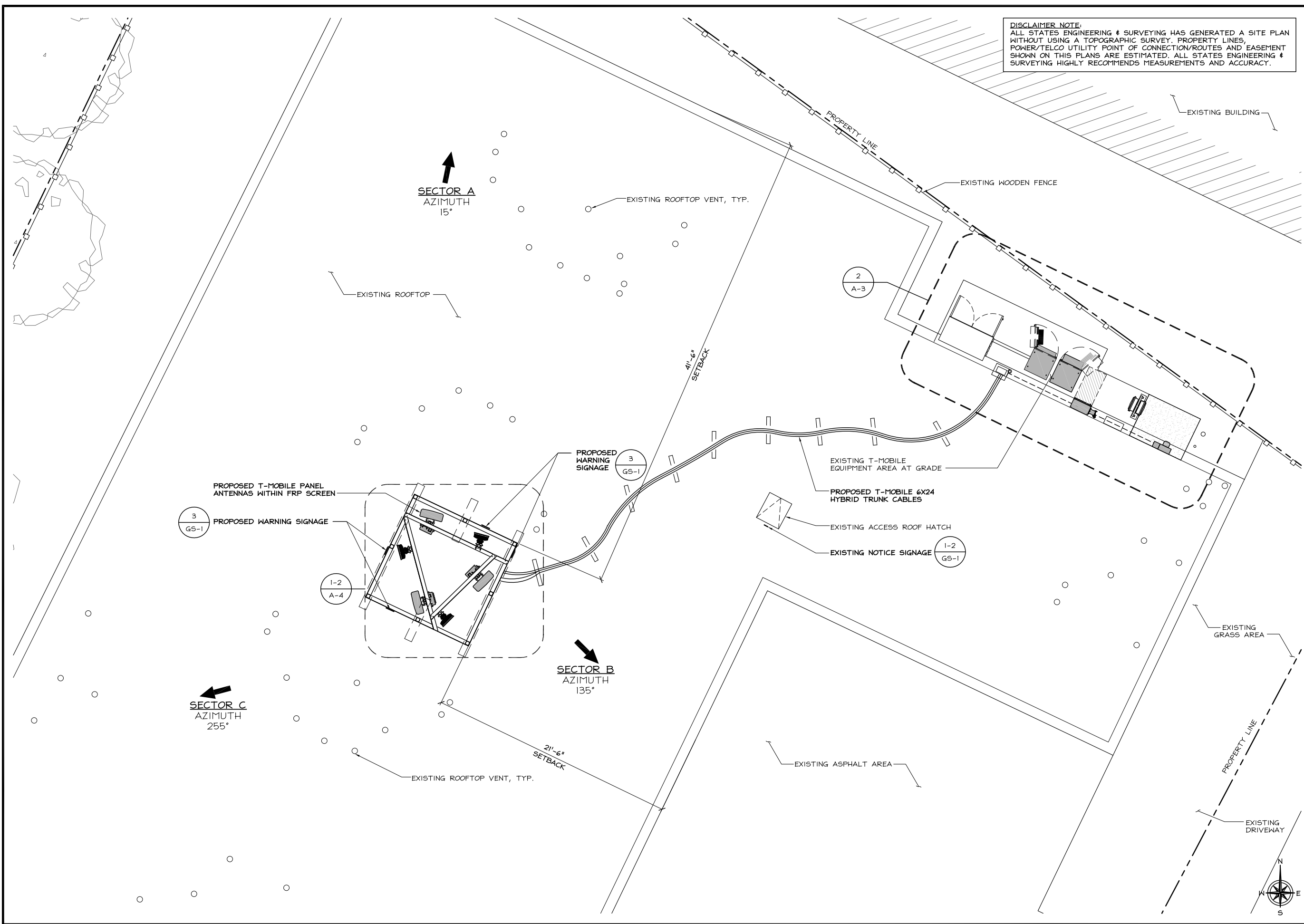

**DISCLAIMER NOTE:**  
 ALL STATES ENGINEERING & SURVEYING HAS GENERATED A SITE PLAN WITHOUT USING A TOPOGRAPHIC SURVEY. PROPERTY LINES, POWER/TELCO UTILITY POINT OF CONNECTION/ROUTES AND EASEMENT SHOWN ON THIS PLANS ARE ESTIMATED. ALL STATES ENGINEERING & SURVEYING HIGHLY RECOMMENDS MEASUREMENTS AND ACCURACY.

**T-Mobile**  
 1200 CONCORD AVE., SUITE 500  
 CONCORD, CA 94520

**NETWORK CONNEX**  
 416 AVIATION BLVD, SUITE B  
 SANTA ROSA, CA 95403

**ALLSTATES**  
 ENGINEERING & SURVEYING  
 23675 BIRTCHEER DRIVE  
 LAKE FOREST, CA 92630

PROJECT NO: SF03171A  
 DRAWN BY: SS  
 CHECKED BY: KM

REV	DATE	DESCRIPTION	
I	11/22/2023	REVISE FRP SCREEN	RN
O	06/14/2023	100% CD'S FOR SUBMITTAL	MG
B	12/16/2022	95% FOR APPROVAL	MG
A	12/06/2022	90% CD'S FOR REVIEW	MG

REGISTERED PROFESSIONAL ENGINEER  
 WISSAM ZALZALI  
 71655  
 CIVIL  
 STATE OF CALIFORNIA  
*W. Zalzali*

IT IS A VIOLATION OF LAW FOR ANY PERSON, UNLESS THEY ARE ACTING UNDER THE DIRECTION OF A LICENSED PROFESSIONAL ENGINEER, TO ALTER THIS DOCUMENT.

SF03171A  
 ATHERTON #5  
 201 4TH AVE  
 REDWOOD CITY, CA 94063  
 ANCHOR PROJECT

SHEET TITLE  
 PROPOSED ENLARGED  
 SITE PLAN

SHEET NUMBER  
**A-2.1**

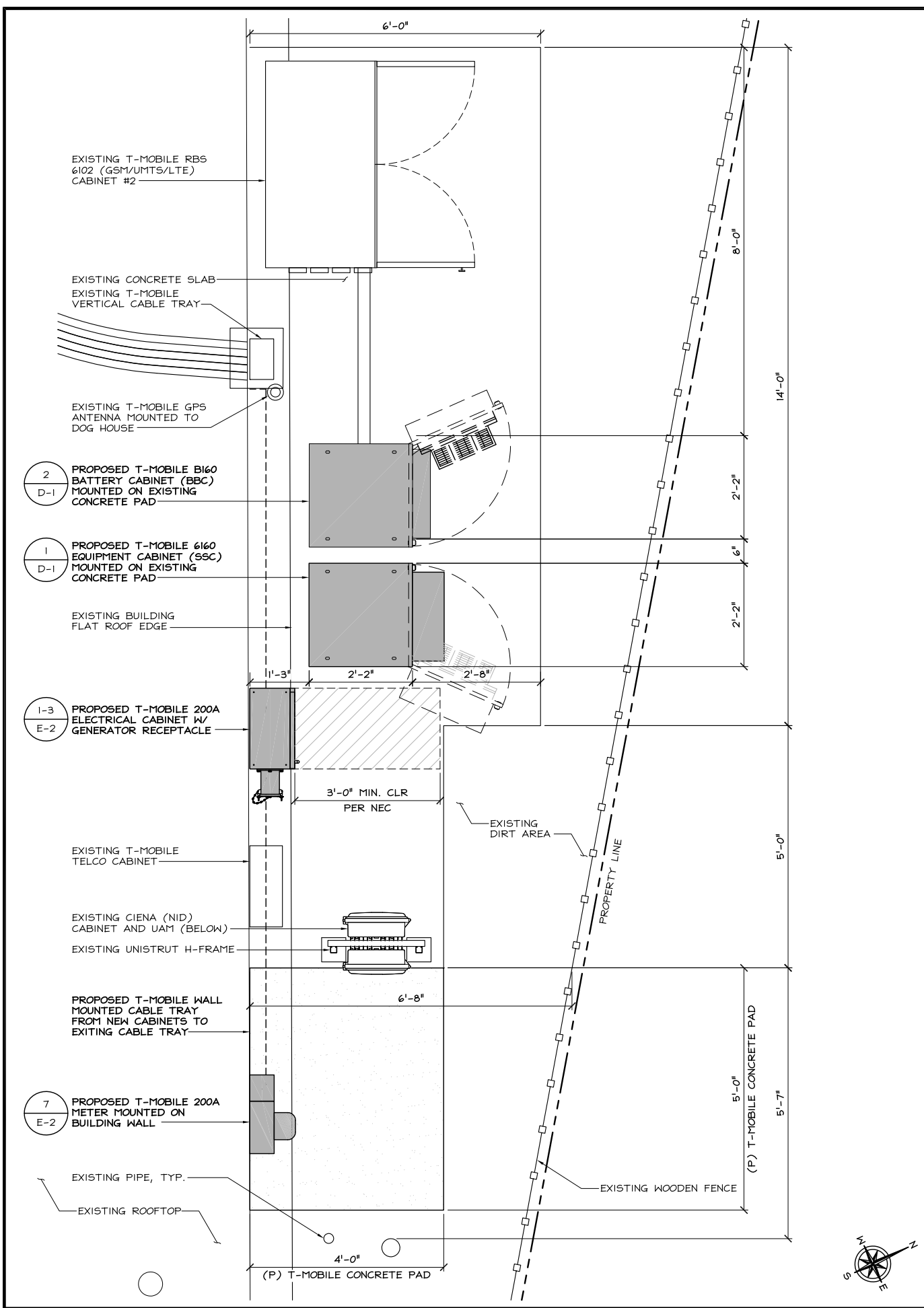

**PROPOSED EQUIPMENT LAYOUT**

24"x36" SCALE: 1/2" = 1'-0"  
 11"x17" SCALE: 1/4" = 1'-0"  
 2' 1' 0' 2'

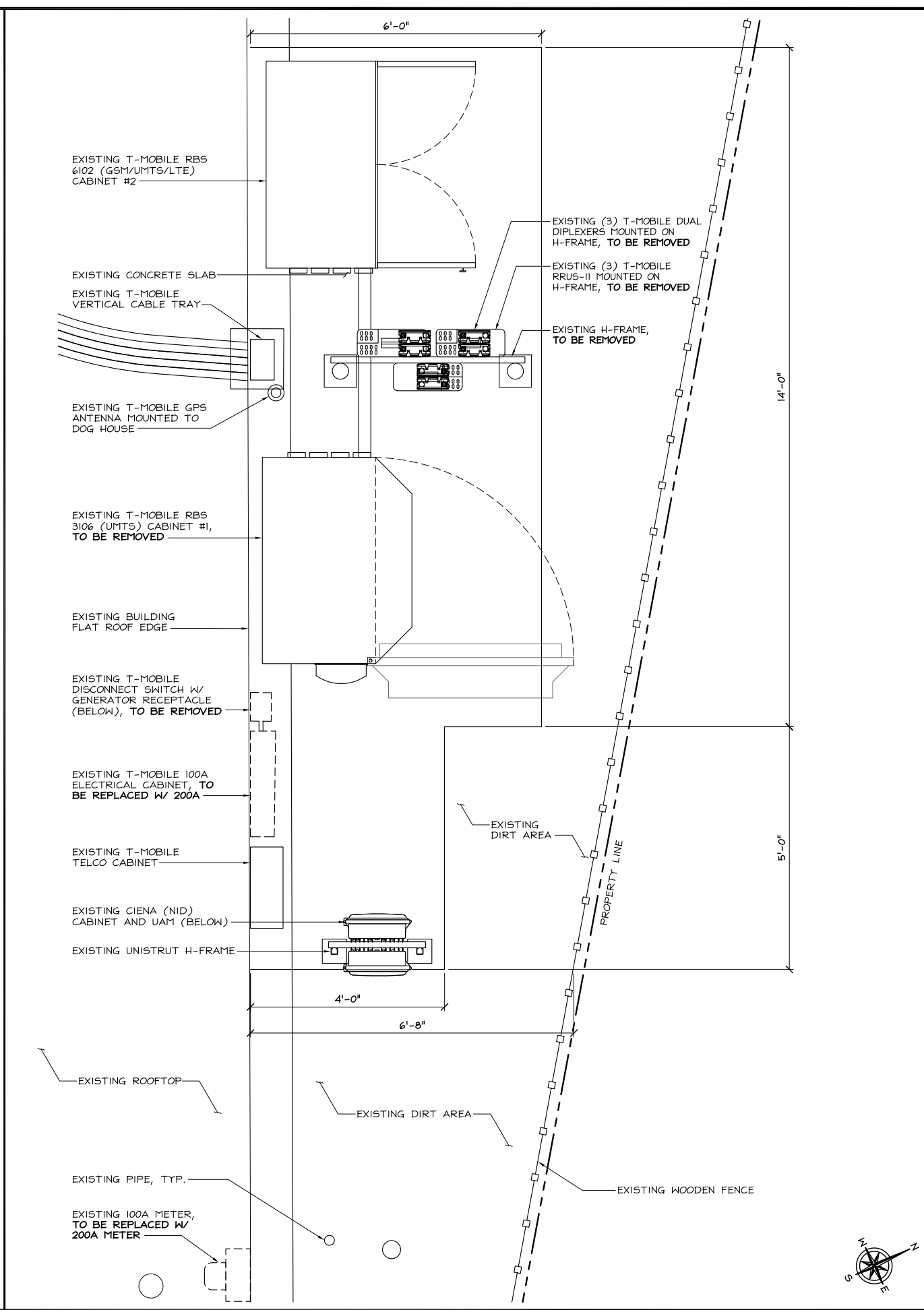

**EXISTING EQUIPMENT LAYOUT**

24"x36" SCALE: 1/2" = 1'-0"  
 11"x17" SCALE: 1/4" = 1'-0"  
 2' 1' 0' 2'



1200 CONCORD AVE., SUITE 500  
 CONCORD, CA 94520



416 AVIATION BLVD, SUITE B  
 SANTA ROSA, CA 95403



23675 BIRTCHE DRIVE  
 LAKE FOREST, CA 92630

PROJECT NO:	SF03171A
DRAWN BY:	SS
CHECKED BY:	KM

REV	DATE	DESCRIPTION	
I	11/22/2023	REVISE FRP SCREEN	RN
O	06/14/2023	100% CD'S FOR SUBMITTAL	MG
B	12/16/2022	95% FOR APPROVAL	MG
A	12/06/2022	90% CD'S FOR REVIEW	MG



IT IS A VIOLATION OF LAW FOR ANY PERSON,  
 UNLESS THEY ARE ACTING UNDER THE  
 DIRECTION OF A LICENSED PROFESSIONAL  
 ENGINEER, TO ALTER THIS DOCUMENT.

SF03171A  
 ATHERTON #5  
 201 4TH AVE  
 REDWOOD CITY, CA 94063  
 ANCHOR PROJECT

SHEET TITLE  
**EQUIPMENT LAYOUT  
 PLANS**

SHEET NUMBER  
**A-3**

**NOTE TO CONTRACTOR:**

CONTRACTOR IS TO REFER TO T-MOBILE'S MOST CURRENT RADIO FREQUENCY DATA SHEET (RFDS) PRIOR TO CONSTRUCTION

PROPOSED ANTENNA KEY														
SECTOR	STATUS	ANTENNA NUMBER	BEAM WIDTH	ANTENNA VENDOR	ANTENNA MODEL	AZIMUTH	ELECTRICAL DOWNTILT	MECHANICAL DOWNTILT	RAD CENTER	TYPE	COAXIAL FEEDER		FIBER/HYBRID CABLE FEEDER	
											SIZE	LENGTH	SIZE	LENGTH
ALPHA	PROPOSED	A-1	65°	RFS	APXVALL24_43-U-NA20	15°	4/4/4/4	0	32'-0"	L700/L600/ G1900/L1900/ N1900/L2100	-	-	(6) FIBER	10'
	PROPOSED	A-2	65°	ERICSSON	AR-6419_B41	15°	3/3	0	32'-0"	N2500	-	-	(2) FIBER	10'
BETA	PROPOSED	B-1	65°	RFS	APXVALL24_43-U-NA20	135°	4/4/4/4	0	32'-0"	L700/L600/ G1900/L1900/ N1900/L2100	-	-	(6) FIBER	10'
	PROPOSED	B-2	65°	ERICSSON	AR-6419_B41	135°	3/3	0	32'-0"	N2500	-	-	(2) FIBER	10'
GAMMA	PROPOSED	C-1	65°	RFS	APXVALL24_43-U-NA20	255°	4/4/4/4	0	32'-0"	L700/L600/ G1900/L1900/ N1900/L2100	-	-	(6) FIBER	10'
	PROPOSED	C-2	65°	ERICSSON	AR-6419_B41	255°	3/3	0	32'-0"	N2500	-	-	(2) FIBER	10'

PROPOSED RRU KEY						
RRU SECTOR	RRU VENDOR	EQUIP.	MODEL NO.	EQUIP. CENTER	QTY.	STATUS
1-3	ERICSSON	RRU	4480_B71+B85	ANTENNA	3	PROPOSED
1-3	ERICSSON	RRU	4480_B25+B86	ANTENNA	3	PROPOSED

L6 AND ANCHOR COMBINED SOW : -  
 SWAP EXISTING ANTENNA WITH AN OCTO ANTENNA  
 ADD RADIO 4480 FOR LB  
 ADD RADIO 4480 FOR MB  
 ADD AN AIR 6419 FOR B41  
 REMOVE EXISTING TMAS AND DIPLEXERS  
 REMOVE COAX CABLES

EXISTING ANTENNA KEY														
SECTOR	STATUS	ANTENNA NUMBER	BEAM WIDTH	ANTENNA VENDOR	ANTENNA MODEL	AZIMUTH	ELECTRICAL DOWNTILT	MECHANICAL DOWNTILT	RAD CENTER	TYPE	COAXIAL FEEDER		HYBRID CABLE FEEDER	
											SIZE	LENGTH	SIZE	LENGTH
ALPHA	EXISTING	A-1	65°	RFS	APXVFW18X-C-NA20 (HEX)	15°	-	-	33'-0"	L2100 L700 U1900/L1900	(3) 7/8" COAX	75'	-	-
BETA	EXISTING	B-1	65°	RFS	APXVFW18X-C-NA20 (HEX)	135°	-	-	33'-0"	L2100 L700 U1900/L1900	(3) 7/8" COAX	75'	-	-
GAMMA	EXISTING	C-1	65°	RFS	APXVFW18X-C-NA20 (HEX)	255°	-	-	33'-0"	L2100 L700 U1900/L1900	(3) 7/8" COAX	75'	-	-

EXISTING RRU KEY						
RRU SECTOR	RRU VENDOR	EQUIP.	MODEL NO.	EQUIP. CENTER	QTY.	STATUS
1-3	ERICSSON	RRU	RRU11 B12	ANTENNA	3	EXISTING

- NOTES:**
- MATERIALS IN FRONT AND SIDE OF ANTENNAS MUST BE RF TRANSPARENT TO MINIMIZE PIM ISSUES.
  - PLEASE MAKE SURE NO RUSTS ON COMPONENTS AND NO LOOSE CONNECTIONS.
  - ENSURE THERE ARE NO PIM ISSUES DURING INSTALLATION.
  - ANTENNAS CAN'T SHOOT INTO METAL, OTHER OPERATOR ANTENNAS, ANYTHING THAT CAN CAUSE PIM ETC.
  - NO ANTENNA SHADOWING. ALL ANTENNAS TO BE CO-PLANAR.
  - RADIOS CANNOT TOUCH ANTENNAS.
  - IF THERE IS PARAPET WALL, BOTTOM OF ALL ANTENNAS MUST BE ABOVE HIGHEST POINT.
  - CALL OUT USE OF CONCEALFAB PIM SHIELD KIT.

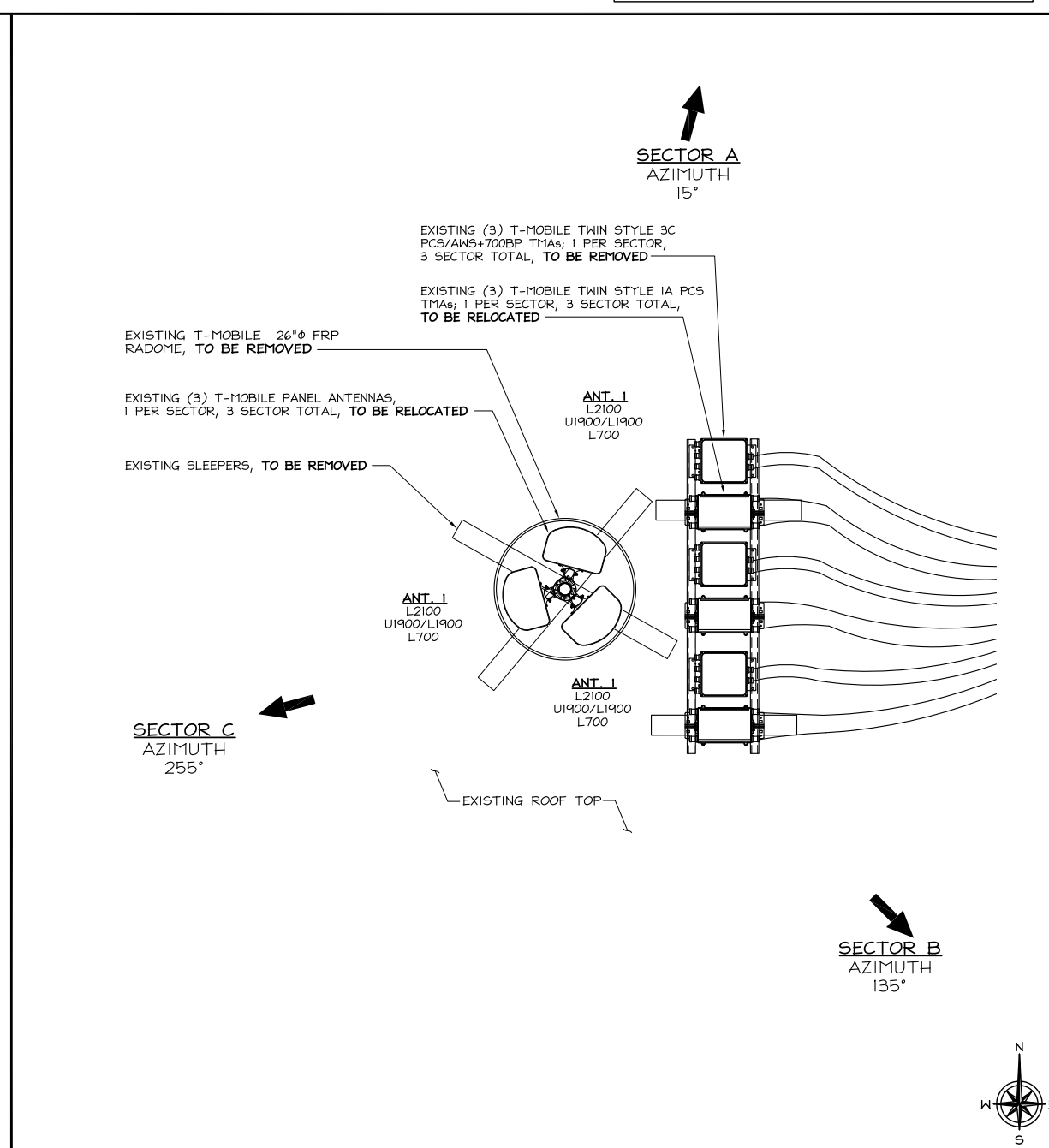
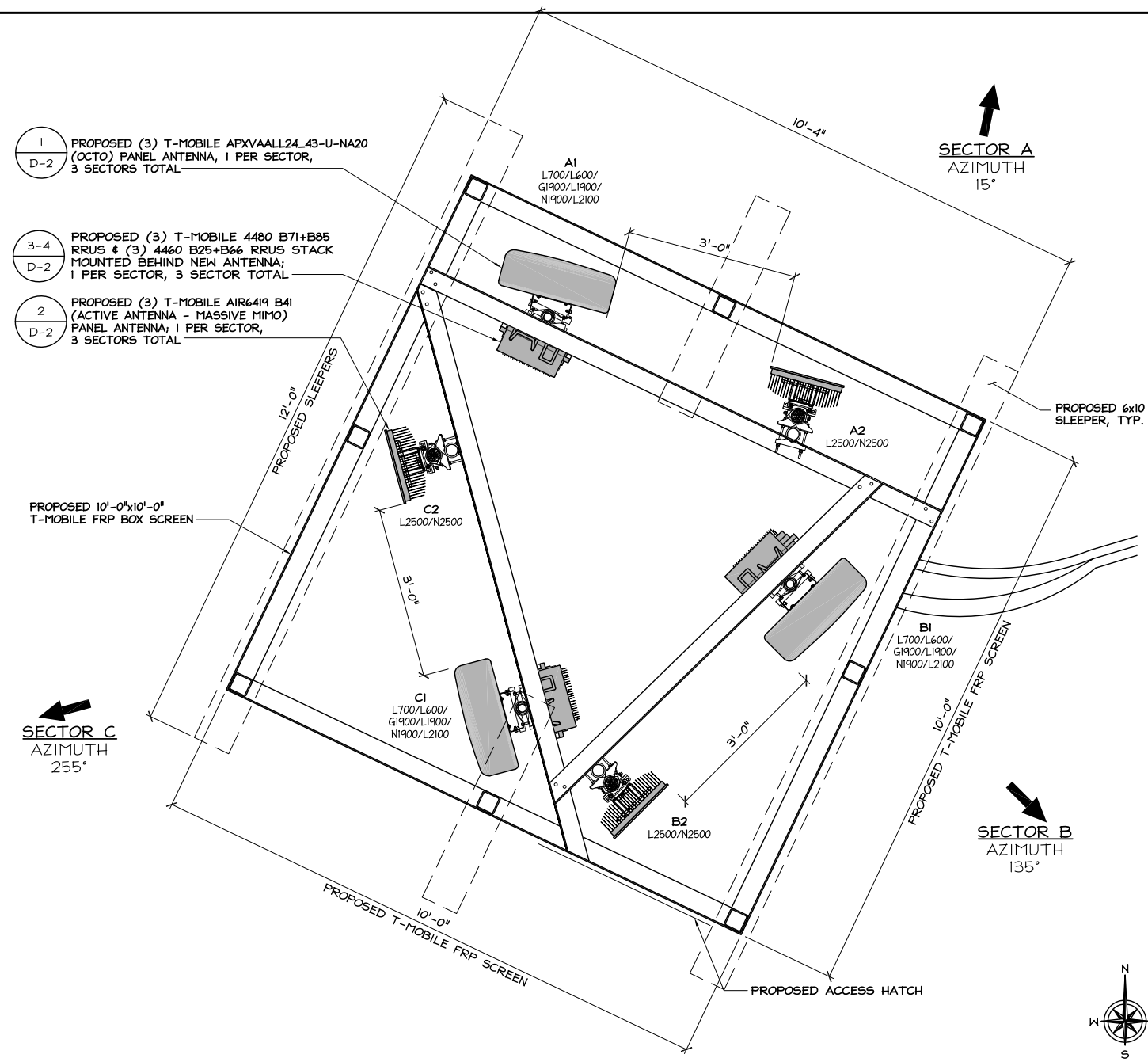

1200 CONCORD AVE., SUITE 500  
CONCORD, CA 94520



416 AVIATION BLVD, SUITE B  
SANTA ROSA, CA 95403

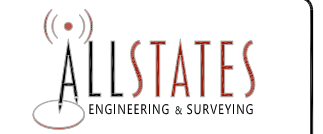

23675 BIRTCHEER DRIVE  
LAKE FOREST, CA 92630

PROJECT NO: SF03171A  
 DRAWN BY: SS  
 CHECKED BY: KM

REV	DATE	DESCRIPTION	BY
I	11/22/2023	REVISE FRP SCREEN	RN
O	06/14/2023	100% CD'S FOR SUBMITTAL	MG
B	12/16/2022	95% FOR APPROVAL	MG
A	12/16/2022	90% CD'S FOR REVIEW	MG



IT IS A VIOLATION OF LAW FOR ANY PERSON, UNLESS THEY ARE ACTING UNDER THE DIRECTION OF A LICENSED PROFESSIONAL ENGINEER, TO ALTER THIS DOCUMENT.

SF03171A  
 ATHON #5  
 201 4TH AVE  
 REDWOOD CITY, CA 94063  
 ANCHOR PROJECT

SHEET TITLE  
 ANTENNA LAYOUT PLANS

SHEET NUMBER  
**A-4**



NOTE:  
PROPOSED FRP SCREEN TO BE PAINTED  
TO MATCH EXISTING BUILDING

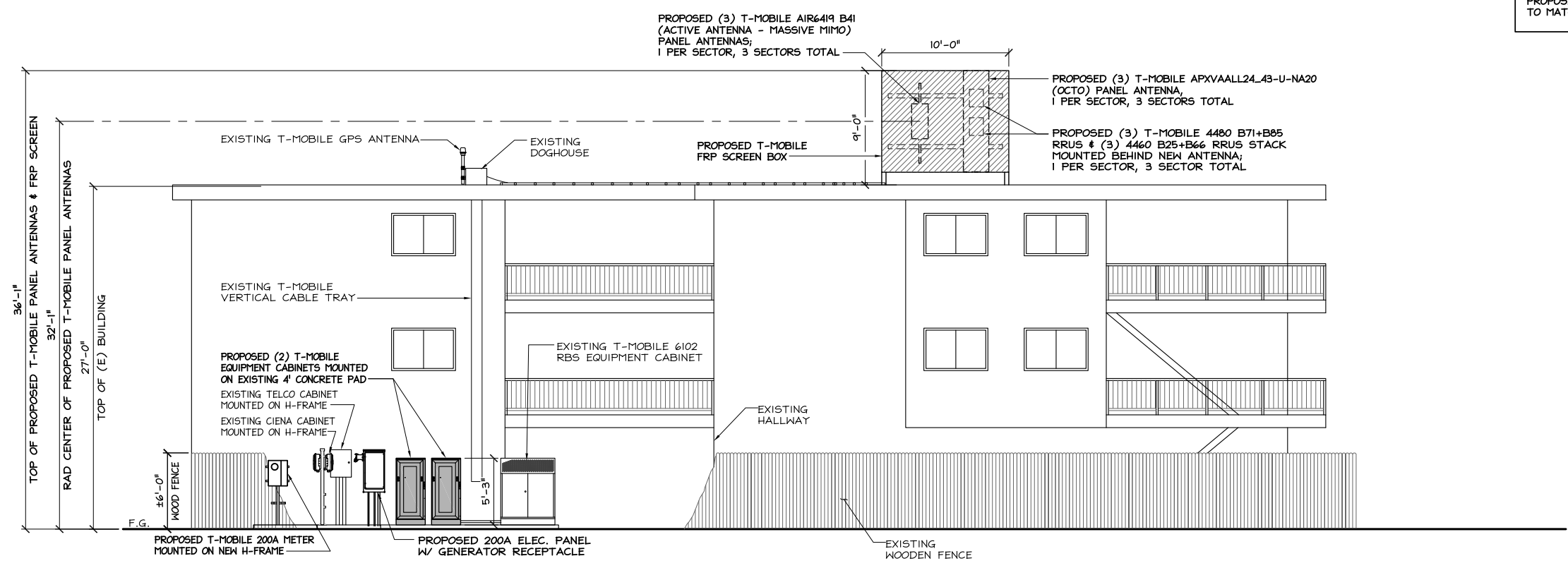

**PROPOSED NORTHEAST ELEVATION**

24"x36" SCALE: 3/16" = 1'-0"  
11"x17" SCALE: 3/32" = 1'-0"  
4' 2' 0" 4' **2**

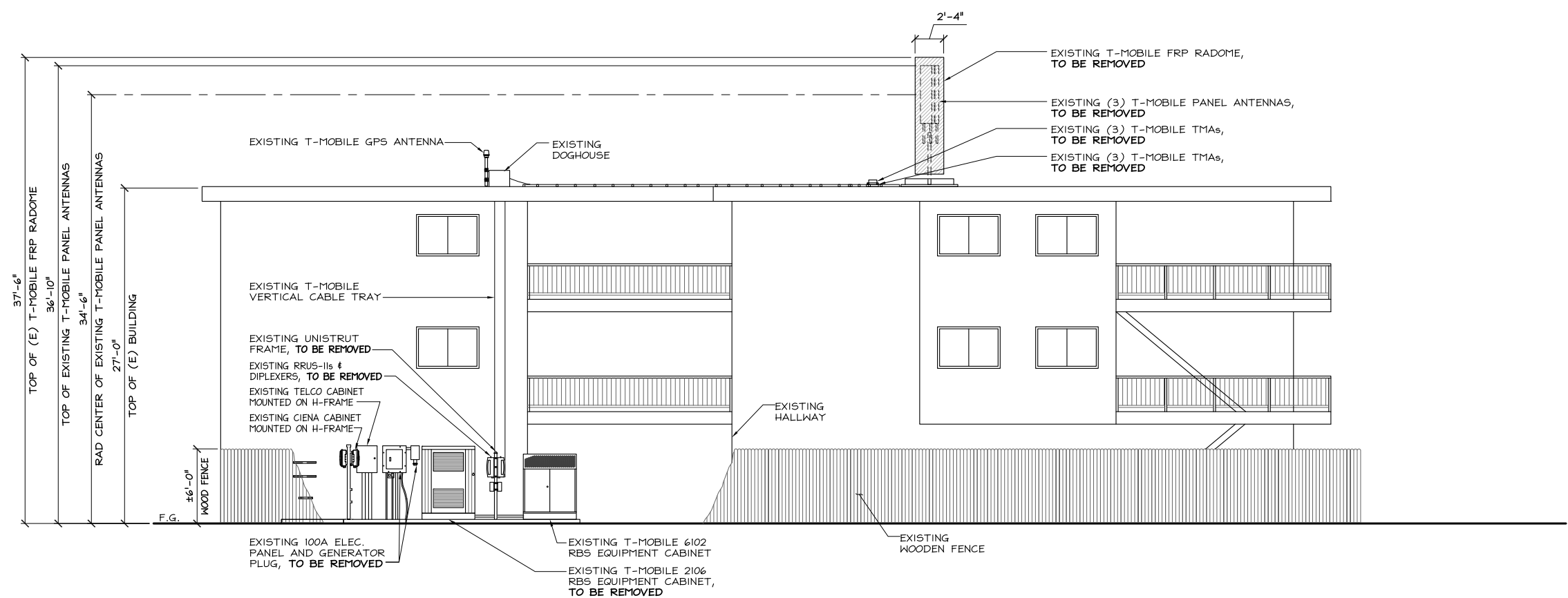

**EXISTING NORTHEAST ELEVATION**

24"x36" SCALE: 1/8" = 1'-0"  
11"x17" SCALE: 1/16" = 1'-0"  
8' 6' 4' 2' 0" 8' **1**

**T-Mobile**  
1200 CONCORD AVE., SUITE 500  
CONCORD, CA 94520

**NETWORK CONNEX**  
416 AVIATION BLVD, SUITE B  
SANTA ROSA, CA 95403

**ALLSTATES**  
ENGINEERING & SURVEYING  
23675 BIRTCHE DRIVE  
LAKE FOREST, CA 92630

PROJECT NO:	SF03171A
DRAWN BY:	SS
CHECKED BY:	KM

REV	DATE	DESCRIPTION	
I	11/22/2023	REVISE FRP SCREEN	RN
O	06/14/2023	100% CD'S FOR SUBMITTAL	MG
B	12/16/2022	95% FOR APPROVAL	MG
A	12/06/2022	90% CD'S FOR REVIEW	MG

REGISTERED PROFESSIONAL ENGINEER  
MUSAW ZALZALI  
71655  
CIVIL  
STATE OF CALIFORNIA  
*M. Alshab*

IT IS A VIOLATION OF LAW FOR ANY PERSON,  
UNLESS THEY ARE ACTING UNDER THE  
DIRECTION OF A LICENSED PROFESSIONAL  
ENGINEER, TO ALTER THIS DOCUMENT.

SF03171A  
ATHERTON #5  
201 4TH AVE  
REDWOOD CITY, CA 94063  
ANCHOR PROJECT

SHEET TITLE  
ELEVATIONS

SHEET NUMBER  
**A-5**





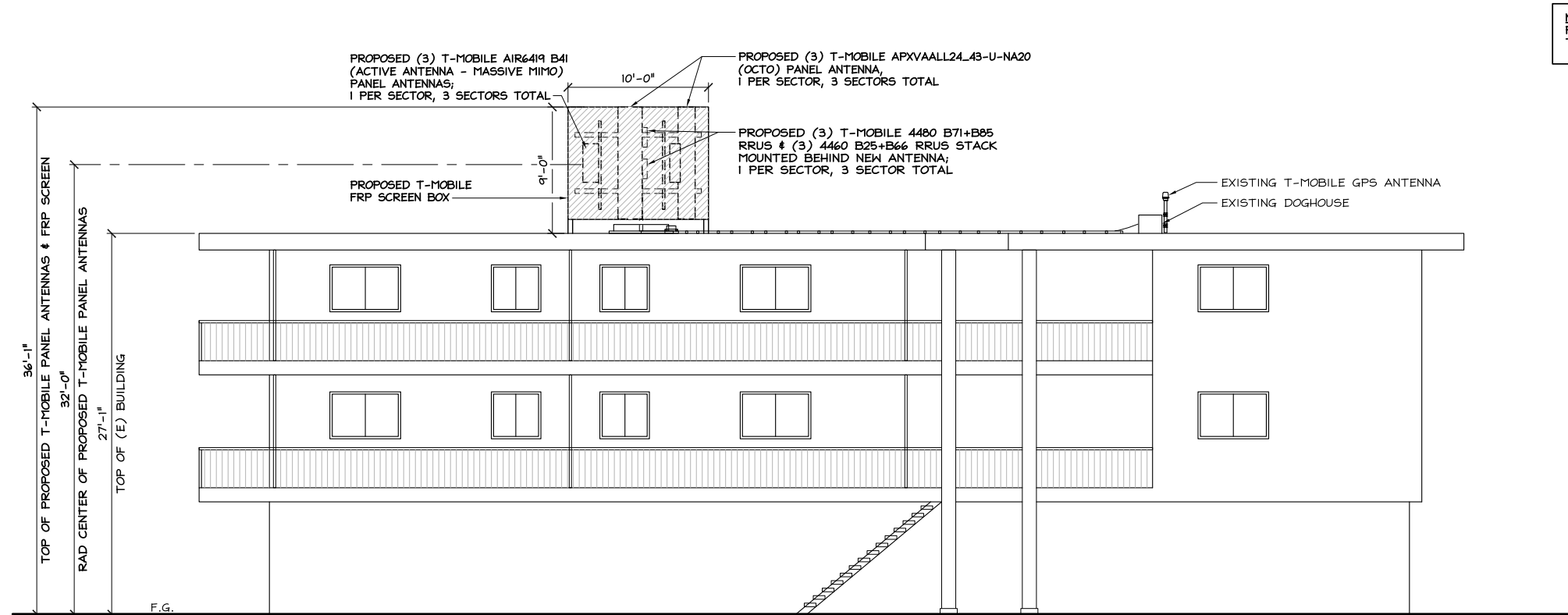

NOTE:  
PROPOSED FRP SCREEN TO BE PAINTED  
TO MATCH EXISTING BUILDING

**PROPOSED SOUTHWEST ELEVATION**

24"x36" SCALE: 3/16" = 1'-0"  
11"x17" SCALE: 3/32" = 1'-0"  
4' 2' 0" 4' **2**

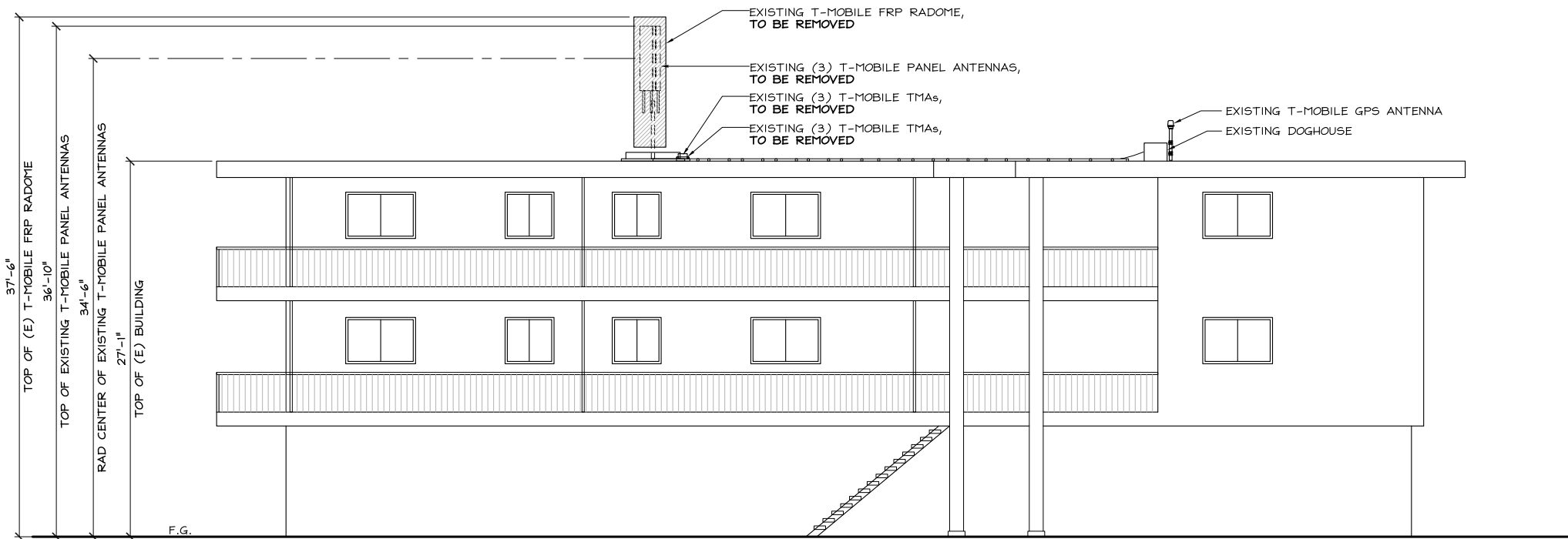

**EXISTING SOUTHWEST ELEVATION**

24"x36" SCALE: 1/8" = 1'-0"  
11"x17" SCALE: 1/16" = 1'-0"  
8' 6' 4' 2' 0" 8' **1**

1200 CONCORD AVE., SUITE 500  
CONCORD, CA 94520

416 AVIATION BLVD, SUITE B  
SANTA ROSA, CA 95403

23675 BIRTCHEr DRIVE  
LAKE FOREST, CA 92630

PROJECT NO:	SF03171A
DRAWN BY:	SS
CHECKED BY:	KM

REV	DATE	DESCRIPTION	BY
I	11/22/2023	REVISE FRP SCREEN	RN
O	06/14/2023	100% CD's FOR SUBMITTAL	MG
B	12/16/2022	95% FOR APPROVAL	MG
A	12/06/2022	90% CD's FOR REVIEW	MG

REV	DATE	DESCRIPTION	BY
I	11/22/2023	REVISE FRP SCREEN	RN
O	06/14/2023	100% CD's FOR SUBMITTAL	MG
B	12/16/2022	95% FOR APPROVAL	MG
A	12/06/2022	90% CD's FOR REVIEW	MG

IT IS A VIOLATION OF LAW FOR ANY PERSON,  
UNLESS THEY ARE ACTING UNDER THE  
DIRECTION OF A LICENSED PROFESSIONAL  
ENGINEER, TO ALTER THIS DOCUMENT.

SF03171A  
ATHERTON #5  
201 4TH AVE  
REDWOOD CITY, CA 94063  
ANCHOR PROJECT

SHEET TITLE  
ELEVATIONS

SHEET NUMBER  
**A-7**



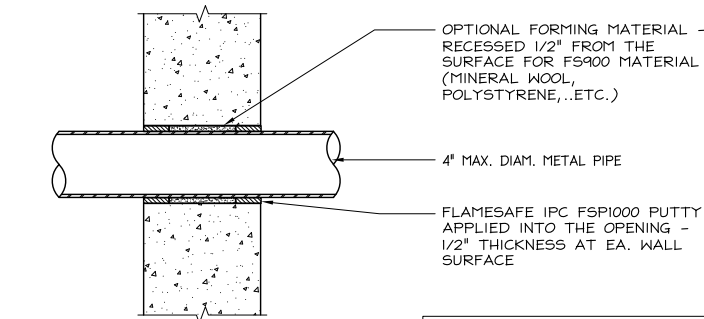
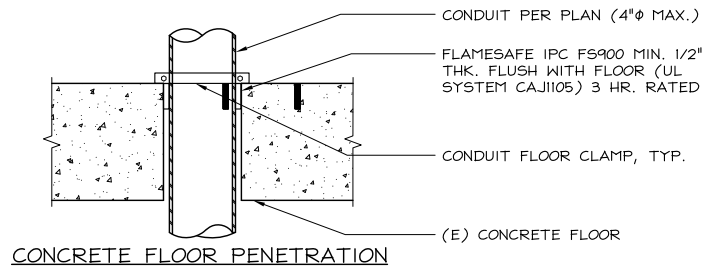

"A" = DIA. OF CROWN DIAMETER TO BE THE DIAMETER OF THE WALL OPENING PLUS 1"

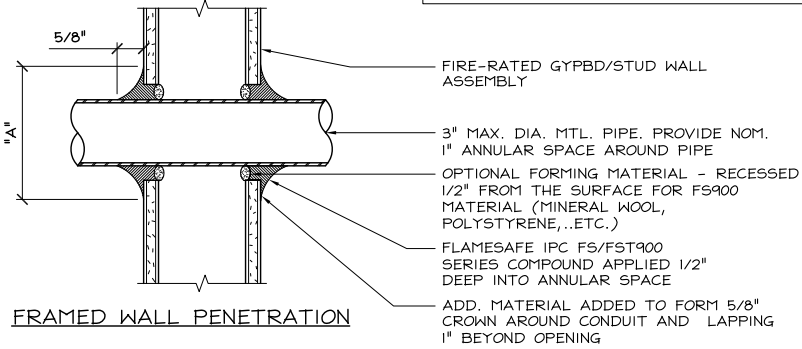

- NOTES:**
- ALL PENETRATIONS SHALL CONFORM TO TITLE 24, CALIF. BLDG. CODE, SECTION 714.
  - PENETRATIONS THRU WALLS SHALL COMPLY WITH T24, CBC SECTION 709.6:  
F RATING - PENETRATIONS 4" OR LESS  
T RATING - PENETRATIONS LARGER THAN 4", PENETRATIONS CORRIDOR CLGS. WHICH ARE NOT RATED, BELOW ANY CLG.
  - PENETRATIONS THRU FLOORS/ CEILINGS SHALL COMPLY WITH T24, CBC SECTION 710.3:  
F RATING - PENETRATIONS 4" OR LESS  
T RATING - PENETRATIONS LARGER THAN 4", PENETRATIONS NOT CONTAINED WITHIN A WALL.

**CONDUIT PENETRATION DETAIL** 24"x36" SCALE: NTS 11"x17" SCALE: NTS **4**

**ERICSSON RBS-B160 OUTDOOR BATTERY CABINET**

SIZE (HxWxD): 63"x26"x29"  
 WEIGHT (W/ 3 SHELVES OF BATT.): 1833 lbs MAX.  
 REQUIRED WITH EACH NEW 6160 (REGARDLESS OF GENERATOR STATUS)

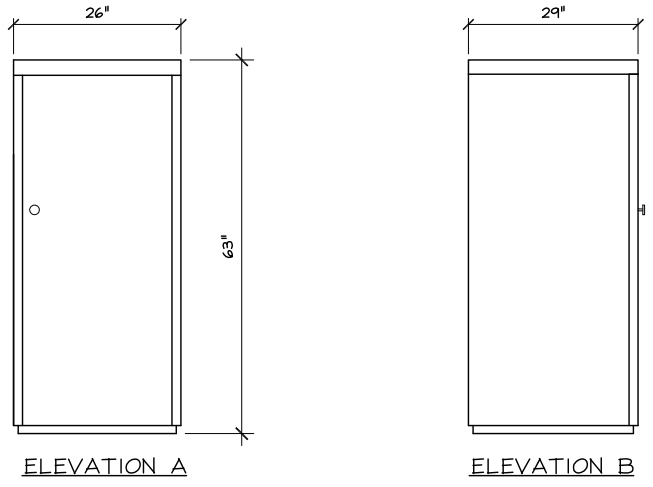

**RBS-B160 BATTERY CABINET** 24"x36" SCALE: NTS 11"x17" SCALE: NTS **2**

**ERICSSON RBS-6160 OUTDOOR EQUIPMENT CABINET**

SIZE (HxWxD): 63"x25"x34"  
 WEIGHT: 605 lbs MAX.  
 FLEXIBLE DC POWER EXPANSION AS NEEDED UP TO 28kW (N+1, 3.5kW x 9 RECTIFIERS)  
 19U RACK SPACE (REQUIRES EXTERNAL BATTERY CABINET)

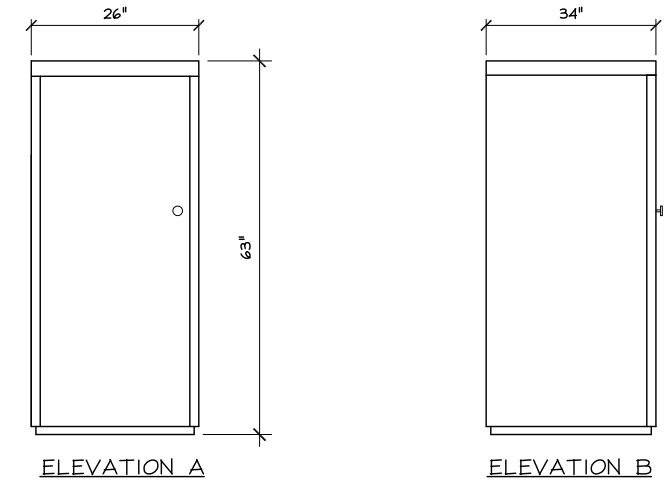

**RBS-6160 RF/POWER CABINET** 24"x36" SCALE: NTS 11"x17" SCALE: NTS **1**

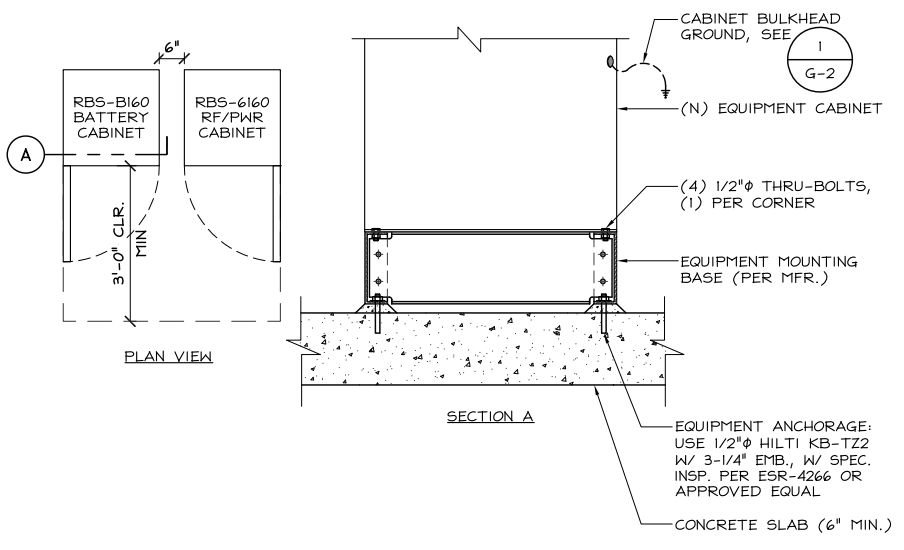

**EQUIPMENT CABINET MOUNTING** 24"x36" SCALE: NTS 11"x17" SCALE: NTS **3**

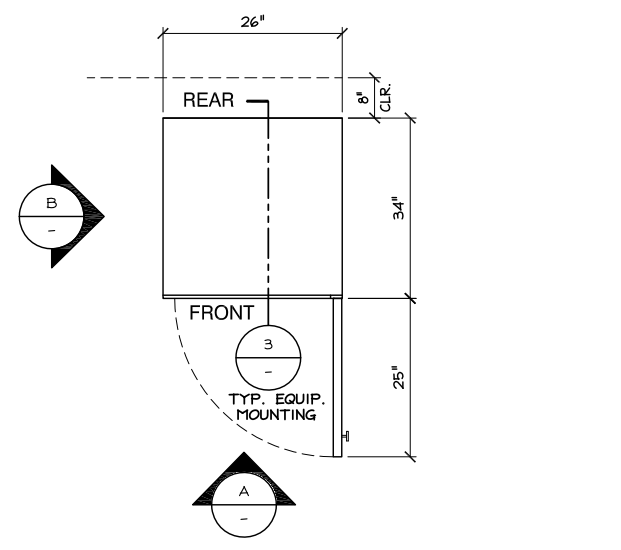
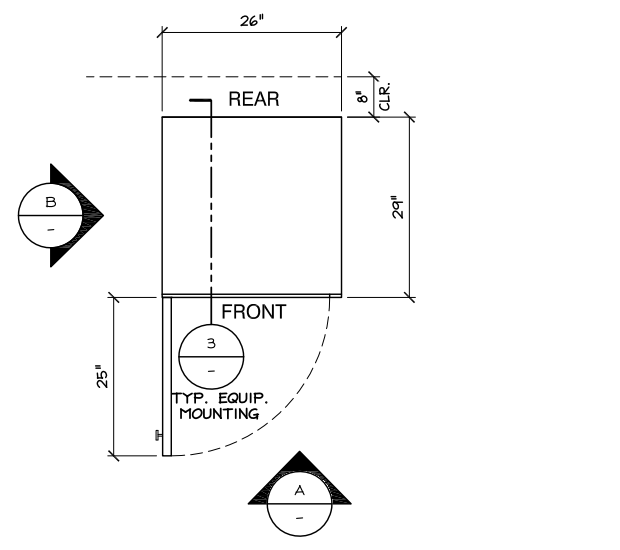

PROJECT NO:	SF03171A
DRAWN BY:	SS
CHECKED BY:	KM

REV	DATE	DESCRIPTION	
I	11/22/2023	REVISE FRP SCREEN	RN
O	06/14/2023	100% CD'S FOR SUBMITTAL	MG
B	12/16/2022	95% FOR APPROVAL	MG
A	12/06/2022	90% CD'S FOR REVIEW	MG

REGISTERED PROFESSIONAL ENGINEER  
 MASSAM ZALZALI  
 71655  
 CIVIL  
 STATE OF CALIFORNIA  
*M. Alshab*

IT IS A VIOLATION OF LAW FOR ANY PERSON, UNLESS THEY ARE ACTING UNDER THE DIRECTION OF A LICENSED PROFESSIONAL ENGINEER, TO ALTER THIS DOCUMENT.

SF03171A  
 ATHON #5  
 201 4TH AVE  
 REDWOOD CITY, CA 94063  
 ANCHOR PROJECT

SHEET TITLE  
 DETAILS

SHEET NUMBER  
**D-1**





MECHANICAL PROPERTIES:	
NUMBER, SIZE (AWG)	10/C #6+2/C #18
VOLTAGE	600
OUTER JACKET	PVC
SHIELDING	CORRUGATED COPPER
DRAIN	N/A
RIPCORDER	KEVLAR
DC CONDUCTOR MATERIAL	COPPER
DC CONDUCTOR SIZE (AWG)	6
COLOR CODE	BLACK/RED
ALARM CONDUCTOR MATERIAL	COPPER
ALARM CONDUCTOR SIZE (AWG)	18
WEIGHT (LB/FT)	1.614
MINIMUM BENDING RADIUS (IN.)	19
BEND MOMENT (LB/FT)	N/A
TENSILE STRENGTH (LB)	340
CRUSH RESISTANCE, FOTP-41 (N/mm)	22
STRENGTH MEMBER	NO
OPERATION TEMPERATURE RANGE (LOW)	-40° C
OPERATION TEMPERATURE RANGE (HIGH)	+80° C

  

ELECTRICAL PROPERTIES:	
VOLTAGE	600
MAX SHIELD RESISTANCE (Ω/FT @ 20° C)	0.0035
MAX DC-RESISTANCE OUTER CONDUCTOR DC (Ω/1000 FT @ 20° C)	0.411
MAX DC-RESISTANCE OUTER CONDUCTOR ARMOR (Ω/1000 FT)	6.7

FIBER OPTIC PROPERTIES:	
TYPE	LOW WATER PEAK, SINGLE MODE, LOOSE TUBE
FIBER STANDARD COMPLIANCE	ITU-T REC. G.652.E, G.657.A2
FIBER COATING DIAMETER (UM)	IEC 60793-2-50 TYPE B.1.3 & TYPE B.6 A&B
FIBER COUNT	36
NUMBER OF FIBER SUBUNITS	1
FIBER COUNT EACH UNITS	36
FIBER OUTER JACKETS	FR JACKET
MAX ATTENUATION 1310 nm (dB/Km)	≤ 0.5
MAX ATTENUATION 1550 nm (dB/Km)	≤ 0.5

REFERENCE ONLY

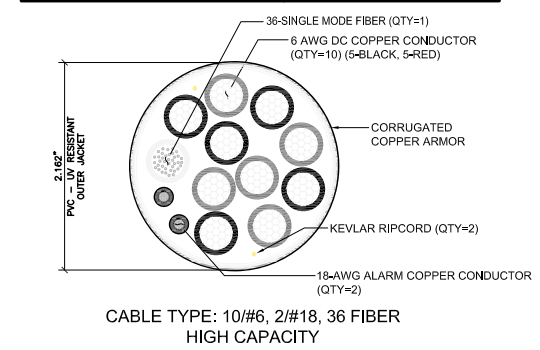

**T-Mobile**  
1200 CONCORD AVE., SUITE 500  
CONCORD, CA 94520

**NETWORK CONNEX**  
416 AVIATION BLVD, SUITE B  
SANTA ROSA, CA 95403

**ALLSTATES**  
ENGINEERING & SURVEYING  
23675 BIRTCHEER DRIVE  
LAKE FOREST, CA 92630

PROJECT NO:	SF03171A
DRAWN BY:	SS
CHECKED BY:	KM

REV	DATE	DESCRIPTION	
I	11/22/2023	REVISE FRP SCREEN	RN
O	06/14/2023	100% CD'S FOR SUBMITTAL	MG
B	12/16/2022	95% FOR APPROVAL	MG
A	12/06/2022	90% CD'S FOR REVIEW	MG

REGISTERED PROFESSIONAL ENGINEER  
MUSAW ZALZALI  
71655  
CIVIL  
STATE OF CALIFORNIA  
*M. Alshab*

IT IS A VIOLATION OF LAW FOR ANY PERSON, UNLESS THEY ARE ACTING UNDER THE DIRECTION OF A LICENSED PROFESSIONAL ENGINEER, TO ALTER THIS DOCUMENT.

SF03171A  
ATHERTON #5  
201 4TH AVE  
REDWOOD CITY, CA 94063  
ANCHOR PROJECT

SHEET TITLE  
DETAILS

SHEET NUMBER  
D-3

NOT USED 24"x36" SCALE: NTS 11"x17" SCALE: NTS 4

HIGH CAPACITY HYBRID CABLE 24"x36" SCALE: NTS 11"x17" SCALE: NTS 2

**SIGNAGE REQUIREMENTS**

NOTE:  
1. WARNING SIGN TO BE MOUNTED AT LOCATIONS SHOWN ON PLANS, AND SIGN TO BE PAINTED A GREY MATTE.  
2. SIGN SHALL COMPLY WITH ANSI C95.2 COLOR, SYMBOL, AND CONTENT CONVENTIONS.

RED BACKGROUND  
YELLOW BACKGROUND  
BLUE BACKGROUND  
WHITE BACKGROUND

CONTRACTOR TO VERIFY PROPER NOMENCLATURE & SIZE OF PLACARD

**NFPA 704 PLACARD**

NOTE:  
SIGNAGE REQUIREMENTS MAY INCLUDE, BUT MAY NOT BE LIMITED TO ABOVE EXAMPLE. SEE SHEET GN-3 FOR BATTERY SPECIFICATIONS/INFORMATION.

24"x36" SCALE: NTS 11"x17" SCALE: NTS 4

**CONCRETE SLAB SECTION DETAIL**

FINAL GRADE SLOPE AWAY FROM CONCRETE  
COMPACTED CRUSHED STONE OR GRAVEL (OPTIONAL; THICKNESS AS REQUIRED)  
#4@12" EA. WAY @ C OF SLAB  
1" CHAMFER (TYP)  
PER PLAN  
EXCAVATE AS REQUIRED TO REMOVE VEGETATION & TOPSOIL, EXPOSE UNDISTURBED NATURAL SUBGRADE & PLACE CRUSHED STONE AS REQUIRED

NOTES:  
1. SEE CONCRETE NOTES  
2. GRAVEL SHALL BE NATURAL OR CRUSHED STONE WITH 100 PERCENT PASSING 1 INCH SIEVE

24"x36" SCALE: NTS 11"x17" SCALE: NTS 3

**RF JUMPER CONNECTION DETAIL**

CABLE TIE  
(3) WRAPS OF INSULATION TAPE (OVERLAPPING 50%)  
(2) STRETCH WRAPPED WRAPS OF SELF AMALGAMATING TAPE (STRETCH 30% OVERLAPPING 50%)  
(1) WRAP OF INSULATION TAPE (OVERLAPPING 50%)

24"x36" SCALE: NTS 11"x17" SCALE: NTS 1

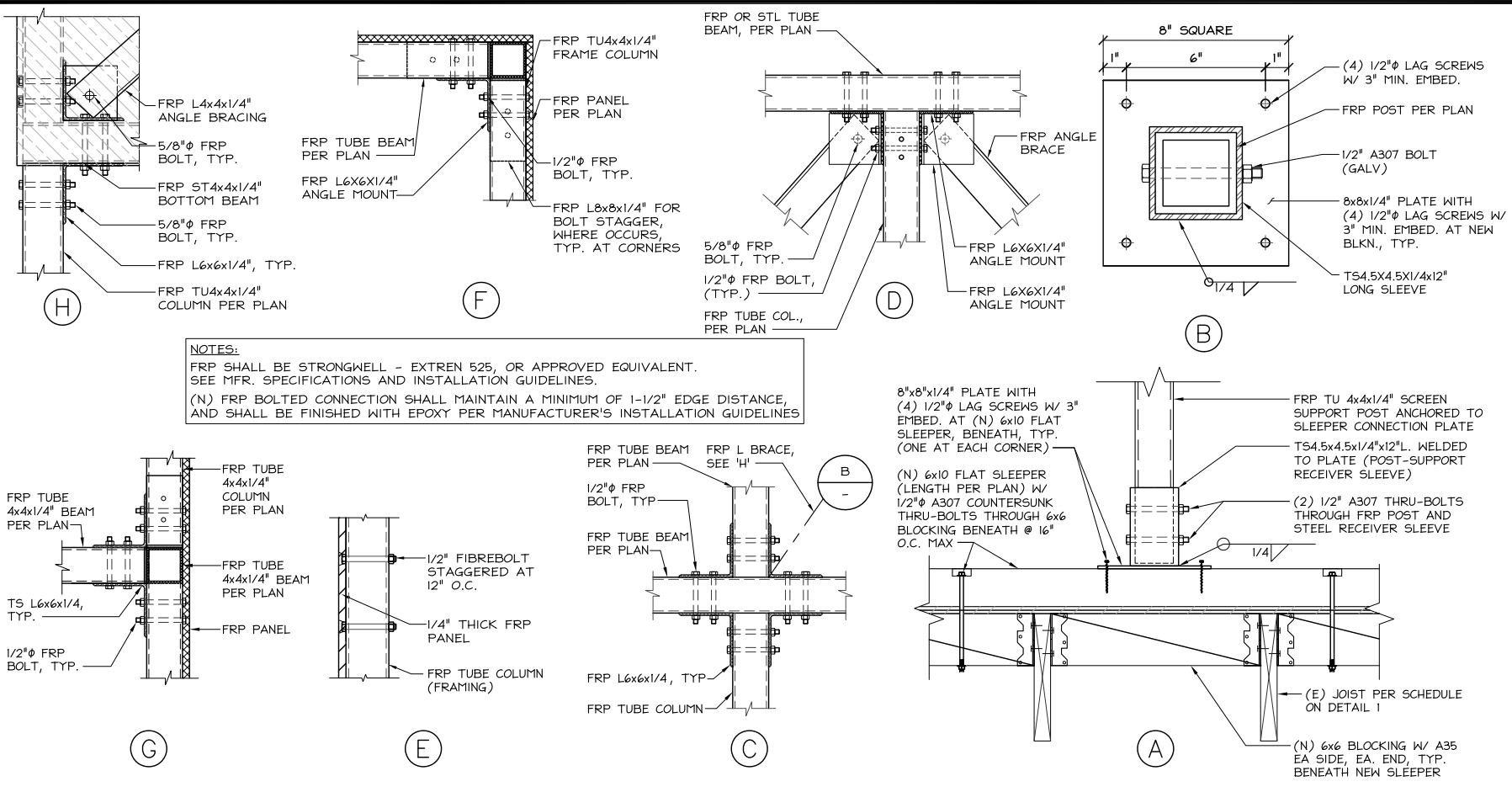

**CONNECTIONS DETAILS** 24"x36" SCALE: NTS 11"x17" SCALE: NTS **4**

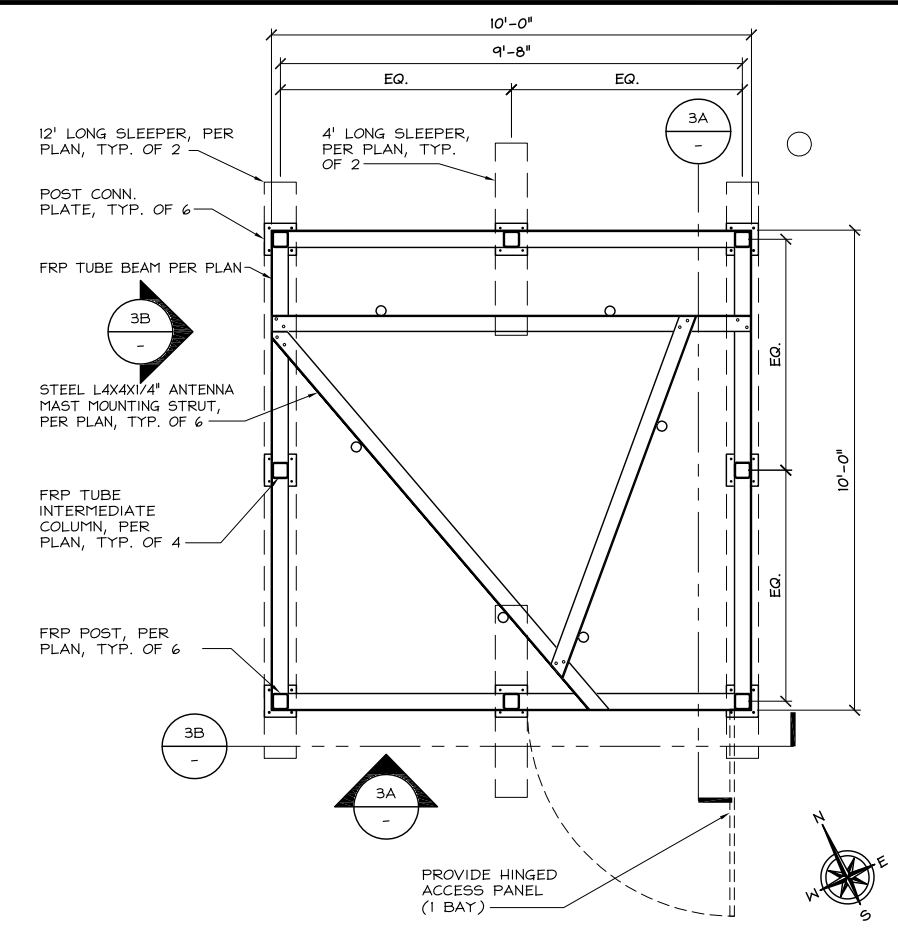

**FRP SCREEN BOX PLAN** 24"x36" SCALE: NTS 11"x17" SCALE: NTS **2**

**(N) Supporting Joist Members**

Member Size	Spacing	Max. Existing Joist Span (ft.)
2x8	@ 24" o.c.	15
2x8	@ 16" o.c.	17
2x10	@ 24" o.c.	17
2x10	@ 16" o.c.	20
2x12	@ 24" o.c.	20
2x12	@ 16" o.c.	24

(N) JOIST SUMMARY

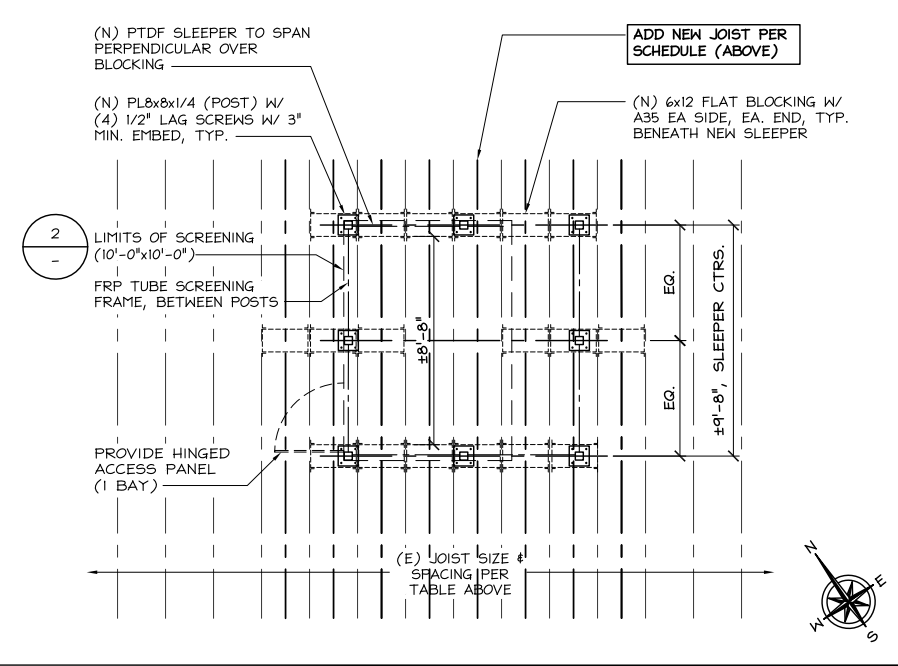

**FRP SCREEN PLAN** 24"x36" SCALE: 1/4" = 1'-0" 11"x17" SCALE: 1/8" = 1'-0" **1**

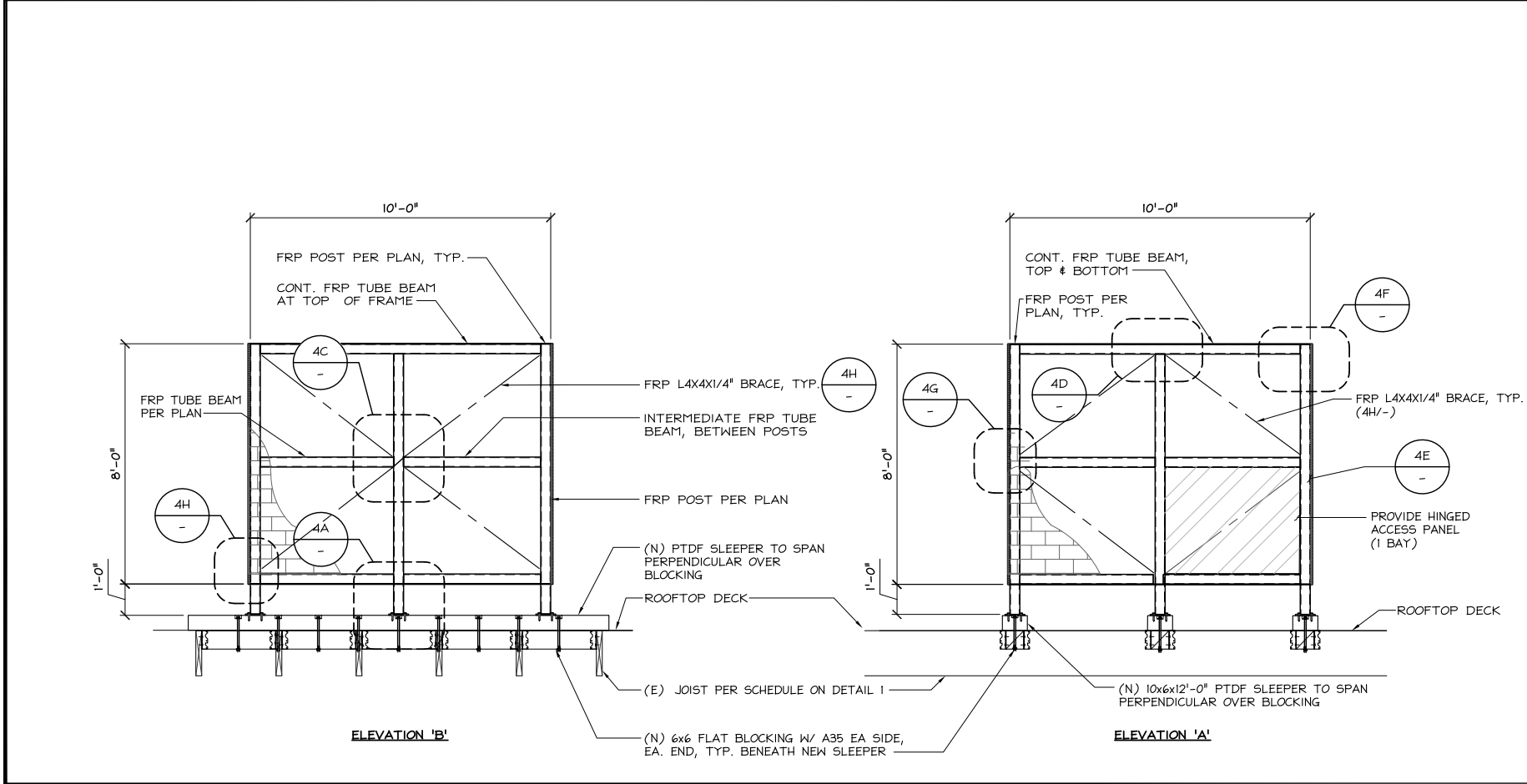

**FRP SCREEN BOX ELEVATIONS** 24"x36" SCALE: 1/2" = 1'-0" 11"x17" SCALE: 1/4" = 1'-0" **3**

**T-Mobile**  
 1200 CONCORD AVE., SUITE 500  
 CONCORD, CA 94520

**NETWORK CONNEX**  
 416 AVIATION BLVD, SUITE B  
 SANTA ROSA, CA 95403

**ALLSTATES**  
 ENGINEERING & SURVEYING  
 23675 BIRTCHEER DRIVE  
 LAKE FOREST, CA 92630

PROJECT NO: SF03171A  
 DRAWN BY: SS  
 CHECKED BY: KM

REV	DATE	DESCRIPTION	BY
I	11/22/2023	REVISE FRP SCREEN	RN
O	06/14/2023	100% CD'S FOR SUBMITTAL	MG
B	12/16/2022	95% FOR APPROVAL	MG
A	12/06/2022	90% CD'S FOR REVIEW	MG

REV	DATE	DESCRIPTION	BY
I	11/22/2023	REVISE FRP SCREEN	RN
O	06/14/2023	100% CD'S FOR SUBMITTAL	MG
B	12/16/2022	95% FOR APPROVAL	MG
A	12/06/2022	90% CD'S FOR REVIEW	MG

REGISTERED PROFESSIONAL ENGINEER  
 WISSAM ZALZALI  
 71655  
 CIVIL  
 STATE OF CALIFORNIA

IT IS A VIOLATION OF LAW FOR ANY PERSON, UNLESS THEY ARE ACTING UNDER THE DIRECTION OF A LICENSED PROFESSIONAL ENGINEER, TO ALTER THIS DOCUMENT.

SF03171A  
 ATHON #5  
 201 4TH AVE  
 REDWOOD CITY, CA 94063  
 ANCHOR PROJECT

SHEET TITLE  
**FRP SCREENING DETAILS**

SHEET NUMBER  
**S-1**



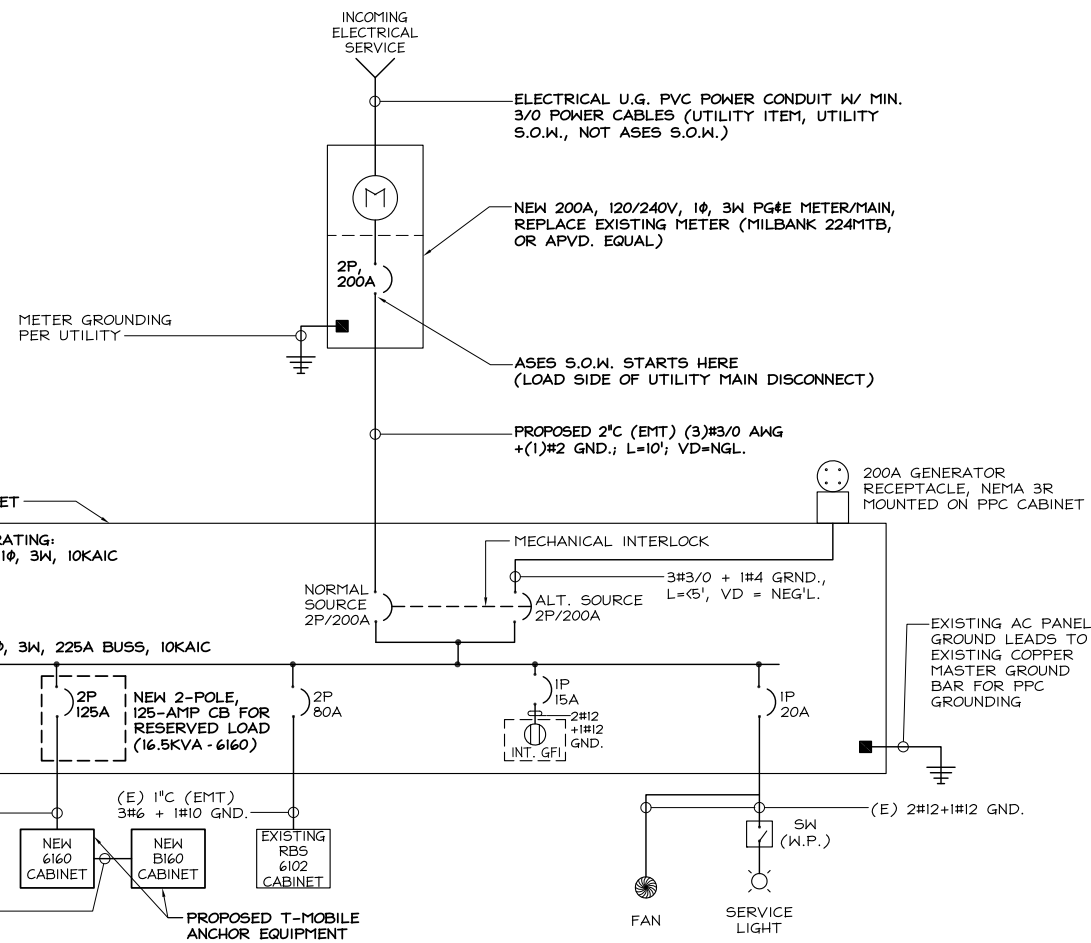

NOTES:

- SUBCONTRACTOR SHALL COORDINATE WITH UTILITY COMPANY BEFORE THE START OF CONSTRUCTION. POWER AND TELEPHONE CONDUIT SHALL BE PROVIDED AND INSTALLED PER UTILITY REQUIREMENTS
  - FOR COMPLETE INTERNAL WIRING AND ARRANGEMENT REFER TO DRAWINGS PROVIDED BY PPC MANUFACTURER.
  - ALL SERVICE EQUIPMENT AND INSTALLATIONS SHALL COMPLY WITH THE CURRENT EDITION(S) OF N.E.C., CALIFORNIA ELECTRICAL CODE, UTILITY COMPANY STANDARDS (GREENBOOK) AND LOCAL CODE REQUIREMENTS.
  - SUBCONTRACTOR SHALL INSTALL 36" OF FLEX CONDUIT WITH ALL CONDUIT FITTINGS (NUTS, REDUCING BUSHINGS, ELBOWS, COUPLINGS, ETC.) NECESSARY FOR CONNECTION TO THE EQUIPMENT
  - SUBCONTRACTOR SHALL PROVIDE ELECTRICAL SERVICE EQUIPMENT WITH FAULT CURRENT RATINGS GREATER THAN THE AVAILABLE FAULT CURRENT FROM THE POWER UTILITY
  - POWER, CONTROL AND EQUIPMENT GROUND WIRING IN TUBING OR CONDUIT, SHALL BE SINGLE CONDUCTOR (#14 AWG AND LARGER), 600V, OIL RESISTANT, THHN OR THHN-2, CLASS B STRANDED COPPER CABLE RATED FOR 90°C (WET AND DRY) OPERATION; LISTED OR LABELED FOR THE LOCATION AND RACEWAY SYSTEM USED
  - CUT, COIL AND TAPE A 10 FOOT PIGTAIL FROM END OF FLEX CONDUIT FOR TERMINATING BY CARRIER REP.
  - SUBCONTRACTOR SHALL FURNISH AND INSTALL A PIPE/UNISTRUT FRAME OR SUITABLE PEDESTAL OR WALL-MOUNTS FOR INSTALLATION OF PPC ENCLOSURE AND METER COMPONENTS. SUBCONTRACTOR SHALL FURNISH AND INSTALL SURGE PROTECTION DEVICES (BY ATLANTIC SCIENTIFIC; ZONE BARRIER SERIES; PART NO.90700 WITH MOUNTING DIN RAIL PART NO. 21607). BOND SURGE PROTECTION DEVICE RAIL TO THE ENCLOSURE WITH #6 AWG INSULATED WIRE. BOND ENCLOSURE TO THE SITE GROUND RING OR BAR WITH #2 AWG COPPER WIRE.
  - ALL CONDUCTORS SHALL BE THWN, COPPER 600V. 75° C; U.G. CONDUCTORS SHALL BE WET-RATED
  - ALL WORK TO COMPLY WITH TITLE 24 - CAL. CODE OF REGULATIONS, NFPA 70E (NEC 2020) AND OSHA TITLE 29.
  - REFER TO PANEL SCHEDULE(S) (2/-) AND ONE-LINE DIAGRAM (3/-) FOR CIRCUIT ARRANGEMENT & WIRING CONNECTION.
- MI = MECHANICAL INTERLOCK  
RU = RELAY TO MONITOR UTILITY POWER  
RGI = RELAY TO MONITOR GENERATOR #1 POWER

ELECTRICAL PLAN DIAGRAM NOTES:

- PLAN IS DIAGRAMMATIC, AND IS INTENDED TO CONVEY THE REQUIREMENTS OF THE SCOPE OF WORK. SEE EQUIPMENT LAYOUT IN CIVIL/ ARCHITECTURAL PAGES FOR ACTUAL EQUIPMENT LAYOUT/CONFIGURATION.
- ALL ELECTRICAL WORK SHALL BE PERFORMED IN ACCORDANCE WITH THE PROJECT SPECIFICATIONS AND ALL APPLICABLE LOCAL CODES.
- SERVICE TO AC PANEL SHALL BE 120/240VAC, 200A, 1-PHASE.
- SERVICE TO NEW RBS-6160 RF/POWER CABINET SHALL BE 120/240VAC, 100A, 1-PHASE.
- SERVICE TO EXISTING ACTIVE EQUIPMENT CABINET SHALL BE 120/240VAC, 60A, 1-PHASE.
- SUBCONTRACTOR SHALL COORDINATE WITH LANDLORD'S BUILDING MANAGER FOR ACCESS & WORK POLICIES.
- THE SUBCONTRACTOR SHALL VERIFY POWER CONDUIT ROUTING AND ALL RF CABLING REQUIRED PRIOR TO START OF CONSTRUCTION.
- ALL CONDUCTORS SHALL BE THWN, COPPER 600V. 75° C; U.G. CONDUCTORS SHALL BE WET-RATED
- REFER TO PANEL SCHEDULE(S) (2/-) AND ONE-LINE DIAGRAM (3/-) FOR CIRCUIT ARRANGEMENT & WIRING CONNECTION.
- REFER TO SITE GROUNDING SCHEMATIC (1/G-1) FOR NEW AND EXISTING EQUIPMENT, ANTENNA/CABLE GROUNDING STANDARDS.
- ALL WORK TO COMPLY WITH TITLE 24 - CAL. CODE OF REGULATIONS, NFPA 70E (CURRENT NEC) AND OSHA TITLE 29.

ONE-LINE DIAGRAM

3

NOTES:

- EXISTING AC PANEL REMOVED/REPLACED WITH NEW 200A 'PPC' CABINET W/ 200A AC SERVICE PANEL 'PPC'
- RBS 6102 BREAKER TO BE UPGRADED FROM 60A TO 80A

SITE NAME:		PPC PANEL 'A'		VOLTAGE:		120/240		V									
SF03171A ATHONTON #5		PPC PANEL 'A'		PHASE:		1											
PANEL DESIGNATION:		PPC PANEL 'A'		WIRE:		3											
				MAIN BREAKER:		200		AMP									
				BUSS RATING:		225		AMP									
				LOCATION:		SURFACE EXTERIOR											
CKT	LOAD DESCRIPTION	BREAKER AMPS	BREAKER POLES	BREAKER STATUS	SERVICE LOAD VA	USAGE FACTOR	PHASE A VA	PHASE B VA	PHASE C VA	USAGE FACTOR	SERVICE LOAD VA	BREAKER STATUS	BREAKER POLES	BREAKER AMPS	LOAD DESCRIPTION	CKT	
1	INTERNAL TVSS	30	2	ON	400	1.25	500	7200	7200	1.25	5760	ON	2	80	RBS 6102 (EXISTING)	2	
3					400	1.25	500	7200	7200	1.25	5760						4
5	INT. GFI RECEPTACLE	20	1	ON	180	1.25	225	10313	10313	1.25	8250	ON	2	125	6160 CABINET (NEW)	6	
7	LIGHT/FAN (EXISTING)	20	1	ON	480	1.25	600	10313	10313	1.25	8250						8
					PHASE A TOTAL VA		18238										
					PHASE B TOTAL VA		18613										
					TOTAL KVA		36.85										
					TOTAL AMPS		153.54										
POWER PROTECTION CABINET (INTI #: CAC-PEDI-PPC (MINI) CONTRACTOR TO LABEL WITH: CARRIER I.D. (T-MOBILE), PANEL I.D. (PPC PANEL 'A') FEED SOURCE (NEW METER), AND AC PANEL SERVICE RATING (200A, 120/240V, 1-PHASE, 3-WIRE)										NOTES:							
										1. CIRCUITS 9-30 ARE 'SPACE' W/ MFR. METAL TWIST-OFF COVER INTACT							
										2. ALL LOADS ARE CALCD AS LCL/MCL (DESIGN TO 100% CAPACITY-OK)							
										3. ALL UNUSED BREAKERS SHALL BE LABELED 'SPARE' & SWITCHED 'OFF'							

PANEL SCHEDULE

2

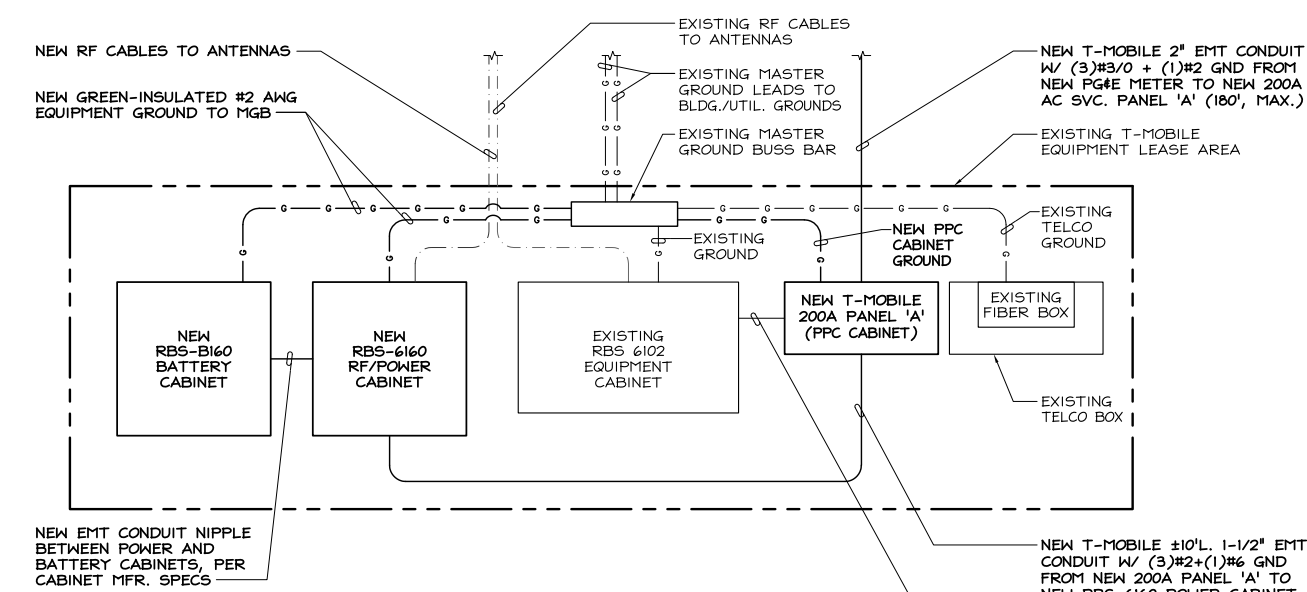

ELECTRICAL PLAN (DIAGRAMMATIC)

**T-Mobile**

1200 CONCORD AVE., SUITE 500  
CONCORD, CA 94520

**NETWORK CONNEX**

416 AVIATION BLVD, SUITE B  
SANTA ROSA, CA 95403

**ALLSTATES**  
ENGINEERING & SURVEYING

23675 BIRTCHEER DRIVE  
LAKE FOREST, CA 92630

PROJECT NO:	SF03171A
DRAWN BY:	SS
CHECKED BY:	KM

REV	DATE	DESCRIPTION	
I	11/22/2023	REVISE FRP SCREEN	RN
O	06/14/2023	100% CD'S FOR SUBMITTAL	MG
B	12/16/2022	95% FOR APPROVAL	MG
A	12/06/2022	90% CD'S FOR REVIEW	MG

REGISTERED PROFESSIONAL ENGINEER  
MUSAW ZALZALI  
71655  
CIVIL  
STATE OF CALIFORNIA

IT IS A VIOLATION OF LAW FOR ANY PERSON, UNLESS THEY ARE ACTING UNDER THE DIRECTION OF A LICENSED PROFESSIONAL ENGINEER, TO ALTER THIS DOCUMENT.

SF03171A  
ATHERTON #5  
201 4TH AVE  
REDWOOD CITY, CA 94063  
ANCHOR PROJECT

SHEET TITLE  
ELECTRICAL PLAN,  
PANEL SCHEDULES &  
ONE-LINE DIAGRAM

SHEET NUMBER  
**E-1**

1

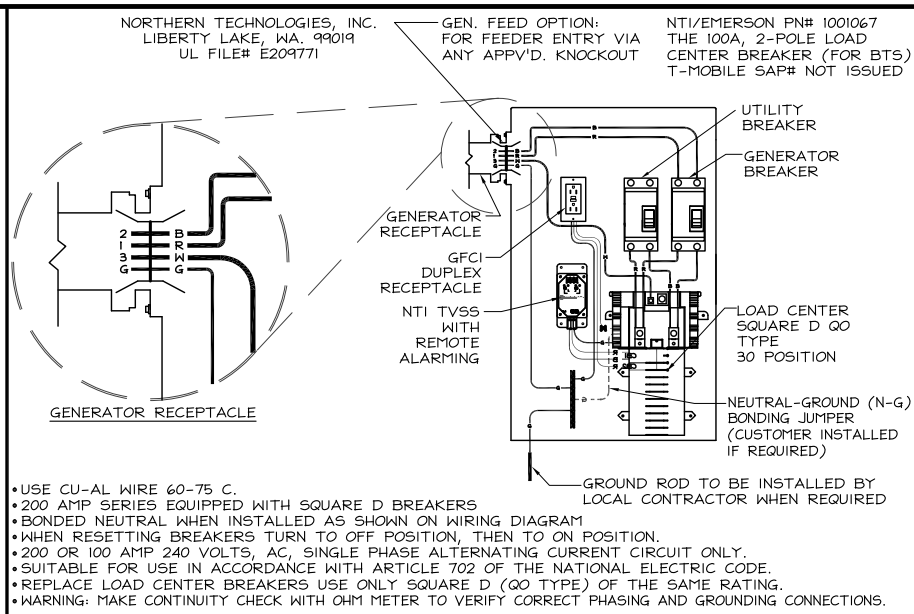
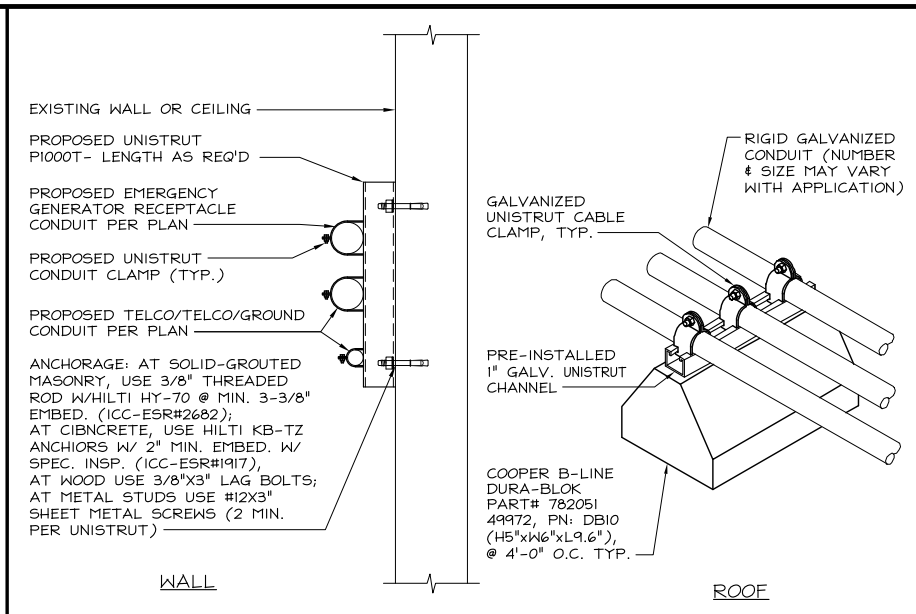
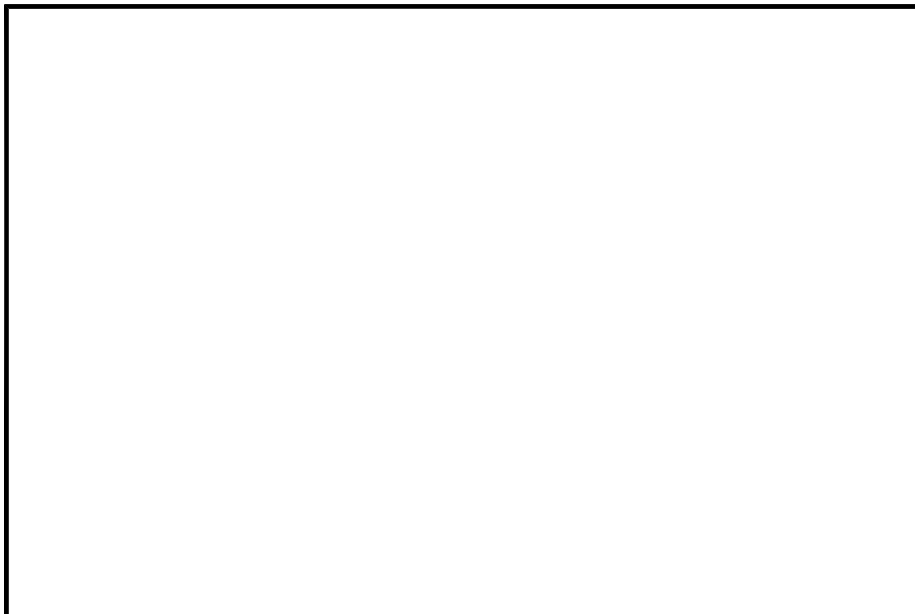

**T-Mobile**  
1200 CONCORD AVE., SUITE 500  
CONCORD, CA 94520

**NETWORK CONNEX**  
416 AVIATION BLVD, SUITE B  
SANTA ROSA, CA 95403

**ALLSTATES**  
ENGINEERING & SURVEYING  
23675 BIRTCHEER DRIVE  
LAKE FOREST, CA 92630

**NOT USED** 24"x36" SCALE: NTS 11"x17" SCALE: NTS **9**

**CONDUIT MOUNTING** 24"x36" SCALE: NTS 11"x17" SCALE: NTS **6**

**PPC CABINET LAYOUT/WIRING** 24"x36" SCALE: NTS 11"x17" SCALE: NTS **3**

PROJECT NO: SF03171A  
DRAWN BY: SS  
CHECKED BY: KM

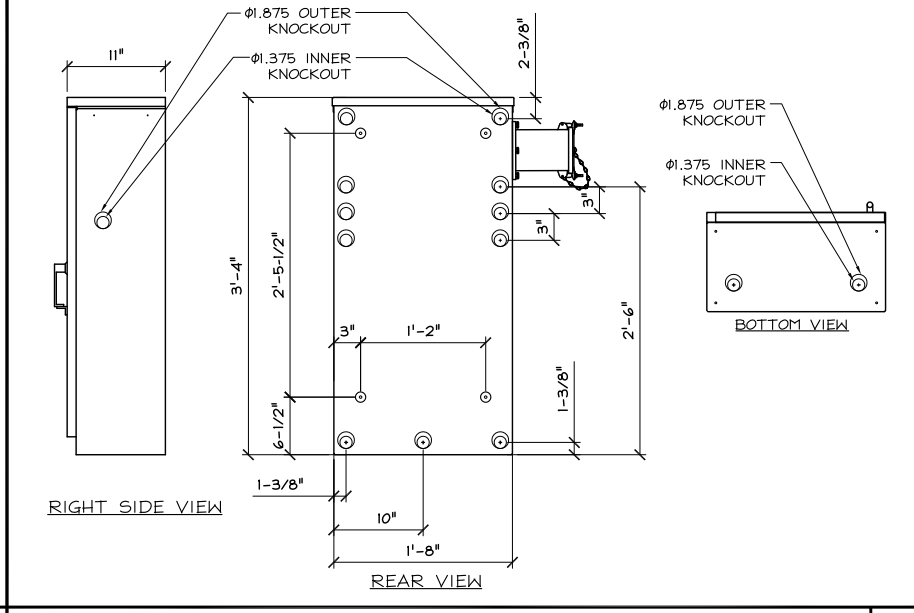
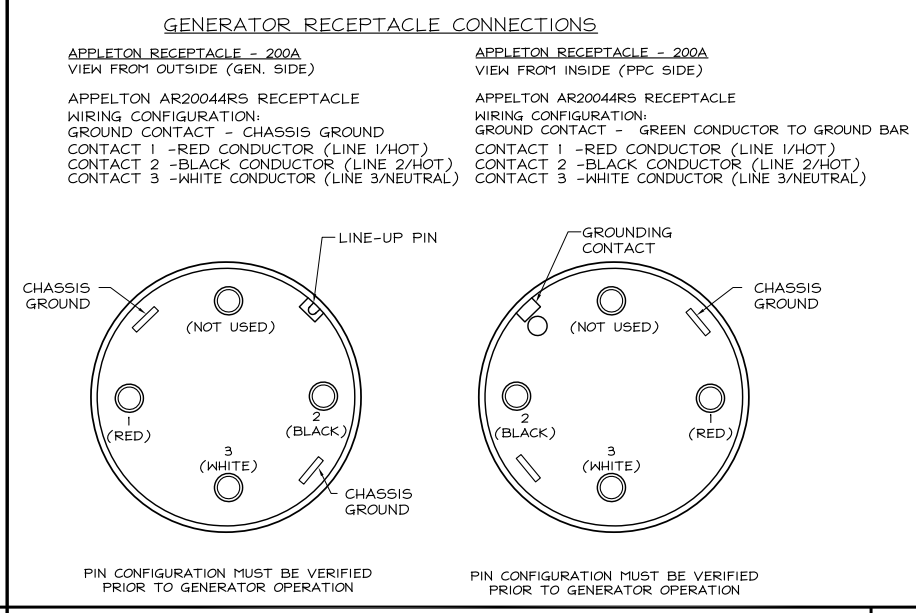

REV	DATE	DESCRIPTION	
I	11/22/2023	REVISE FRP SCREEN	RN
O	06/14/2023	100% CD'S FOR SUBMITTAL	MG
B	12/16/2022	95% FOR APPROVAL	MG
A	12/06/2022	90% CD'S FOR REVIEW	MG

**NOT USED** 24"x36" SCALE: NTS 11"x17" SCALE: NTS **8**

**RECEPTACLE PIN-OUT DIAGRAM** 24"x36" SCALE: NTS 11"x17" SCALE: NTS **5**

**PPC CABINET (HOLE LAYOUT)** 24"x36" SCALE: NTS 11"x17" SCALE: NTS **2**

REGISTERED PROFESSIONAL ENGINEER  
MUSAW ZALZALI  
71655  
CIVIL  
STATE OF CALIFORNIA

IT IS A VIOLATION OF LAW FOR ANY PERSON, UNLESS THEY ARE ACTING UNDER THE DIRECTION OF A LICENSED PROFESSIONAL ENGINEER, TO ALTER THIS DOCUMENT.

**Meter Main Load Center - With Safety Socket Bypass**

200 Amp - 10K AIC

**SPECIFICATIONS**  
MFG: B-LINE BY EATON  
MODEL: 224 MTB  
HEIGHT: 30 IN  
WIDTH: 14 IN  
DEPTH: 6 IN

**Application**  
• Combination meter/main with safety socket (test block)  
• Receive ANSI C12.10 watt-hour meters  
• Factory installed breaker  
• Surface mount

**Construction**  
• Ring type  
• NEMA Type 3R  
• ANSI 61 gray painted finish  
• Aluminum snap ring included

**Standards**  
• UL 67 Listed  
• ANSI C12.7  
• EUSERC 305A

**Accessories**  
• 5th Jaw Kit - 50371  
• Bussed Gutters  
• AW Hubs

U224 MTB (open)

Part/UPC Number	Catalog Number	Amp Rating	Jaws	Service Type	Access	Voltage	Main Breaker AIC	Main	Bypass
78205159125	U224 MTB	200	4	10/3W OH/UG		120/240	10K (1) 200A	2P	TB

Part/UPC Number	Catalog Number	Line Load	Connections	Neutral	Height	Overall Dimensions Width	Depth	Top Provision Layout	Knockout
78205159125	U224 MTB	#6 - 250 MCM	MCB #6 - 250 MCM		30"	22"	6"	AW Hub Fig. 2	

MCB - Main Circuit Breaker

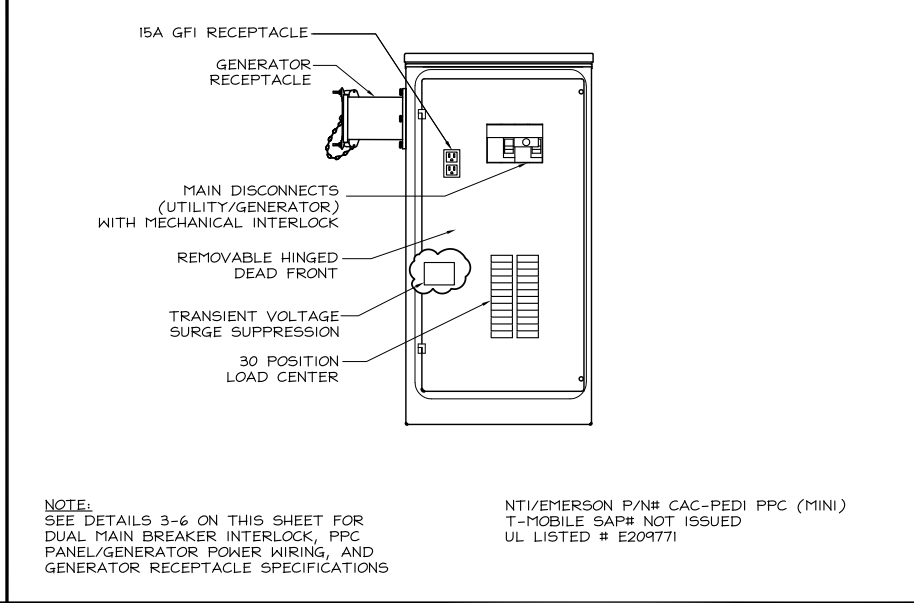
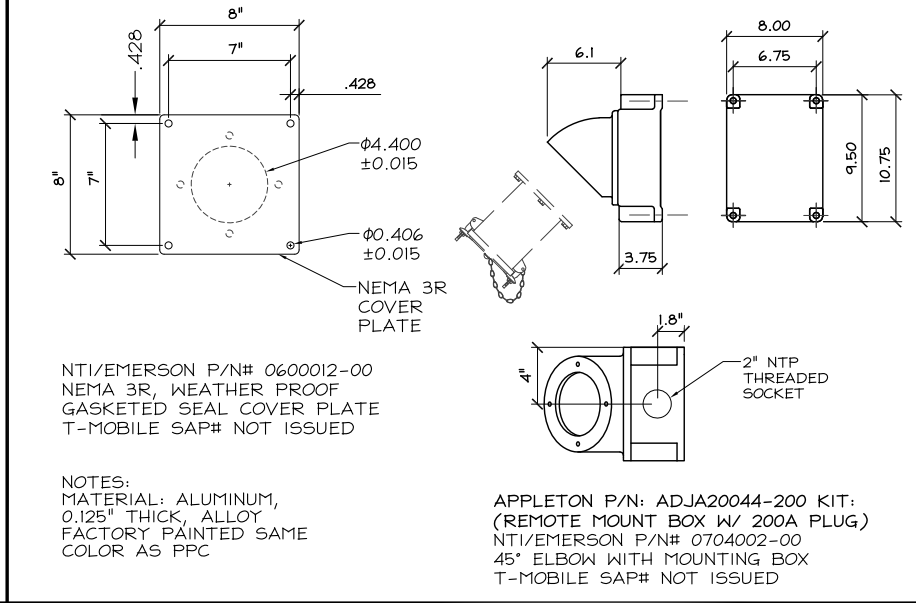

SF03171A  
ATHERTON #5  
201 4TH AVE  
REDWOOD CITY, CA 94063  
ANCHOR PROJECT

SHEET TITLE  
**ELECTRICAL DETAILS**

SHEET NUMBER  
**E-2**

**METER LOAD CENTER SPECIFICATIONS** 24"x36" SCALE: NTS 11"x17" SCALE: NTS **7**

**COVER PLATE & REMOTE MOUNT BOX** 24"x36" SCALE: NTS 11"x17" SCALE: NTS **4**

**PPC CABINET (PPC PANEL 'A')** 24"x36" SCALE: NTS 11"x17" SCALE: NTS **1**



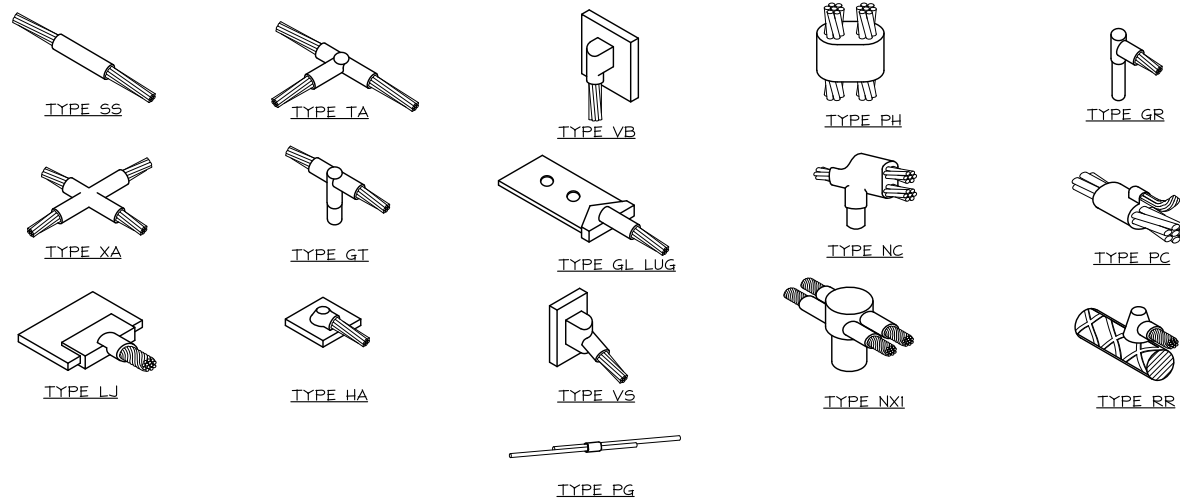

**TYPICAL CADWELD TYPES**

24"x36" SCALE: NTS  
11"x17" SCALE: NTS

**5**

**GROUNDING NOTES**

24"x36" SCALE: NTS  
11"x17" SCALE: NTS

**2**

1. ALL DETAILS ARE SHOWN IN GENERAL TERMS. ACTUAL GROUNDING INSTALLATION AND CONSTRUCTION MAY VARY DUE TO SITE SPECIFIC CONDITIONS.
2. GROUND ALL ANTENNA BASES, FRAMES, CABLE RUNS, AND OTHER METALLIC COMPONENTS USING #2 GROUND WIRES AND CONNECT TO SURFACE MOUNTED GROUND BUS BARS AS SHOWN. FOLLOW ANTENNA AND BTS MANUFACTURER'S PRACTICES FOR GROUNDING REQUIREMENTS. GROUND COAX SHIELD AT BOTH ENDS USING MANUFACTURER'S PRACTICES. ALL UNDERGROUND WATER PIPES, METAL CONDUITS AND GROUNDS THAT ARE A PART OF THIS SYSTEM SHALL BE BONDED TOGETHER.
3. ALL GROUND CONNECTIONS SHALL BE #2 AWG U.N.O. ALL WIRES SHALL BE COPPER THIN/TINNED. ALL GROUND WIRE SHALL BE SOLID TIN COATED OR STRANDED GREEN INSULATED WIRE.
4. CONTRACTOR TO VERIFY AND TEST GROUND TO SOURCE, 5 OHMS MAXIMUM. PROVIDE SUPPLEMENT GROUNDING RODS AS REQUIRED TO ACHIEVE SPECIFIED OHMS READING. GROUNDING AND OTHER OPTIONAL TESTING WILL BE WITNESSED BY THE T-MOBILE REPRESENTATIVE.
5. NOTIFY ARCHITECT/ENGINEER IF THERE ARE ANY DIFFICULTIES INSTALLING GROUNDING SYSTEM DUE TO SITE SOIL CONDITIONS.
6. BARE GROUNDING CONDUCTOR SHALL BE HARD DRAWN TINNED COPPER SIZES AS NOTED ON PLAN.
7. ALL HORIZONTALLY RUN GROUNDING CONDUCTORS SHALL BE INSTALLED MINIMUM 12" BELOW GRADE/FROST-LINE IN TRENCH, U.N.O., AND BACK FILL SHALL BE COMPACTED AS REQUIRED BY ARCHITECT.
8. ALL GROUND CONDUCTORS SHALL BE RUN AS STRAIGHT AND SHORT AS POSSIBLE, WITH A MINIMUM 12" BENDING RADIUS NOT LESS THAN 90 DEGREES.
9. ALL SUPPORT STRUCTURES, CABLE CHANNEL WAYS OR WIRE GUIDES SHALL BE BONDED TO GROUND SYSTEM AT A POINT NEAREST THE MAIN GROUNDING BUS "MGB" (OR DIRECTLY TO GROUND-RING).
10. ACCEPTABLE CONNECTIONS FOR GROUNDING SYSTEM SHALL BE:
  - a. BURNDY, HY-GRADE U.L. LISTED CONNECTORS FOR INDOOR USE OR AS APPROVED BY T-MOBILE PROJECT MANAGER.
  - b. CADWELD, EXOTHERMIC WELDS (WELDED CONNECTIONS).
  - c. TWO (2) HOLE TINNED COPPER COMPRESSION (LONG BARREL) FITTINGS (BUS BAR CONNECTIONS).
11. ALL CRIMPED CONNECTIONS SHALL HAVE EMBOSSED MANUFACTURER'S DIEMARK VISIBLE AT THE CRIMP (RESULTING FROM USE OF PROPER CRIMPING DEVICES).
12. PRIOR TO ANY LUG-BUSSBAR CONNECTIONS, THE BUSSBAR SHALL BE CLEANED BY USE OF "SCOTCH-BRITE" OR PLAIN STEEL WOOL AS TO REMOVE ALL SURFACE OXIDATION AND CONTAMINANTS. A COATING OF "NO-OX-ID" SHALL BE APPLIED TO THE CONNECTION SURFACES.
13. ALL CONNECTION HARDWARE SHALL BE TYPE 316 SS (NOT ATTRACTED TO MAGNETS).
14. THE GROUND RING SHALL BE INSTALLED 24" MINIMUM BEYOND ANY BUILDING DRIP LINE.
15. ELECTRICAL SERVICE EQUIPMENT GROUNDING SHALL COMPLY WITH NEC, ARTICLE 250-82 AND SHALL BOND ALL EXISTING AND NEW GROUNDING ELECTRODES. NEW GROUNDING ELECTRODE SHALL INCLUDE BUT NOT LIMITED TO GROUND RODS, GROUND RING IF SERVICE IS WITHIN THE RADIO EQUIPMENT LOCATION, BUILDING STEEL IF APPLICABLE, COLD WATER CONNECTIONS MUST BE MADE ON THE STREET SIDE OF MAIN SHUT-OFF VALVE.



PROJECT NO:	SF03171A
DRAWN BY:	SS
CHECKED BY:	KM

REV	DATE	DESCRIPTION	
I	11/22/2023	REVISE FRP SCREEN	RN
O	06/14/2023	100% CD'S FOR SUBMITTAL	MG
B	12/16/2022	95% FOR APPROVAL	MG
A	12/06/2022	90% CD'S FOR REVIEW	MG

REGISTERED PROFESSIONAL ENGINEER  
MUSAW ZALZALI  
71655  
CIVIL  
STATE OF CALIFORNIA

IT IS A VIOLATION OF LAW FOR ANY PERSON, UNLESS THEY ARE ACTING UNDER THE DIRECTION OF A LICENSED PROFESSIONAL ENGINEER, TO ALTER THIS DOCUMENT.

SF03171A  
ATHERTON #5  
201 4TH AVE  
REDWOOD CITY, CA 94063  
ANCHOR PROJECT

SHEET TITLE  
GROUNDING SCHEMATIC,  
NOTES & DETAILS

SHEET NUMBER  
**G-1**

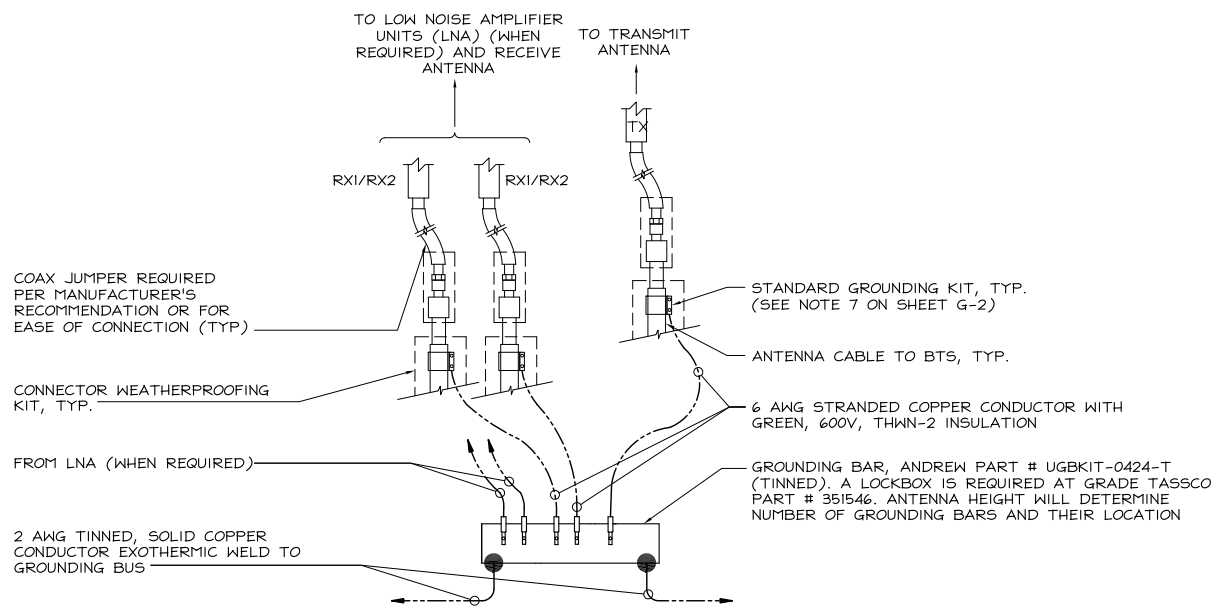

**GROUNDING BAR CONNECTION**

24"x36" SCALE: NTS  
11"x17" SCALE: NTS

**4**

- NOTES:
1. "DOUBLING UP" OR "STACKING" OF CONNECTIONS IS NOT PERMITTED.
  2. OXIDE INHIBITING COMPOUND TO BE USED AT ALL LOCATIONS AND TO BE APPLIED PRIOR TO ADDING HARDWARE.

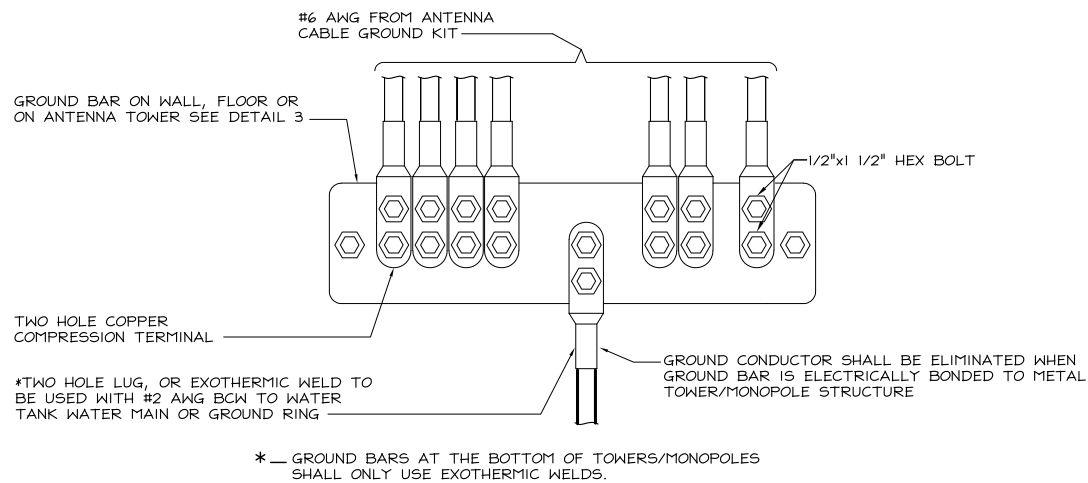

**WIRE TO GROUND BAR CONNECTION**

24"x36" SCALE: NTS  
11"x17" SCALE: NTS

**3**

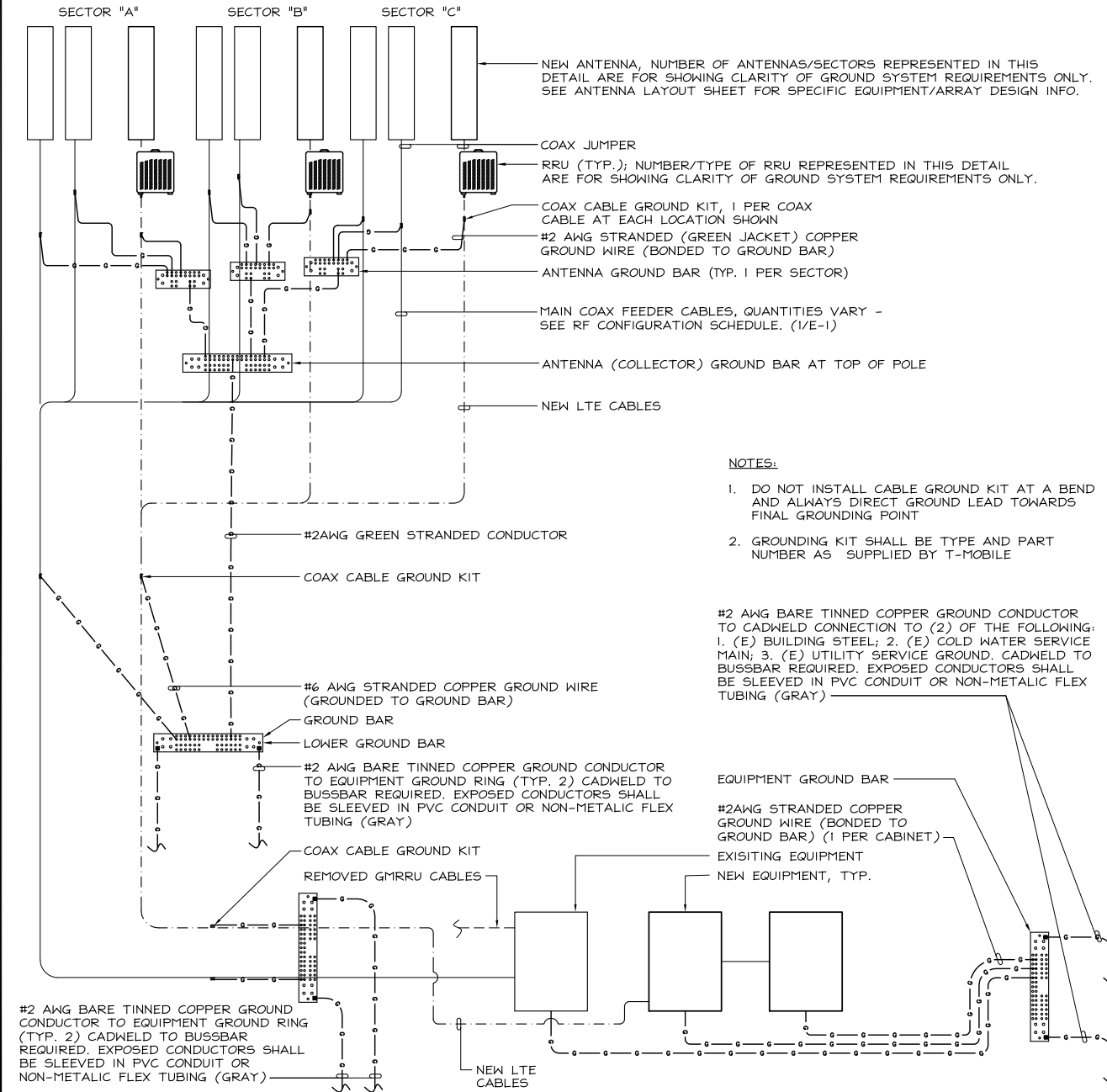

**COAX CABLE GROUNDING SCHEMATIC DIAGRAM**

24"x36" SCALE: NTS  
11"x17" SCALE: NTS

**1**

**T-Mobile**  
 1200 CONCORD AVE., SUITE 500  
 CONCORD, CA 94520

**NETWORK CONNEX**  
 416 AVIATION BLVD, SUITE B  
 SANTA ROSA, CA 95403

**ALLSTATES**  
 ENGINEERING & SURVEYING  
 23675 BIRCHER DRIVE  
 LAKE FOREST, CA 92630

PROJECT NO: SF03171A  
 DRAWN BY: SS  
 CHECKED BY: KM

REV	DATE	DESCRIPTION	
I	11/22/2023	REVISE FRP SCREEN	RN
O	06/14/2023	100% CD'S FOR SUBMITTAL	MG
B	12/16/2022	95% FOR APPROVAL	MG
A	12/16/2022	90% CD'S FOR REVIEW	MG

  
 REGISTERED PROFESSIONAL ENGINEER  
 NASSIM ZALZALI  
 71655  
 CIVIL  
 STATE OF CALIFORNIA  
*N. Zalzali*

IT IS A VIOLATION OF LAW FOR ANY PERSON, UNLESS THEY ARE ACTING UNDER THE DIRECTION OF A LICENSED PROFESSIONAL ENGINEER, TO ALTER THIS DOCUMENT.

SF03171A  
 ATHON #5  
 201 4TH AVE  
 REDWOOD CITY, CA 94063  
 ANCHOR PROJECT

SHEET TITLE  
**GROUNDING DETAILS**

SHEET NUMBER  
**G-2**

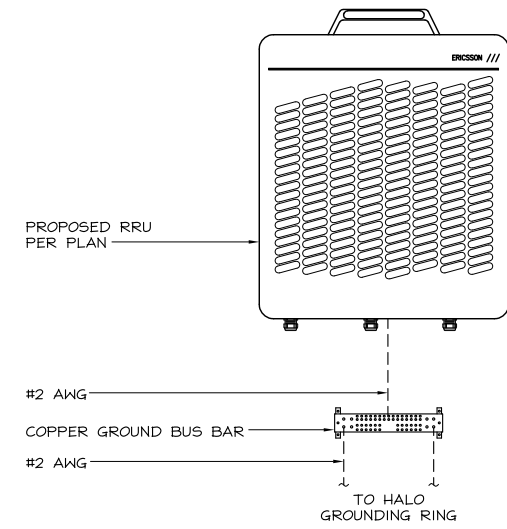

**6 RRU GROUNDING DETAIL**

24"x36" SCALE: NTS  
 11"x17" SCALE: NTS

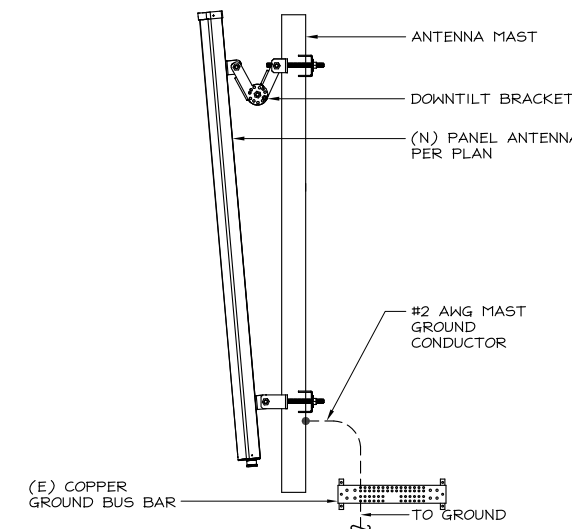

**5 ANTENNA/RRU GROUNDING**

24"x36" SCALE: NTS  
 11"x17" SCALE: NTS

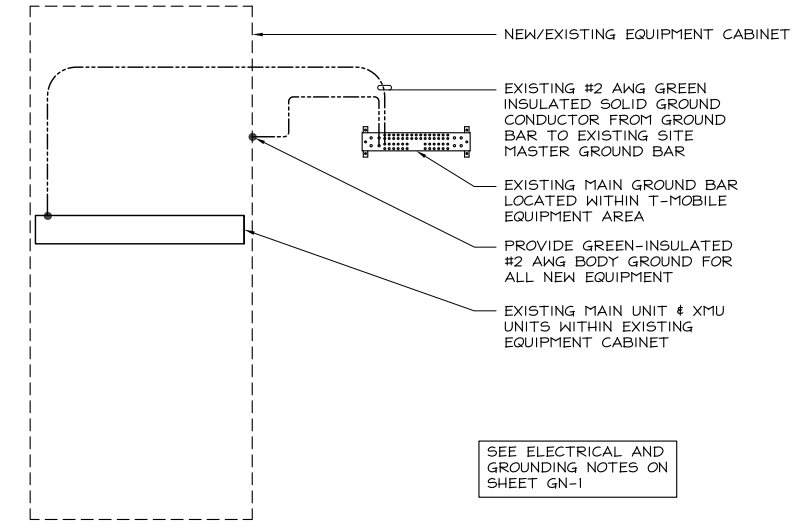

**4 EQUIPMENT GROUNDING DETAIL**

24"x36" SCALE: NTS  
 11"x17" SCALE: NTS

**NOT USED**

24"x36" SCALE: NTS  
 11"x17" SCALE: NTS

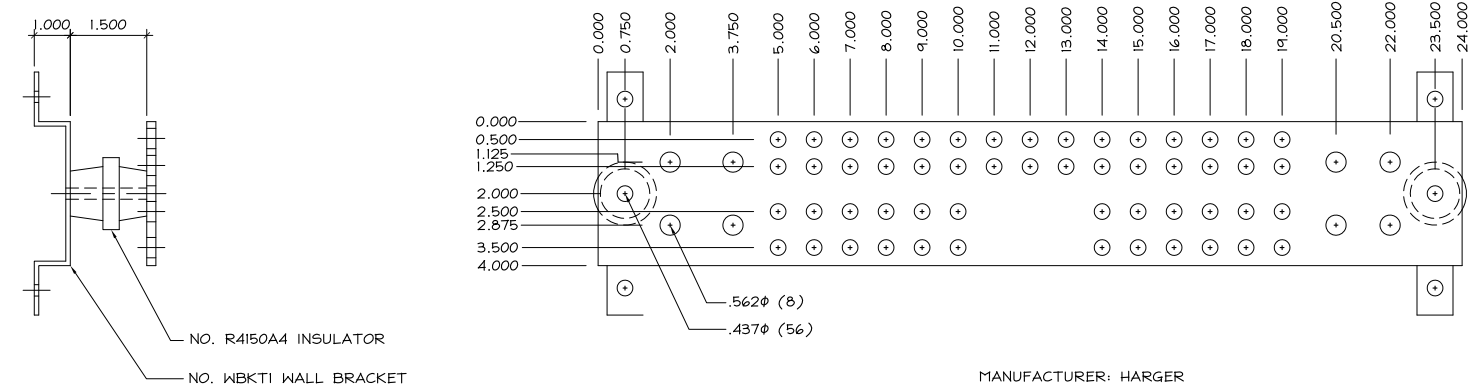

**24" GROUND BAR**

24"x36" SCALE: NTS  
 11"x17" SCALE: NTS

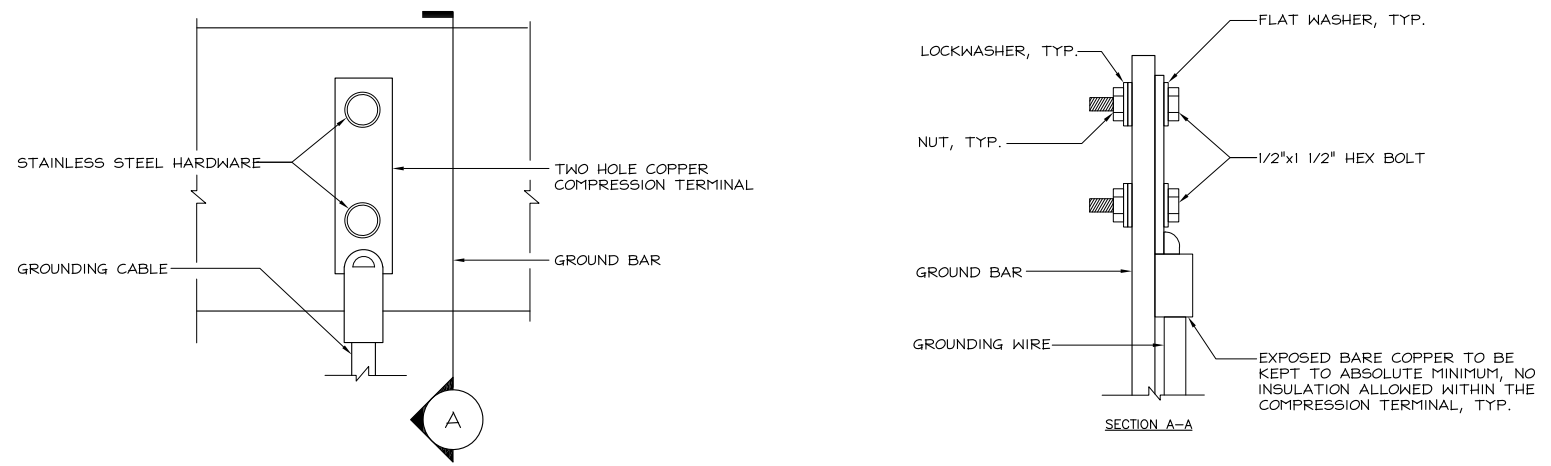

**TYPICAL GROUND BAR CONNECTION**

24"x36" SCALE: NTS  
 11"x17" SCALE: NTS

- NOTES:
- "DOUBLING UP" OR "STACKING" OF CONNECTIONS IS NOT PERMITTED.
  - OXIDE INHIBITING COMPOUND TO BE USED AT ALL LOCATIONS AND TO BE APPLIED PRIOR TO ADDING HARDWARE.

**3**

24"x36" SCALE: NTS  
 11"x17" SCALE: NTS



**COUNTY OF SAN MATEO - PLANNING AND BUILDING DEPARTMENT**

**ATTACHMENT D**

# Radio Frequency – Electromagnetic Energy (RF-EME) Compliance Report

T-Mobile Proposed Facility

Site ID: SF03171A

SF171 4th Ave. Apt.

201 4th Avenue, Redwood City, California 94063

December 21, 2023

EBI Project Number: 6223004308

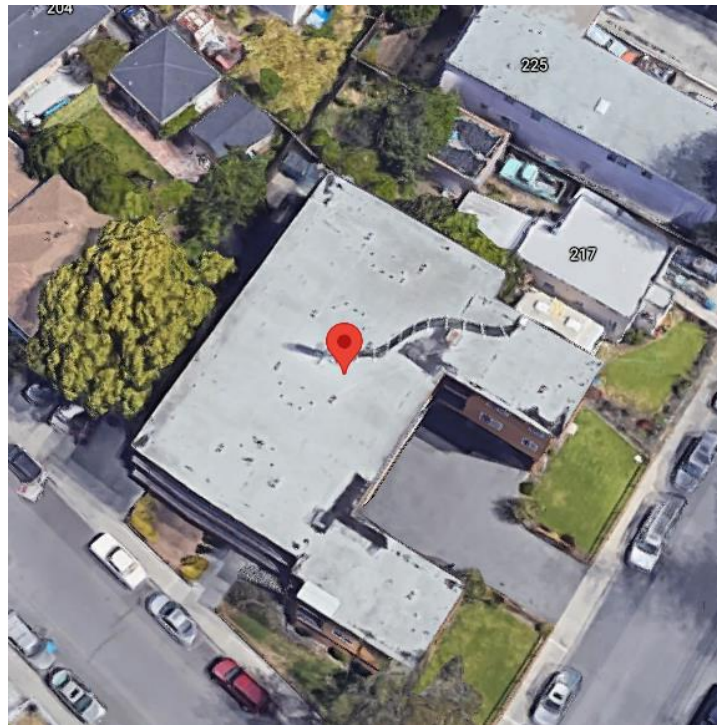

**Report Findings:** The proposed site will be compliant with the installation of the mitigation measures described in Section 8.0.

Prepared by:



# TABLE OF CONTENTS

## Contents

<b>1.0</b>	<b>Executive Summary .....</b>	<b>3</b>
<b>2.0</b>	<b>MPE Calculations.....</b>	<b>4</b>
<b>3.0</b>	<b>T-Mobile Antenna Inventory .....</b>	<b>5</b>
<b>4.0</b>	<b>FCC Rules and Regulations and Guidelines from OET 65.....</b>	<b>6</b>
<b>5.0</b>	<b>Safety Recommendations .....</b>	<b>8</b>
<b>6.0</b>	<b>FCC Limits .....</b>	<b>9</b>
<b>7.0</b>	<b>MPE Analysis.....</b>	<b>10</b>
<b>8.0</b>	<b>Mitigation Diagram .....</b>	<b>13</b>
<b>9.0</b>	<b>Summary .....</b>	<b>14</b>
<b>10.0</b>	<b>Certification.....</b>	<b>15</b>

## **I.0 Executive Summary**

EnviroBusiness Inc. (dba EBI Consulting) has been contracted by T-Mobile to conduct radio frequency electromagnetic (RF-EME) modeling for T-Mobile Site SF03171A located at 201 4th Avenue in Redwood City, California to determine RF-EME exposure levels from proposed T-Mobile wireless communications equipment at this site. As described in detail in Appendix B of this report, the Federal Communications Commission (FCC) has developed Maximum Permissible Exposure (MPE) Limits for general public exposures and occupational exposures. This report summarizes the results of RF-EME modeling in relation to relevant FCC RF-EME compliance standards for limiting human exposure to RF-EME fields. This report contains a detailed summary of the RF EME analysis for the site.

This document addresses the compliance of T-Mobile's proposed transmitting facilities independently at the site.

While access to this site is considered controlled, the MPE analysis considers exposures with respect to both controlled (Occupational) and uncontrolled (General Public) limits.

The FCC's General Public or Occupational Limit is expressed as a percentage and each limit is reached at values meeting or exceeding 100% of the representative limit.

The Maximum Emissions Value is 459.4700% of the FCC's general public limit (91.8940% of the FCC's occupational limit) at the main roof level. The proposed site will be compliant with Federal regulations regarding (radio frequency) RF Emissions with the installation of the mitigation measures.

At the nearest walking/working surfaces to the T-Mobile antennas on the main roof level, the maximum power density generated by the T-Mobile antennas is approximately 459.4700% of the FCC's general public limit (91.8940% of the FCC's occupational limit). Based on worst-case predictive modeling, there are no areas at ground level related to the proposed antennas that exceed the FCC's occupational or general public exposure limits at this site. At ground level, the maximum power density generated by the antennas is approximately 1.8200% of the FCC's general public limit (0.3640% of the FCC's occupational limit).

Based on worst-case predictive modeling, the worst-case emitted power density may exceed the FCC's general public limit within approximately 19 feet of T-Mobile's proposed antennas at the main roof level. Modeling also indicates that the worst-case emitted power density will not exceed the FCC's occupational limit at the main roof level. These predicted exposures are identified at the main roof level in the horizontal transmission path of the antennas. Only those accessing this main roof level or those elevated to this plane will encounter the exposures identified above.

Signage is recommended at the site as presented in the Mitigation Diagram. Posting of the signage brings the site into compliance with FCC rules and regulations.



## 2.0 MPE Calculations

Calculations were completed for the proposed T-Mobile Wireless antenna rooftop facility located at 201 4th Avenue in Redwood City, California using the equipment information listed below. All calculations were performed per the specifications under FCC Office of Engineering & Technology (OET) Bulletin 65, "Evaluating Compliance with FCC Guidelines for Human Exposure to Radiofrequency Electromagnetic Fields" (OET-65). Because of the short wavelength of PCS services, the antennas require line-of-site paths for good propagation and are typically installed a distance above ground level. Antennas are constructed to concentrate energy towards the horizon, with as little energy as possible scattered towards the ground or the sky. This design, combined with the low power of PCS facilities, generally results in no possibility for exposure to approach Maximum Permissible Exposure (MPE) levels, with the exception of areas in the immediate vicinity of the antennas.

In accordance with T-Mobile's RF Exposure policy, EBI performed theoretical modeling using RoofMaster™ software to estimate the worst-case power density at the site rooftop-level resulting from operation of the antennas. Using the computational methods set forth in OET-65, RoofMaster™ calculates power density in a scalable grid based on the contributions of all RF sources characterized in the study scenario. At each grid location, the cumulative power density is expressed as a percentage of the FCC limits. Manufacturer antenna pattern data is utilized in these calculations. RoofMaster™ models consist of the Far Field model as specified in OET-65 and an implementation of the OET-65 Cylindrical Model (Sula9). The models utilize several operational specifications for different types of antennas to produce a plot of spatially-averaged power densities that can be expressed as a percentage of the applicable exposure limit.

For this report, EBI utilized antenna and power data provided by T-Mobile and compared the resultant worst-case MPE levels to the FCC's general public/uncontrolled exposure limits outlined in OET Bulletin 65. EBI has performed theoretical worst-case modeling using RoofMaster™ to estimate the maximum potential power density from each proposed antenna based on worst-case assumptions for the number of antennas and power. All radios at the proposed installation were considered to be running at full power and were uncombined in their RF transmission paths per carrier prescribed configuration. Modeling for AIR and similar SON antennas is based on worst-case assumptions that include all beams transmitting simultaneously. This is to ensure that all areas of potential concern are taken into consideration. As such, the results are conservative in nature and reflect potentially higher levels of RF emissions compared to actual on-air conditions. It is recommended that areas of concern be confirmed with onsite measurements once the facility is active.

The assumptions used in the modeling are based upon information provided by T-Mobile in the supplied drawings.

There are no collocated carriers on the rooftop.

The data for all T-Mobile antennas used in this analysis is shown in Section 3.0. Actual antenna gains for each antenna were used per manufacturer's specifications. All calculations were done with respect to the FCC's general public/uncontrolled threshold limits.

Based on information provided by T-Mobile, access to this site is considered controlled.

### 3.0 T-Mobile Antenna Inventory

Carrier	Sector	Antenna Number	Technology	Antenna Make	Antenna Model	Azimuth (°)	Centerline Height (feet) Above Nearest Walking Surface	Centerline Height (feet) Above Ground Level
T-Mobile	A	1	NR	RFS	SON_APXVAALL24_43-U-NA20 02DT-12DT 600	15	5	32.00
T-Mobile	A	1	LTE	RFS	SON_APXVAALL24_43-U-NA20 02DT-12DT 700	15	5	32.00
T-Mobile	A	1	LTE	RFS	SON_APXVAALL24_43-U-NA20 02DT-12DT 1900	15	5	32.00
T-Mobile	A	1	NR	RFS	SON_APXVAALL24_43-U-NA20 02DT-12DT 1900	15	5	32.00
T-Mobile	A	1	LTE	RFS	SON_APXVAALL24_43-U-NA20 02DT-12DT 2100	15	5	32.00
T-Mobile	A	2	NR	ERICSSON	SON_AIR6419 B41 NR TB 02.09.21 2500 TMO	15	5	32.00
T-Mobile	A	2	NR	ERICSSON	SON_AIR6419 B41 NR BrM 2500 TMO	15	5	32.00
T-Mobile	B	3	NR	RFS	SON_APXVAALL24_43-U-NA20 02DT-12DT 600	135	5	32.00
T-Mobile	B	3	LTE	RFS	SON_APXVAALL24_43-U-NA20 02DT-12DT 700	135	5	32.00
T-Mobile	B	3	LTE	RFS	SON_APXVAALL24_43-U-NA20 02DT-12DT 1900	135	5	32.00
T-Mobile	B	3	NR	RFS	SON_APXVAALL24_43-U-NA20 02DT-12DT 1900	135	5	32.00
T-Mobile	B	3	LTE	RFS	SON_APXVAALL24_43-U-NA20 02DT-12DT 2100	135	5	32.00
T-Mobile	B	4	NR	ERICSSON	SON_AIR6419 B41 NR TB 02.09.21 2500 TMO	135	5	32.00
T-Mobile	B	4	NR	ERICSSON	SON_AIR6419 B41 NR BrM 2500 TMO	135	5	32.00
T-Mobile	C	5	NR	RFS	SON_APXVAALL24_43-U-NA20 02DT-12DT 600	255	5	32.00
T-Mobile	C	5	LTE	RFS	SON_APXVAALL24_43-U-NA20 02DT-12DT 700	255	5	32.00
T-Mobile	C	5	LTE	RFS	SON_APXVAALL24_43-U-NA20 02DT-12DT 1900	255	5	32.00
T-Mobile	C	5	NR	RFS	SON_APXVAALL24_43-U-NA20 02DT-12DT 1900	255	5	32.00
T-Mobile	C	5	LTE	RFS	SON_APXVAALL24_43-U-NA20 02DT-12DT 2100	255	5	32.00
T-Mobile	C	6	NR	ERICSSON	SON_AIR6419 B41 NR TB 02.09.21 2500 TMO	255	5	32.00
T-Mobile	C	6	NR	ERICSSON	SON_AIR6419 B41 NR BrM 2500 TMO	255	5	32.00

## 4.0 FCC Rules and Regulations and Guidelines from OET 65

When considering the contributions to field strength or power density from other RF sources, care should be taken to ensure that such variables as reflection and re-radiation are considered. In cases involving very complex sites, predictions of RF fields may not be possible, and a measurement survey may be necessary. The process for determining compliance for other situations can be similarly accomplished using the techniques described in this section and in Supplement A to this bulletin that deals with radio and television broadcast operations. However, as mentioned above, measurements may be necessary at very complex sites.

In the simple example shown in the below diagram, it is desired to determine the power density at a given location  $X$  meters from the base of a tower on which are mounted two antennas. One antenna is a CMRS antenna with several channels, and the other is an FM broadcast antenna. The system parameters that must be known are the total ERP for each antenna and the operating frequencies (to determine which MPE limits apply). The heights above ground level for each antenna,  $H1$  and  $H2$ , must be known in order to calculate the distances,  $R1$  and  $R2$ , from the antennas to the point of interest.

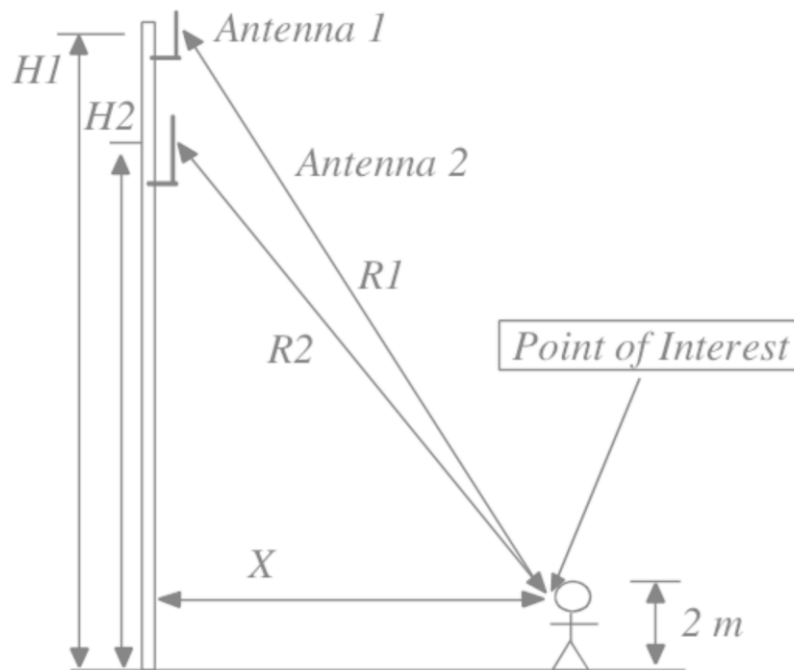

This summarizes the policies, guidelines, and requirements that were adopted by the FCC on August 1, 1996, amending Part 1 of Title 47 of the Code of Federal Regulations, and further amended by action of the Commission on August 25, 1997 (see 47 CFR Sections 1.1307(b), 1.1310, 2.1091 and 2.1093, as amended from FCC "OET Bulletin 65"). Commission actions granting construction permits, licenses to transmit or renewals thereof, equipment authorizations or modifications in existing facilities, require the preparation of an Environmental Assessment (EA), as described in 47 CFR Section 1.1311, if the particular facility, operation or transmitter would cause human exposure to levels of radiofrequency (RF) electromagnetic fields in excess of these limits. For exact language, see the relevant FCC rule sections.

The FCC-adopted limits for Maximum Permissible Exposure (MPE) are generally based on recommended exposure guidelines published by the National Council on Radiation Protection and Measurements (NCRP) in "Biological Effects and Exposure Criteria for Radiofrequency Electromagnetic Fields," NCRP Report No. 86, Sections 17.4.1, 17.4.1.1, 17.4.2 and 17.4.3. Copyright NCRP, 1986, Bethesda, Maryland 20814. In the frequency range from 100 MHz to 1500 MHz, exposure limits for field strength and power density are also generally based on the MPE limits found in Section 4.1 of, "IEEE Standard for Safety Levels with Respect to Human Exposure to Radio Frequency Electromagnetic Fields, 3 kHz to 300 GHz," ANSI/IEEE C95.1-1992, Copyright 1992 by the Institute of Electrical and Electronics Engineers, Inc., New York, New York 10017, and approved for use as an American National Standard by the American National Standards Institute (ANSI). The exposure guidelines are based on thresholds for known adverse effects and they incorporate a significant margin of safety. The federal health and safety agencies such as: the Environmental Protection Agency ("EPA"), the Food and Drug Administration ("FDA"), the National Institute on Occupational Safety and Health ("NIOSH") and the Occupational Safety and Health Administration ("OSHA") have also been actively involved in monitoring and investigating issues related to RF exposure.

The formulas used in RoofMaster™ for calculating Power density are based on FCC "OET Bulletin 65", Section 2: PREDICTION METHODS, August 1997, Edition 97-01. Power density is converted to Maximum Permissible Exposure Limits (MPE Limits) based on Limits of General Population/Uncontrolled Exposure and Limits of Occupational/Controlled Exposure presented in the following table generated from Appendix A of "OET Bulletin 65."

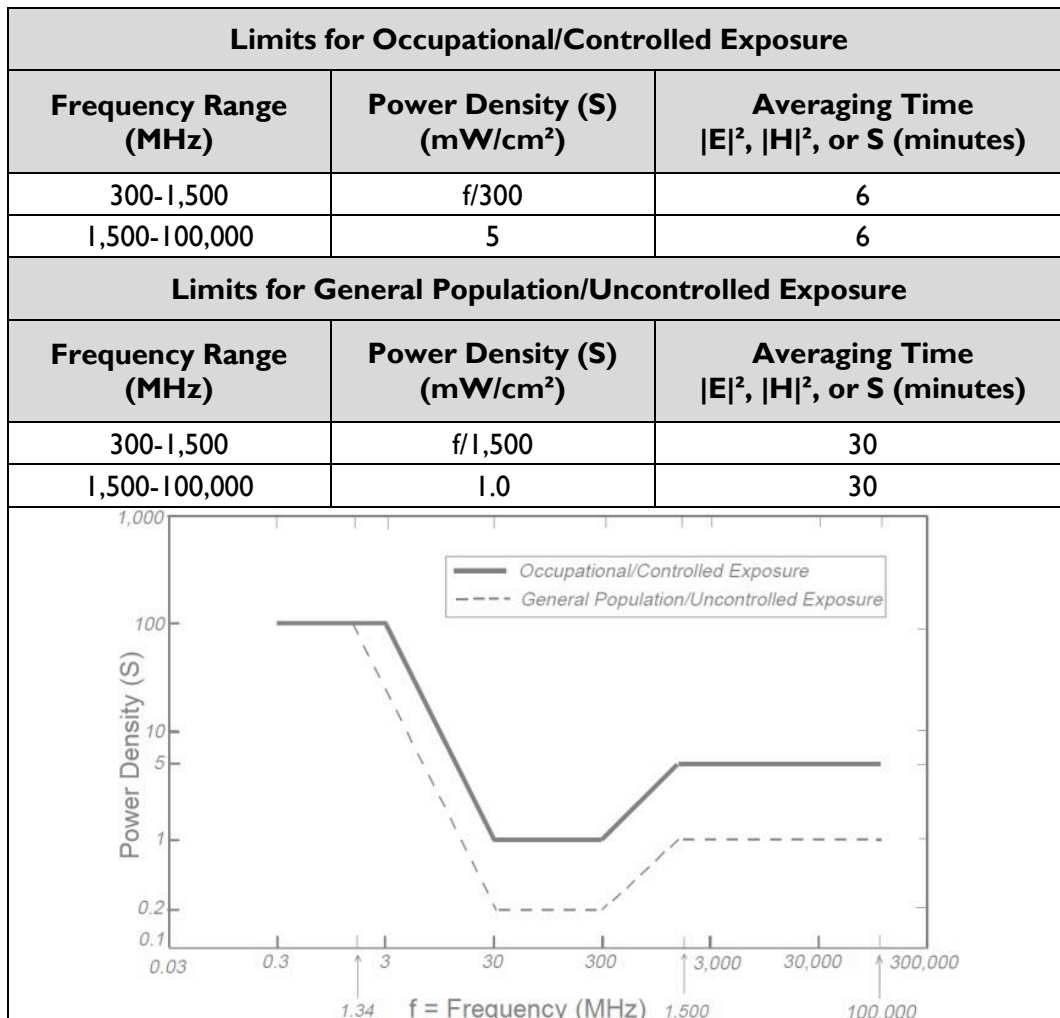



## 5.0 Safety Recommendations

### 5.1 OCCUPATIONAL SAFETY AND HEALTH ADMINISTRATION (OSHA) REQUIREMENTS

OSHA requires that those in the Occupational classification must complete training in RF Safety, RF Awareness, and Utilization of Personal Protective Equipment. OSHA also provides the following options for Hazard Prevention and Control:

Hazard Prevention	Control
<ul style="list-style-type: none"> <li>Utilization of good equipment</li> <li>Enact control of hazard areas</li> <li>Limit exposures</li> <li>Employ medical surveillance and accident response</li> </ul>	<ul style="list-style-type: none"> <li>Employ Lockout/Tag out</li> <li>Utilize personal alarms &amp; protective clothing</li> <li>Prevent access to hazardous locations</li> <li>Develop or operate an administrative control program</li> </ul>

### 5.2 RF SIGNAGE AND BARRIERS

All RF signs should be obeyed at all times.

<p><b>Guidelines</b></p>		<p><b>Blue Notice Sign</b></p>			
<p><b>Yellow Caution Sign</b></p>		<p><b>Orange Warning Sign</b></p>		<p><b>Red Danger Sign</b></p>	

If there are workers in an area with a sign that they do not understand, they can call the NOC Number at 877-611-5868 for guidance.

## **6.0 FCC Limits**

### **6.1 CONTRIBUTION TO CO-LOCATED AREAS**

Any wireless operator that contributes 5% or greater of the MPE limit in an area that is identified to be greater than 100% of the MPE limit is responsible for taking corrective actions to bring the site into compliance. All co-located sites should have a separate 5% modeling that shows only T-Mobile antennas transmitting. This separate modeling indicates T-Mobile's contribution in all areas that is recognized to be greater than 100% of MPE limits.

### **6.2 OCCUPATIONAL LIMITS**

Apply in situations in which persons are exposed as a consequence of their employment, provided those persons are fully aware of the potential for exposure and can exercise control over their exposure. Limits for occupational/controlled exposure also apply in situations when an individual is transient through a location where occupational/controlled limits apply provided he or she is made aware of the potential for exposure.

### **6.3 GENERAL POPULATION LIMITS**

Apply in situations in which the general public may be exposed, or in which persons that are exposed as a consequence of their employment may not be fully aware of the potential for exposure or cannot exercise control over their exposure. (those without significant and documented RF Safety & Awareness training)

### **6.4 CONTROLLED ENVIRONMENT**

Applies to environments that are restricted or "controlled" in order to prevent access from members of the General Population classification.

### **6.5 UNCONTROLLED ENVIRONMENT**

Applies to environments that are unrestricted or "uncontrolled" that allow access from members of the General Population classification.

### **6.6 GENERIC VALUES**

The use of "Unknown" for an operator means the information regarding the carrier, their FCC license and / or antenna information was not available. Generic values are used as an estimation for Effective Radiated Power (ERP) and antenna characteristics for unknown antennas.

# 7.0 MPE Analysis

MPE Analysis

Main Roof Level (27 feet AGL)

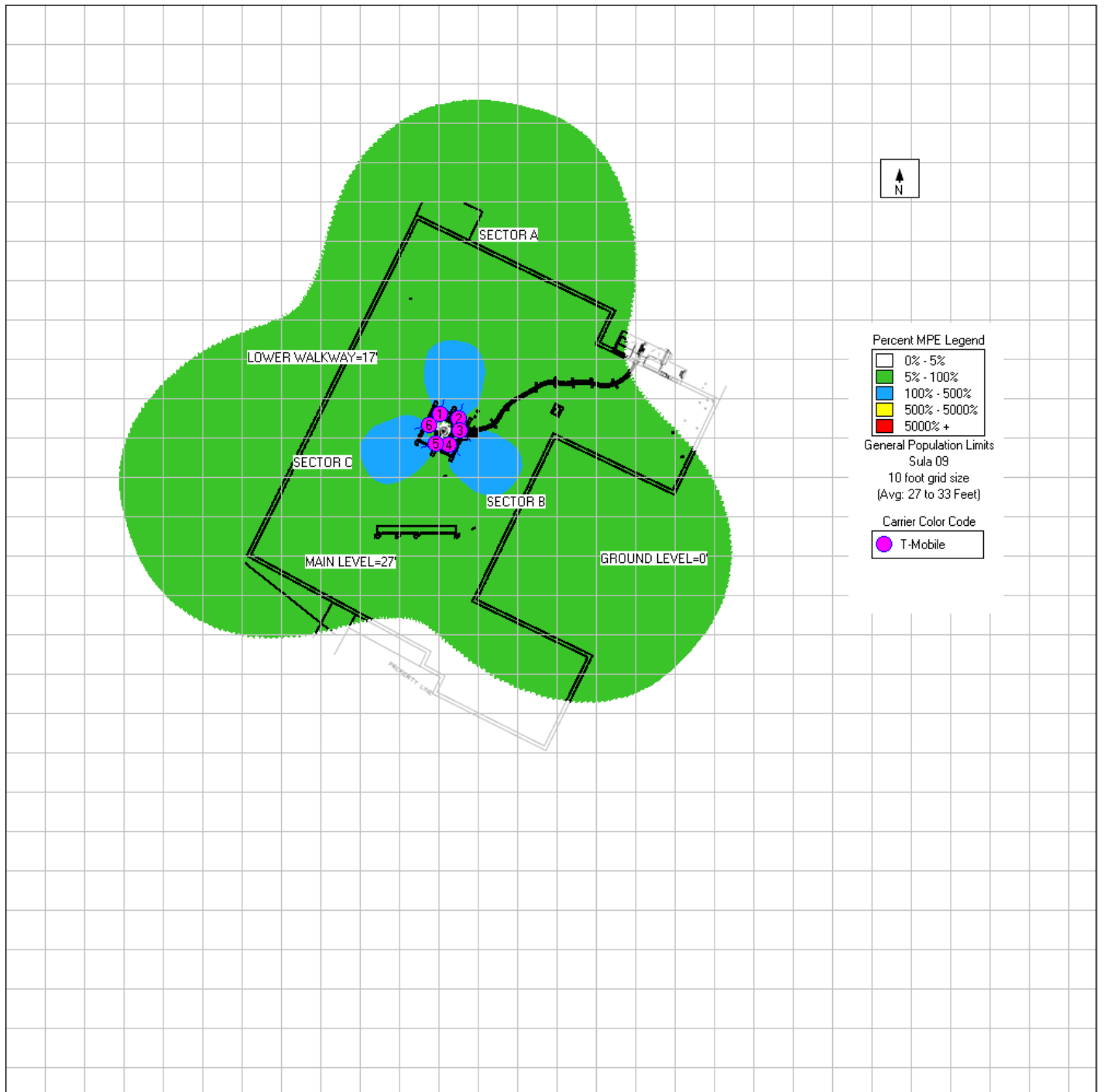

# MPE Analysis

# Lower Roof Level (17 feet AGL)

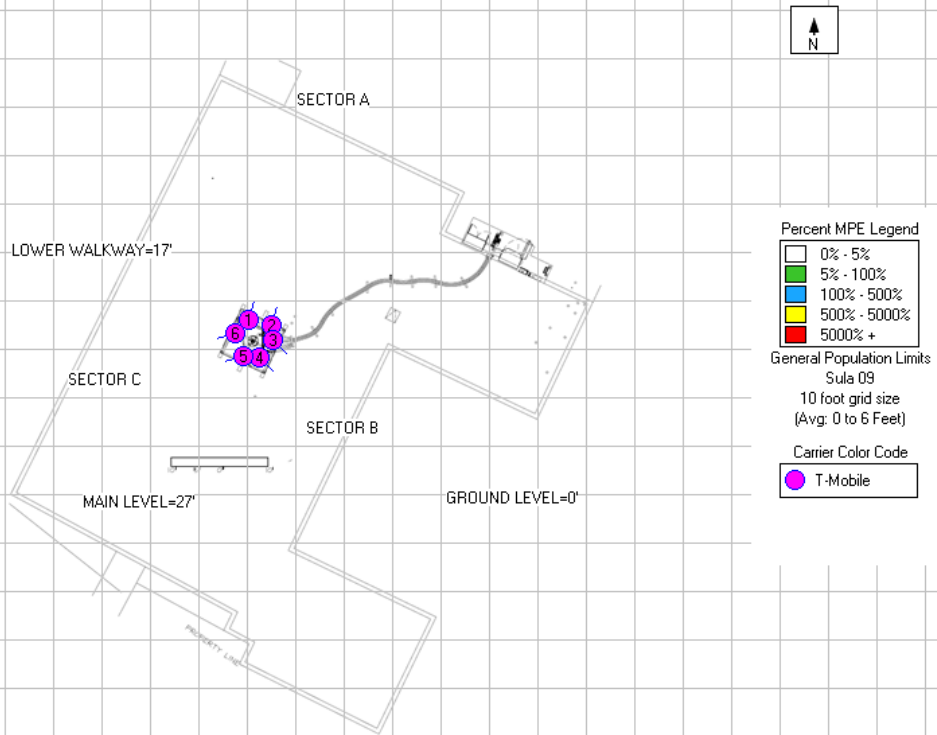

Exposures are into free space over lower walking/working surfaces.

lower walking/working surfaces.



# MPE Analysis

# Ground Level (0 feet AGL)

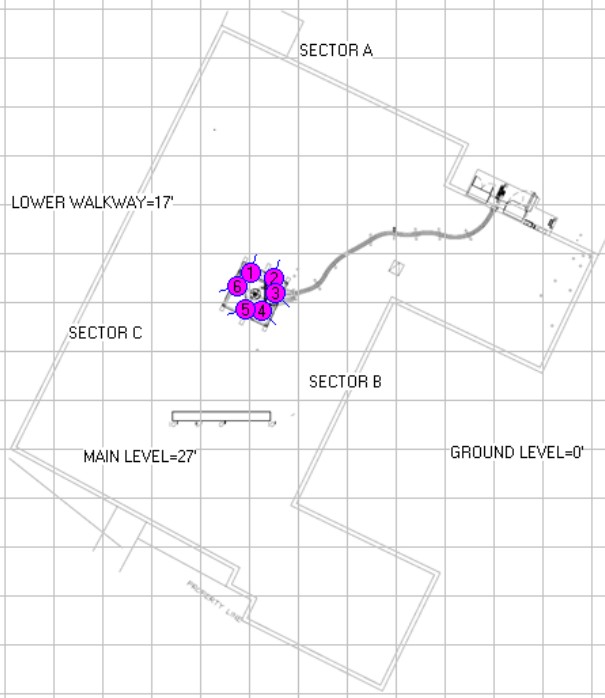

**Percent MPE Legend**

- 0% - 5%
- 5% - 100%
- 100% - 500%
- 500% - 5000%
- 5000% +

**General Population Limits**  
Sula 09  
10 foot grid size  
(Avg: 0 to 6 Feet)

**Carrier Color Code**  
T-Mobile

# 8.0 Mitigation Diagram

## Signage / Mitigation Diagram

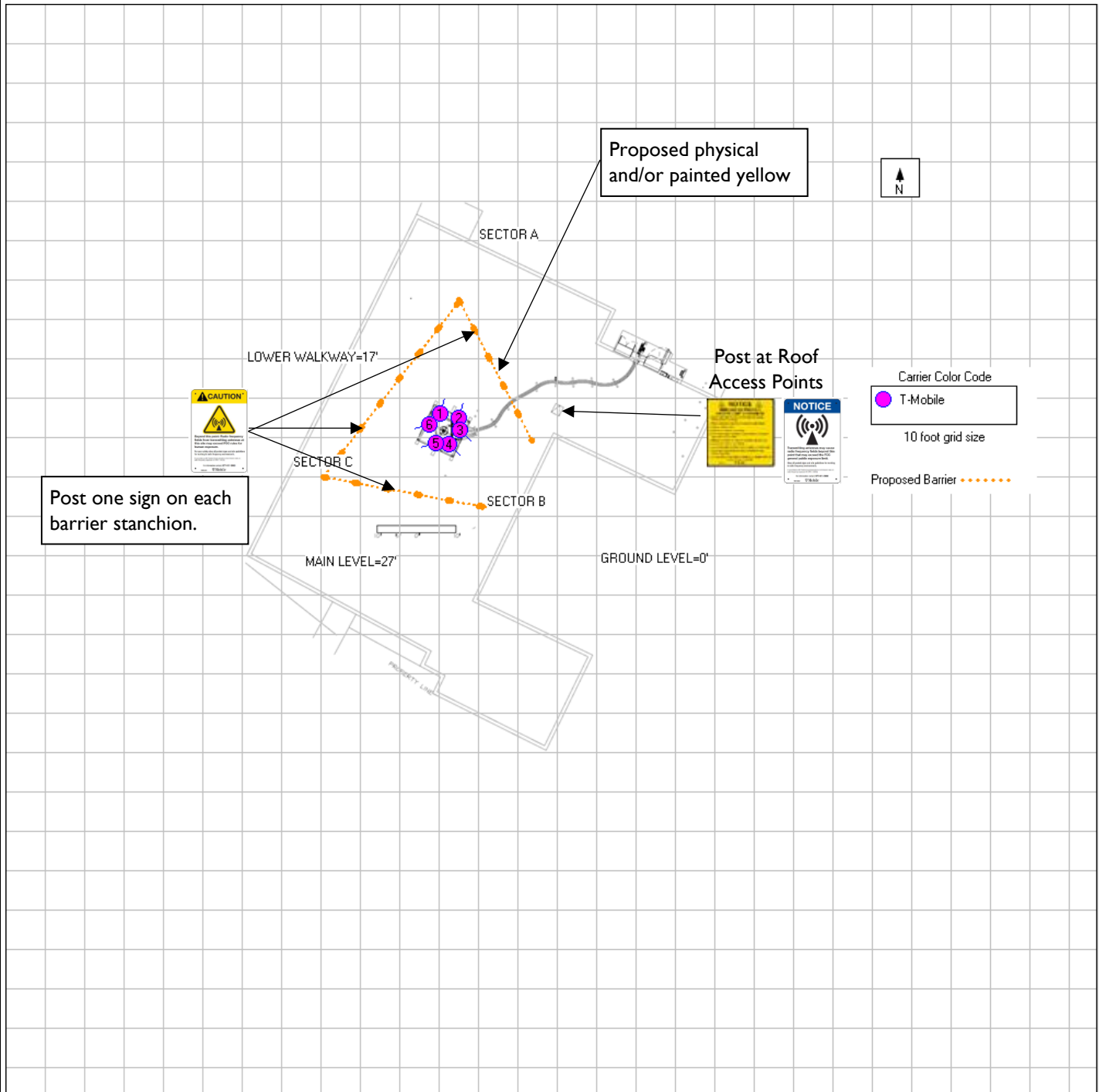

## 9.0 Summary

All calculations performed for this analysis yielded results that were above the allowable limits for exposure to RF Emissions. Based on predictive modeling, the worst-case emitted power density may exceed the FCC's general public limit within approximately 19 feet of T-Mobile's proposed antennas at the main roof level. Modeling also indicates that the worst-case emitted power density will not exceed the FCC's occupational limit at the main roof level. These predicted exposures are identified at the main roof level in the horizontal transmission path of the antennas.

There are no collocated carriers on the rooftop.

The anticipated maximum contribution from each sector of the proposed T-Mobile facility is 459.4700% of the allowable FCC established general public limit (91.8940% of the FCC occupational limit). This was determined through calculations along a radial from each sector taking full power values into account as well as actual vertical plane antenna gain values per the manufacturer-supplied specifications for gain. Based on worst-case predictive modeling, there are no areas at ground level related to the proposed antennas that exceed the FCC's occupational or general public exposure limits at this site. At ground level, the maximum power density generated by the antennas is approximately 1.8200% of the FCC's general public limit (0.3640% of the FCC's occupational limit).

A site is considered out of compliance with FCC regulations if there are areas that exceed the FCC exposure limits and there are no RF hazard mitigation measures in place. Any carrier which has an installation that contributes more than 5% of the applicable MPE must participate in mitigating these RF hazards. For this facility, the calculated values were above the allowable 100% threshold standard per the federal government.

Exposures are found when individuals are accessing or are elevated to the relevant walking/working surface on the horizontal plane. Antennas are constructed to concentrate energy toward the horizon, with as little energy as possible scattered toward the ground or the sky.

EBI's modeling indicates that there are areas in front of the T-Mobile antennas at the rooftop level that exceed the FCC standards for general public exposure. Based on worst-case predictive modeling, the worst-case emitted power density may exceed the FCC's general public limit within approximately 19 feet of T-Mobile's antennas at the main roof level. Modeling also indicates that the worst-case emitted power density will not exceed the FCC's occupational limit at T-Mobile's antennas at the main roof level. In order to alert any workers potentially accessing the site, a blue Notice sign and a yellow Guidelines sign are recommended at the first point(s) of access to the rooftop. To reduce the risk of exposure and/or injury, EBI recommends that access to the rooftop or areas associated with the active antenna installation be restricted and secured where possible. Barriers are recommended in front of the Sectors A, B, and C antennas at the main roof level. Yellow Caution signs should be placed on each approaching side of the barrier. Individuals should contact T-Mobile prior to accessing areas within the barrier footprint or any location around the antennas. Signage is recommended at the site as presented in the Mitigation Diagram. All workers and individuals, including arborists and landscapers, accessing the rooftop along with nearby elevated structures or trees within areas exceeding the general public MPE must be made aware of the presence and locations of antennas and their associated fields, where applicable.

## 10.0 Certification

## Preparer Certification

I, Drew Duncklee, state that:

- I am an employee of EnviroBusiness Inc. (d/b/a EBI Consulting), which provides RF-EME safety and compliance services to the wireless communications industry.
- I have successfully completed RF-EME safety training, and I am aware of the potential hazards from RF-EME and would be classified “occupational” under the FCC regulations.
- I am fully aware of and familiar with the Rules and Regulations of both the Federal Communications Commissions (FCC) and the Occupational Safety and Health Administration (OSHA) with regard to Human Exposure to Radio Frequency Radiation.
- I have been trained on RF-EME modeling using RoofMaster™ modeling software.
- I have reviewed the data provided by the client and incorporated it into this Site Compliance Report such that the information contained in this report is true and accurate to the best of my knowledge.



A rectangular box containing a handwritten signature in cursive script, which appears to read "D. Duncklee".



Reviewed and Approved by:



sealed 21dec2023

---

Michael McGuire  
Electrical Engineer  
[mike@h2dc.com](mailto:mike@h2dc.com)

Note that EBI's scope of work is limited to an evaluation of the Radio Frequency – Electromagnetic Energy (RF-EME) field generated by the antennas and broadcast equipment noted in this report. The engineering and design of the building and related structures, as well as the impact of the antennas and broadcast equipment on the structural integrity of the building, are specifically excluded from EBI's scope of work.



**COUNTY OF SAN MATEO - PLANNING AND BUILDING DEPARTMENT**

**ATTACHMENT E**

*Existing*



*Proposed*



view from 4th Avenue looking northwest at site  
**T-Mobile**  
SF03171A Atherton #5  
201 4th Avenue, Redwood City, CA  
Photosims Produced on 4-23-2019



*Existing*



Existing T-Mobile Installation

*Proposed*



Proposed T-Mobile Installation

view from 3rd Avenue looking southeast at site



*Existing*



Existing T-Mobile Installation

*Proposed*



Proposed T-Mobile Installation

view from 4th Avenue looking southwest at site



SF03171A Atherton #5  
201 4th Avenue, Redwood City, CA  
Photosims Produced on 4-23-2019





**COUNTY OF SAN MATEO - PLANNING AND BUILDING DEPARTMENT**

**ATTACHMENT F**

## Project Narrative for UP renewal PLN1999-00511

**Site Name:** SF03171A\_Anchor

**Project Address:** 201 4<sup>th</sup> Ave

**City/State/Zip:** Redwood City, CA 95408

**Representative:** Network Connex (Eric Hale on Behalf of T-Mobile)

**Date:** 01/12/2024

### Project Summary:

T-Mobile is proposing to upgrade an existing antenna array at the 32'1" rad center on an existing apartment rooftop owned by a private landlord. New overall height will be 36'1". Remove (3) existing antennas, (3) radios, and the "stealth" radome/cannister and replace with (6) new antennas, (6) radios, in a new 9' x 10' "stealth" frp box. Remove (1) ground cabinet and replace with (2) new smaller cabinets within the same footprint. There will be less than (4) cabinets on site.

There will be no trenching or lease area expansion.

- #1. This is a WTF as defined in the San Mateo County Zoning regulations.
- #2. This is a collocation facility as defined in Section 6511.C
- #3. This facility is in use under compliance of the conditions of approval under the original permit: PLN1999-00511
- #4. All application materials listed in the "Companion" Page are included with this submittal.

Thank you,



Eric Hale

Project Manager

[ehale@networkconnex.com](mailto:ehale@networkconnex.com)

416 Aviation Blvd., Suite B

Santa Rosa CA 95403

p: 916.805.6801

w: [www.networkconnex.com](http://www.networkconnex.com)



**COUNTY OF SAN MATEO - PLANNING AND BUILDING DEPARTMENT**

# **ATTACHMENT G**